

FINE AND RARE WINES
A GENTLEMAN'S COLLECTION
佳士得名釀

HONG KONG, 25-26 NOVEMBER 2016
香港 2016 年 11 月 25-26 日



CHRISTIE'S 佳士得

INTERNATIONAL WINE DEPARTMENT & AUCTION CALENDAR

INTERNATIONAL

HEAD OF DEPARTMENT

David Elswood
Tel: +44 (0)20 7752 3366

HEAD OF DEPARTMENT

ASIA

Simon Tam
Tel: +852 2978 6765

LONDON

Chris Munro
Tel: +44 (0)20 7752 3140

NORTH AMERICA

Per Holmberg
Tel: +1 212 484 4841

SENIOR CONSULTANTS

Michael Broadbent M.W.
Anthony Hanson M.W.
Tel: +44 (0)20 7752 3314

WORLDWIDE

AMSTERDAM

Edwin Vos
Tel: +31 (0)20 575 5208

BELGIUM

Fiona Morrison, M.W.
Tel: +32 (0)55 31 17 59

BORDEAUX

Bill Blatch
Tel: +33 (0)777 965 565

BEIJING

Austin Zhang
Tel: +86 10 8572 7927

GENEVA

Agathe de Saint Céran
Tel: +41(0) 22 31 917 60

HONG KONG

Simon Tam
Tim Triptree
Fai Lo
Tiffany Po
Tel: +852 2978 6761

LONDON

Carolyn Holmes
Peter Mansell
Charles Foley
Duncan McEuen (Consultant)
Tel: +44 (0)20 7752 3302

LOS ANGELES

Scott Torrence
Tel: +1 310 385 2625

NEW YORK

Per Holmberg
Richard Young
Noah May
Layla Khabiri
Scott Torrence
Tel: +1 212 636 2270

PARIS

Edwin Vos
Agathe de Saint Céran
Clément Huvet
Tel: + 33(0) 1 40 76 83 88

BUSINESS MANAGERS

FRANCE

Sarah de Maistre
Tel: +33 (0)1 40 76 83 56

HONG KONG

Cindy Tse
Tel: +852 2978 6759

LONDON

Laure Camboulives
Tel: +44 (0)20 7752 3252

NEW YORK

Devon Elovitz
(Business Coordinator)
Tel: +1 212 641 5776

10/08/16

AUCTION CALENDAR 2016

To include your property in these sales please consign ten weeks before the sale date. Contact the specialists or representative office for further information.

10 NOVEMBER

FINE AND RARE WINES
LONDON, KING STREET

13 NOVEMBER

FINE WINES
GENEVA

17 NOVEMBER -

1 DECEMBER
WINE ONLINE/LDN

20 NOVEMBER

156ÈME VENTE DES VINS
DES HOSPICES DE BEAUNE
BEAUNE

25-26 NOVEMBER

FINE AND RARE WINES:
A GENTLEMAN'S
COLLECTION
HONG KONG

26 NOVEMBER

FINE AND RARE WINES
FEATURING EXCEPTIONAL
PRIVATE COLLECTIONS
HONG KONG

8 DECEMBER

FINE AND RARE WINES
LONDON, KING STREET

9 DECEMBER

FINE AND RARE WINES
NEW YORK

SERVICES · 服務

WRITTEN AND TELEPHONE BIDS

書面和電話競投

Tel 電話: +852 2978 9910

Email 電郵: bidsasia@christies.com

PADDLE REGISTRATION & CHRISTIE'S LIVE

競投牌登記和佳士得實時競投服務

Tel 電話: +852 2760 1766

Email 電郵: registrationasia@christies.com

CATALOGUES ONLINE 網上拍賣目錄

Lotfinder®

Internet 網站: www.christies.com

CLIENT SERVICES 客戶服務

Tel 電話: +852 2760 1766

Email 電郵: infoasia@christies.com

POST-SALE SERVICES 售後服務

Tel 電話: +852 2760 1766

Fax 傳真: +852 2973 0111

Email 電郵: postsaleasia@christies.com

AUCTION RESULTS 拍賣結果

HK 香港: +852 2760 1766

UK 英國: +44 (0)20 7627 2707

US 美國: +1 212 703 8080

Internet 網站: www.christies.com

We have re-located our wine storage facility to Crown Wine Cellars, 2/F Crown Data Centre 1, 6 Kin Fung Circuit, Tuen Mun, N.T. Wines purchased in this sale, will be available for collection and/or delivery from Crown Wine Cellars. For further details, please contact Post-Sale Services Department on +852 2760 1766.

本公司已將名酒儲存庫搬遷至 Crown Wine Cellars (新界屯門建豐街6號嘉柏中心1期2樓)。此次名酒拍賣的名酒可於 Crown Wine Cellars 提取和/或交付。請聯繫佳士得售後服務部 (電話+852 2760 1766) 查詢詳情。

Scan to view auction details

掃描以瀏覽拍賣詳情



Christie's Hong Kong Autumn Auctions Microsite
佳士得香港秋拍週網站

CHRISTIE'S LIVE
Bid live in Christie's salerooms worldwide

christies.com

FINE AND RARE WINES: A GENTLEMAN'S COLLECTION

佳士得名釀

FRIDAY-SATURDAY 25-26 NOVEMBER 2016

2016年11月25-26日(星期五至六)

AUCTION · 拍賣

Friday 25 November · 11月25日(星期五)

5.00pm (Lots 5001-5233), 下午5.00 (拍賣品編號 5001-5233)

Saturday 26 November · 11月26日(星期六)

10.30am (Lots 5234-5463), 上午10.30 (拍賣品編號 5234-5463)

Location: Grand Hall, Hong Kong Convention and Exhibition Centre,
No.1 Expo Drive, Wanchai, Hong Kong

地點: 香港灣仔博覽道1號香港會議展覽中心大會堂

Tel 電話: +852 2760 1766 · Fax 傳真: +852 2760 1767

AUCTION CODE AND NUMBER · 拍賣名稱及編號

In sending Written and Telephone bids or making enquiries, this sale should be referred to as **GENTLEMAN-12576**

在遞交書面和電話競投表格或查詢拍賣詳情時, 請註明拍賣名稱及編號為 **GENTLEMAN-12576**。

CONDITIONS OF SALE · BUYING AT CHRISTIE'S

業務規定 · 買家須知

This auction is subject to Important Notices and Explanation of Cataloguing Practice, Conditions of Sale · Buying at Christie's and reserves of the lots.

此次拍賣受限於重要通知及目錄編列方法之說明、業務規定 · 買方須知及拍品底價。

ENQUIRIES · 查詢

Jennifer Lo, Sale Co-ordinator 盧正琛

Tel 電話: +852 2978 6761

EMAIL · 電郵

For general enquiries about this auction, emails should be addressed to the Sale Co-ordinator(s) at wineauction@christies.com

如對此拍賣有任何查詢, 可與佳士得拍賣統籌聯絡。

電郵地址: wineauction@christies.com

AUCTIONEERS · 拍賣官

David Elswood

Simon Tam

Austin Zhang

CHRISTIE'S 佳士得

INTERNATIONAL WINE DEPARTMENT

SENIOR INTERNATIONAL TEAM



David Elswood



Per Holmberg



Chris Munro



Edwin Vos

ASIA TEAM



Simon Tam



Tim Triptree



Fai Lo



Tiffany Po



Austin Zhang



Cindy Tse

INTERNATIONAL CONSULTANTS



Michael Broadbent
M.W.



Anthony Hanson
M.W.



Bill Blatch

FINE AND RARE WINES:

A GENTLEMAN'S COLLECTION

佳士得名釀

FRIDAY 25 NOVEMBER 2016

5.00pm

Lots 5001-5233

SATURDAY 26 NOVEMBER 2016

10.30am

Lots 5234-5463

Sale 12576

11月25日(星期五)

下午五時正

(拍品 5001 至 5233)

11月26日(星期六)

上午十時三十分

(拍品 5234 至 5463)

編號 12576

Grand Hall, Hong Kong Convention and Exhibition Centre,

No.1 Expo Drive, Wanchai, Hong Kong

香港灣仔博覽道1號香港會議展覽中心大會堂

Please note that parcel bidding will be offered throughout Sale 12576.

請注意，本場拍賣(編號12576)部份拍品將以組合形式推出。成功投得每個組合第一款拍品的買家，可選擇以同一價格購買餘下所有或部份拍品。

Our Asian-based consignor discovered wines in the early 1990's. He recalls his first taste of wines fondly; "this 1982 Margaux is very delicious". He then embarked on a journey to understand, appreciate and collect the finest wines the world has to offer.

The many vintages in this exquisite single-owner collection are reaching the prime of their maturity and will provide immense enjoyment to those lucky buyers. This is a perfect collection for drinking and sharing with friends and family. Indeed it is our consignor's wish to share these wines that are at their peak drinking windows and will be extraordinarily complex, refined and provide immense drinking pleasure.

All the wines were stored in purpose build wine storage under temperature and humidity control in the consignor's properties prior to removal specifically for this sale.

The depth and excellence of the vintages and the breadth of selection of many of the greatest wines of the world truly reflects our consignor's quality focused philosophy.

Simon Tam

Head of Wine, Asia

我們這位亞洲藏家早在90年代初對酒產生濃厚興趣。他依舊記得記憶裡的第一口葡萄酒：1982年瑪歌非常美味可口。隨即他開啟了一段探索、欣賞和收藏葡萄酒的旅程。

這批私人收藏中的許多年份都已經到達適飲期，將為幸運的買家提供無盡的樂群。這批收藏是與親朋好友共飲的最好選擇。這也是這位藏家的心願，在酒醉美好的時候與大家共同體驗複雜、精巧、極致的飲酒樂趣。

所有的葡萄酒均存放於藏家專門建立的控溫控濕酒窖，直到本次拍賣前才運輸到港。

這些卓絕的年份和精心的選擇，反映了藏家注重品質的收藏哲學。

譚業明

亞洲區名酒部主管

FRIDAY 25 NOVEMBER · 5.00PM
Lots 5001-5233

FINE & RARE WINES: A GENTLEMAN'S COLLECTION
佳士得名釀

Billecart-Salmon, Brut 1961

*Champagne
Very slightly stained label*

5001 1 magnum *per lot* HK\$5,500-9,500

**Bollinger La Grande Année Brut James Bond 007
Edition 1999**

*Aÿ
In original wooden boxes*

5002 2 magnums *per lot* HK\$5,000-8,500

Amour de Deutz 2000

*Aÿ
In original gift box*

5003 1 methuselah *per lot* HK\$5,000-8,500

Krug Collection 1949

*Reims
Very slightly stained and slightly damaged label. US
import back label. Good level*

5004 1 bottle *per lot* HK\$40,000-65,000

Krug Collection 1979

*Reims
In individual original wooden cases*

5005 3 magnums *per lot* HK\$55,000-90,000

Krug Collection 1981

*Reims
In individual original wooden cases*

5006 5 magnums *per lot* HK\$45,000-75,000

Krug Collection 1985

*Reims
Six in individual original wooden cases. Two slightly
corroded vintage neck shields*

5007 8 bottles *per lot* HK\$38,000-65,000

Krug Clos d'Ambonnay 1995

*Reims
In individual original gift boxes. One very slightly
damaged label*

5008 2 bottles *per lot* HK\$26,000-45,000

Krug Clos d'Ambonnay 1995

*Reims
In individual original gift boxes*

5009 5 bottles *per lot* HK\$65,000-110,000



Krug Clos d'Ambonnay 1996

Reims

Lots 5010-5011: Six in original wooden case without lid

5010 8 bottles per lot HK\$110,000-180,000
 5011 8 "

Krug Clos du Mesnil 1979

Reims

Two stained and slightly damaged foils. One stained back label. One US import slip label

5012 3 bottles per lot HK\$65,000-110,000

Krug Clos du Mesnil 1988

Reims

US import slip labels

5013 2 magnums per lot HK\$38,000-65,000

Krug Clos du Mesnil 1988

Reims

5014 4 bottles per lot HK\$38,000-65,000

Lots 5012-5016

Spicy Crayfish and Krug Clos du Mesnil

Spicy Crayfish is the most popular summer dish in China, loved for its unique piquant flavour, eye-catching fiery red appearance, silken flesh and the tingling sensation it leaves on the tongue. Spicy Crayfish stall nearby the main entrance of Hunan Television Headquarters probably serves the most authentic version of the dish, and is much visited by stars and celebrities after their filming at television station. The overnight street market on *Gui Street*, Beijing, is another mecca for Spicy Crayfish lovers. All over the market, there are restaurants serving the dish and tonnes of crayfish are sold on each summer night. While spicy dishes are generally difficult to pair with wine, they are excellent with champagne. The fine carbonated bubbles of champagne offer a fascinating match to the tingling, numbing sensation on the palate brought by the hot dish. Krug Clos de Mesnil Blanc de Blanc Brut Champagne is created with Grand Cru Chardonnay from Le Mesnil-sur-Oger. The vibrant, well-honed acidity can set off spicy flavours. Offering lots of minerality, its subtle and layered notes of caramel and biscuits support perfectly the delicate savour of crayfish.

Autumn 2015. Austin Zhang

Krug Clos du Mesnil 1995

Reims

One slightly damaged label and back label

5015 6 bottles per lot HK\$35,000-55,000

Krug Clos du Mesnil 1996

Reims

One in original wooden case. One very slightly damaged label. US import back labels

5016 2 magnums per lot HK\$30,000-50,000

Krug Brut 1979

Reims

One very slightly damaged label. US import slip labels

5017 2 bottles per lot HK\$11,000-18,000

Krug Brut 1981

Reims

In original carton. Very slightly damaged labels. US import slip labels

5018 11 bottles per lot HK\$32,000-55,000

Krug Brut 1988

Reims

Six in original carton. Four very slightly damaged vintage neck labels. Ten very slightly damaged labels. Seven US import slip labels

5019 14 bottles per lot HK\$45,000-75,000

Mixed Krug Clos du Mesnil 1996 & 1998**1996 Krug Clos du Mesnil***Six in individual gift boxes*

(9)

1998 Krug Clos du Mesnil

(1)

5020 Above 10 bottles per lot HK\$75,000-130,000

Mixed Krug Brut 1988 & 1990**1988 Krug Brut** (6)*In slightly damaged original carton. Very slightly damaged labels. US slip labels***1990 Krug Brut** (6)*Very slightly damaged labels. US slip labels*5021 Above 12 bottles *per lot* HK\$35,000-55,000**Mixed Formats of Krug 1982 & 1985****1982 Krug Brut** magnum (1)**1982 Krug Brut** (4)*Two very slightly damaged and two damaged labels. US import slip labels***1985 Krug Brut** magnum (1)*Stained and slightly damaged front and back label*5022 Above 2 magnums and 4 bottles *per lot* HK\$26,000-45,000**Mixed Krug 1995 & 1996****1995 Krug Clos d'Ambonnay** (1)*In original gift box***1995 Krug Brut** (6)*Three in original gift boxes. Three slightly damaged labels***1996 Krug Brut** (4)*One very slightly damaged label*5023 Above 11 bottles *per lot* HK\$32,000-48,000**Louis Roederer, Cristal 1966***Reims**Stained and very slightly damaged labels. US import slip labels. Good levels*5024 2 magnums *per lot* HK\$35,000-60,000**Louis Roederer, Cristal 1979***Reims**Corroded foils. Signs of old seepage. Slightly stained labels, one slightly damaged. Levels one 0.5cm below base of foil*5025 2 bottles *per lot* HK\$14,000-24,000**Vertical of Louis Roederer Cristal****1985 Louis Roederer, Cristal** (1)*Very slightly damaged foil. Slightly damaged label. US import slip label***1986 Louis Roederer, Cristal** (1)*Slightly damaged foil. Slightly stained and slightly damaged label. US import slip label***1988 Louis Roederer, Cristal** (1)*Slightly damaged foil. Slightly damaged label. US import slip label***1989 Louis Roederer, Cristal** (1)**1990 Louis Roederer, Cristal** (1)*Sign of seepage. US import slip label***1996 Louis Roederer, Cristal** (1)*Sign of seepage. Slightly damaged label***1999 Louis Roederer, Cristal** (1)*Slightly damaged neck and front label*5026 Above 7 bottles *per lot* HK\$18,000-32,000**Dom Pérignon Oenothèque 1959***Epernay**Slightly damaged foil*5027 1 bottle *per lot* HK\$13,000-22,000**Dom Pérignon Oenothèque 1969***Epernay**Six in original wooden cases, one in individual gift box. Two UK import back labels*5028 8 bottles *per lot* HK\$100,000-160,000**Dom Pérignon Oenothèque 1973***Epernay**Five in individual original wooden cases*5029 6 bottles *per lot* HK\$50,000-90,000**Dom Pérignon Oenothèque 1975***Epernay**In individual original gift boxes*5030 4 bottles *per lot* HK\$38,000-60,000

Dom Pérignon Oenothèque 1975*Epernay**Six in individual wooden cases. One damaged back label*5031 7 bottles *per lot* HK\$65,000-100,000**Dom Pérignon Oenothèque 1976***Epernay**In individual original wooden cases*5032 8 bottles *per lot* HK\$55,000-95,000**Dom Pérignon Oenothèque 1983***Epernay**In individual original wooden cases*5033 5 bottles *per lot* HK\$20,000-32,000**Dom Pérignon Oenothèque 1992***Epernay**In individual original gift boxes*5034 5 bottles *per lot* HK\$10,000-16,000**Dom Pérignon Oenothèque 1993***Epernay**In individual original gift boxes*5035 8 bottles *per lot* HK\$16,000-26,000**Dom Pérignon Oenothèque Rosé 1990***Epernay**In individual original gift boxes*5036 10 bottles *per lot* HK\$35,000-60,000**Dom Pérignon 1966***Epernay**Italian import slip label. Slightly damaged label. Level 2cms*5037 1 magnum *per lot* HK\$11,000-18,000**Dom Pérignon 1969***Epernay**Two slightly damaged labels. Two US import slip labels. Levels 2.5cms*5038 2 bottles *per lot* HK\$9,000-15,000**Dom Pérignon 1996***Epernay**Very slightly damaged foils. Very slightly damaged back labels*5039 12 bottles *per lot* HK\$22,000-35,000**Dom Pérignon 1996***Epernay**Three in original gift boxes. Very slightly damaged foils. Very slightly damaged back labels*5040 12 bottles *per lot* HK\$22,000-35,000**Mixed Dom Pérignon 1955 & 1962****1955 Dom Pérignon***Damaged label. US import slip label. Level 5cms*

(1)

1962 Dom Pérignon*Slightly damaged label. Italian slip label. Level 3cms*

(1)

5041 Above 2 bottles *per lot* HK\$14,000-24,000**Mixed Dom Pérignon Oenothèque 1962 & 1971****1962 Dom Pérignon Oenothèque***In original wooden case*

(1)

1971 Dom Pérignon Oenothèque*In original wooden case*

(1)

5042 Above 2 bottles *per lot* HK\$20,000-32,000**Mixed Formats of Dom Pérignon 1964****1964 Dom Pérignon**

magnum (1)

*Corroded foil. Stained and slightly damaged label. Level 5.5cms***1964 Dom Pérignon**

(2)

*Slightly damaged labels. US import back labels, one stated recently disgorged. Levels one high fill and one 3cms*5043 Above 1 magnum and 2 bottles *per lot* HK\$20,000-32,000

Mixed Formats of Dom Pérignon 1971

1971 Dom Pérignon magnum (1)
Slightly damaged foil. Slightly damaged label. Level 3cms

1971 Dom Pérignon (2)
Slightly damaged labels. Levels 2.5cms

5044 Above 1 magnum and 2 bottles
per lot HK\$18,000-30,000

Mixed Dom Pérignon & Dom Pérignon Rosé 1996

1996 Dom Pérignon (7)
In individual original gift boxes

1996 Dom Pérignon Rosé (3)
Two in individual original gift boxes. One slightly damaged foil

5045 Above 10 bottles
per lot HK\$20,000-35,000

Philipponnat Clos des Goisses 1989

*Mareuil-sur-Aÿ
Slightly stained labels. Slightly damaged back labels.
US import slip labels. Levels two 1.5cms, one 2cms and one 3cms*

5046 4 magnums
per lot HK\$16,000-26,000

Philipponnat Clos des Goisses 1996

*Mareuil-sur-Aÿ
Levels two 1.5cms, seven 2cms and three 2.5cms*

5047 12 bottles
per lot HK\$22,000-35,000

Philipponnat Clos des Goisses 1996

*Mareuil-sur-Aÿ
Three very slightly damaged labels. Levels three 1.5cms, nine 2cms, six 2.5cms and one 3cms*

5048 19 bottles
per lot HK\$35,000-55,000

Piper-Heidsieck Brut Cuvée Rare Millesime 1979

*Reims
In individual original gift boxes*

5049 15 bottles
per lot HK\$55,000-95,000

Salon Le Mesnil 1990

*Le Mesnil-sur-Oger
One very slightly damaged label*

5050 5 bottles
per lot HK\$16,000-26,000

Salon Le Mesnil 1996

*Le Mesnil-sur-Oger
In individual original wooden cases. Two very slightly damaged labels*

5051 10 bottles
per lot HK\$30,000-50,000

Château Lafite-Rothschild 1949

*Paulliac, 1er cru classé
Stained and very slightly damaged labels. Levels one base of neck and one top-shoulder*

5052 2 bottles
per lot HK\$18,000-30,000



Lot 5051

Château Lafite-Rothschild 1953*Pauillac, 1er cru classé**One removed capsule to reveal the year of recorking. One damaged recent capsule. Three very slightly damaged original capsules. Five slightly stained and slightly damaged labels. One badly damaged label. US import slip labels. Two recorked in 1996 and one in 2001. Levels three into neck and three top-shoulder*5053 6 bottles *per lot* HK\$80,000-150,000**Château Lafite-Rothschild 1959***Pauillac, 1er cru classé**Four slightly corroded, one missing, two damaged capsules without bottom part and two cut capsules. Stained and slightly damaged labels. Five US import slip labels. Levels: one base of neck, two top-shoulder, one upper-shoulder, two mid-upper shoulder and one mid-shoulder*5054 7 bottles *per lot* HK\$95,000-180,000**Château Lafite-Rothschild 1982***Pauillac, 1er cru classé**Slightly damaged capsules. Very slightly stained labels. Levels one base of neck and one top-shoulder*5055 2 bottles *per lot* HK\$30,000-50,000**Château Lafite-Rothschild 1986***Pauillac, 1er cru classé**Slightly faded capsules, one cut to reveal branded cork. Slightly stained labels, one damaged. Levels into neck*5056 2 magnums *per lot* HK\$24,000-42,000**Château Lafite-Rothschild 1986***Pauillac, 1er cru classé**Slightly damaged capsules. Slightly stained labels. One slightly damaged label. Levels base of neck*5057 7 bottles *per lot* HK\$45,000-70,000**Château Lafite-Rothschild 1998***Pauillac, 1er cru classé**One sign of old seepage. One stained and two slightly damaged labels. Levels into neck*5058 13 bottles *per lot* HK\$55,000-95,000**Château Lafite-Rothschild 2000***Pauillac, 1er cru classé**One sign of old seepage. Slightly stained labels, four very slightly damaged. One Chinese import back label*5059 6 bottles *per lot* HK\$50,000-85,000**Château Lafite-Rothschild 2003***Pauillac, 1er cru classé*5060 1 double-magnum *per lot* HK\$22,000-38,000**Mixed Château Lafite-Rothschild 1995 & 1997 in Magnums****1995 Château Lafite-Rothschild** magnums (4)*Two very slightly protruding corks. Levels into neck***1997 Château Lafite-Rothschild** magnum (1)*Level into neck*5061 Above 5 magnums *per lot* HK\$40,000-65,000**Mixed Château Lafite-Rothschild 1995 & 1996****1995 Château Lafite-Rothschild** (6)*Three very slightly damaged labels. Three US import slip labels. Levels into neck***1996 Château Lafite-Rothschild** (4)*Two stained and slightly damaged labels. Levels into neck*5062 Above 10 bottles *per lot* HK\$50,000-80,000**Mixed Château Lafite-Rothschild 1989, 1999 & 2003****1989 Château Lafite-Rothschild** (2)*One Japanese import back label. Very slightly stained labels. Levels into neck***1999 Château Lafite-Rothschild** (3)*Stained and slightly damaged labels. Levels into neck***2003 Château Lafite-Rothschild** (2)5063 Above 7 bottles *per lot* HK\$32,000-55,000**Château Latour 1961***Pauillac, 1er cru classé**Slightly damaged capsule. Stained label. Level top-shoulder*5064 1 bottle *per lot* HK\$18,000-30,000

Château Latour 1982*Pauillac, 1er cru classé**Two slightly stained and two slightly damaged labels.**Two integrated US import labels. Levels base of neck*5065 6 bottles *per lot* HK\$60,000-100,000**Château Latour 1982***Pauillac, 1er cru classé**Two very slightly corroded and two very slightly**damaged capsules. Eight very slightly depressed corks.**Two very slightly stained and five very slightly damaged**integrated US import labels. Levels one base of neck,**six top-shoulder, two upper-shoulder and one mid-**shoulder*5066 10 half-bottles *per lot* HK\$48,000-80,000**Château Latour 1986***Pauillac, 1er cru classé**Two integrated US import labels. Levels six into neck**and three base of neck*5067 9 bottles *per lot* HK\$24,000-40,000**Château Latour 1995***Pauillac, 1er cru classé**Released from Château in 2013. Five slightly stained**labels. Levels into neck*5068 10 bottles *per lot* HK\$35,000-55,000**Château Latour 1996***Pauillac, 1er cru classé**Levels into neck*5069 12 bottles *per lot* HK\$55,000-90,000**Château Latour 2000***Pauillac, 1er cru classé**Five US import slip labels. Slightly stained and very**slightly damaged labels*5070 8 bottles *per lot* HK\$48,000-80,000**Mixed Formats of Château Latour 1952****1952 Château Latour** magnum (1)*Slightly damaged original capsule. Stained and slightly**damaged label. Level upper-shoulder***1952 Château Latour** (2)*Corroded original capsules. Damaged and badly**stained labels. Levels mid-shoulder*

5071 Above 1 magnum and 2 bottles

per lot HK\$17,000-35,000**Mixed Formats of Château Latour 1959****1959 Château Latour** (3)*Corroded and slightly damaged capsules. Stained and**slightly damaged labels, one slightly faded. Levels one**upper-shoulder and two mid-upper shoulder***1959 Château Latour** half-bottles (2)*Very slightly damaged capsules. Very slightly stained**labels. Levels one upper-shoulder and one mid-upper**shoulder*

5072 Above 3 bottles and 2 half-bottles

per lot HK\$40,000-80,000**Mixed Château Latour 1986 & 1995****1986 Château Latour** (7)*One damaged capsule. Five integrated US import**labels. Levels two into neck and five base of neck***1995 Château Latour** (5)*Four US import slip labels. One released from Château**in 2013. Four slightly stained and two very slightly**damaged labels. Levels into neck*5073 Above 12 bottles *per lot* HK\$38,000-60,000**Mixed Château Latour 1990, 1995 & 2003****1990 Château Latour** (1)*Very slightly stained label. Level base of neck***1995 Château Latour** (1)*Very slightly stained label. US import slip label. Level**into neck***2003 Château Latour** (5)*Two slightly damaged and three damaged labels. One**US import slip label*5074 Above 7 bottles *per lot* HK\$35,000-60,000

Château Mouton Rothschild 1945*Pauillac, 1er cru classé**Four cut capsules to reveal fully branded corks, all corroded and damaged capsules. Four bottles recorked in 1977. One depressed cork. Stained labels, three very slightly damaged. Levels: one base of neck, two top-shoulder, two upper-shoulder*5075 5 bottles *per lot* HK\$350,000-650,000**Château Mouton Rothschild 1953***Pauillac, 1er cru classé**Two corroded and one slightly damaged capsules. Stained and slightly damaged labels. Levels two top-shoulder and two mid-shoulder*5076 4 bottles *per lot* HK\$35,000-80,000**Château Mouton Rothschild 1959***Pauillac, 1er cru classé**One slightly corroded and cut capsule. Slightly stained and damaged label. US import slip label. Level one upper-shoulder and one mid-upper shoulder*5077 2 bottles *per lot* HK\$28,000-45,000**Château Mouton Rothschild 1982***Pauillac, 1er cru classé**Seven damaged capsules. One integrated US import label. Five slightly stained and two slightly damaged labels. Levels two into neck and twelve base of neck*5078 14 bottles *per lot* HK\$100,000-170,000**Château Mouton Rothschild 1986***Pauillac, 1er cru classé**Two very slightly damaged capsules. Stained and four damaged labels. Levels six top-shoulder and three mid-upper shoulder*5079 9 half-bottles *per lot* HK\$22,000-38,000**Château Mouton Rothschild 1995***Pauillac, 1er cru classé**Four slightly stained and one very slightly damaged labels. One Japanese import slip label. Levels into neck*5080 6 bottles *per lot* HK\$18,000-30,000**Château Mouton Rothschild 1998***Pauillac, 1er cru classé**Two signs of old seepage. One slightly protruding cork. Four very slightly stained and one slightly wrinkled labels. One slightly wrinkled back label*5081 7 bottles *per lot* HK\$20,000-32,000**Château Mouton Rothschild 2000***Pauillac, 1er cru classé*5082 11 bottles *per lot* HK\$110,000-180,000**Château Mouton Rothschild 2009***Pauillac, 1er cru classé**Very slightly damaged label. Level into neck*5083 1 impérial *per lot* HK\$32,000-55,000**Mixed Château Mouton Rothschild 1952, 1955 & 1959****1952 Château Mouton Rothschild** (1)
*Damaged capsule. Stained and damaged label. Level mid-low shoulder***1955 Château Mouton Rothschild** (1)
*Damaged capsule. Protruding cork. Stained and damaged label. Level very top-shoulder***1959 Château Mouton Rothschild** (1)
*Slightly stained label. Level mid-upper shoulder*5084 Above 3 bottles *per lot* HK\$30,000-50,000**Mixed 1960's & 1970's Château Mouton Rothschild****1962 Château Mouton Rothschild** (1)
*Stained label. Level mid-shoulder***1968 Château Mouton Rothschild** (1)
*Corroded capsule. Badly stained and damaged label. Level mid-shoulder***1971 Château Mouton Rothschild** (2)
*Slightly stained labels. Levels base of neck***1977 Château Mouton Rothschild** (1)
*Depressed and fragile cork. Stained label. Level upper-shoulder***1978 Château Mouton Rothschild** (1)
*Slightly stained label. Level top-shoulder***1979 Château Mouton Rothschild** (2)
*One slightly depressed cork. Very slightly stained and very slightly damaged labels. Levels top-shoulder*5085 Above 8 bottles *per lot* HK\$14,000-26,000

Mixed 1980's Château Mouton Rothschild**1980 Château Mouton Rothschild** (1)

Very slightly damaged capsule and label. Level very top-shoulder

1981 Château Mouton Rothschild (1)

Slightly stained label. Level base of neck

1984 Château Mouton Rothschild (1)

Slightly stained label. Level upper-shoulder

1987 Château Mouton Rothschild (1)

Slightly damaged label. Level base of neck

5086 Above 4 bottles per lot HK\$6,500-11,000

Mixed Formats of Château Mouton Rothschild 1986**1986 Château Mouton Rothschild** magnum (1)

Stained and very slightly damaged label. Level into neck

1986 Château Mouton Rothschild (3)

One damaged capsule. Two slightly stained and very slightly damaged labels, one stained and damaged labels. Levels two base of neck and one top-shoulder

5087 Above 1 magnum and 3 bottles per lot HK\$26,000-42,000

Mixed 1990's Château Mouton Rothschild**1990 Château Mouton Rothschild** (1)

Very slightly stained label. Stained back label. Level base of neck

1993 Château Mouton Rothschild (2)

US version front labels, one very slightly damaged. Levels into neck

1996 Château Mouton Rothschild (1)

Slightly damaged label. Level into neck

1999 Château Mouton Rothschild (1)

Slightly stained label. Level just into neck

5088 Above 5 bottles per lot HK\$12,000-20,000

Mixed Formats of Château Mouton Rothschild 1996**1996 Château Mouton Rothschild** magnums (2)

One stained, one very slightly stained and one very slightly damaged labels. Levels into neck

1996 Château Mouton Rothschild (7)

Three slightly stained and one very slightly damaged labels. Levels into neck

5089 Above 2 magnums and 7 bottles per lot HK\$32,000-55,000

Vertical of Château Mouton Rothschild 1945-2005**1945 Château Mouton Rothschild** (1)

Corroded capsule, cut to reveal branded cork.

Recorded at Château in 1977. Slightly stained and very slightly damaged label. Level mid-upper shoulder

1946 Château Mouton Rothschild (1)

Slightly damaged capsule. Stained and slightly damaged label. Level mid-upper shoulder

1947 Château Mouton Rothschild (1)

Slightly damaged capsule. Slightly stained label. Level mid-low shoulder

1948 Château Mouton Rothschild (1)

Slightly stained and very slightly damaged label. Level upper-shoulder

1949 Château Mouton Rothschild (1)

Stained and slightly damaged label. Level mid-upper shoulder

1950 Château Mouton Rothschild (1)

Stained and very slightly damaged label. Level upper-shoulder

1951 Château Mouton Rothschild (1)

Damaged capsule. Stained label. Level mid-shoulder

1952 Château Mouton Rothschild (1)

New capsule. Believed recently recorked. Slightly damaged label. Level base of neck

1953 Château Mouton Rothschild (1)

Damaged capsule. Slightly stained label. Level upper-shoulder

1954 Château Mouton Rothschild (1)

Slightly stained and very slightly damaged label. Level upper-shoulder

1955 Château Mouton Rothschild (1)

Sign of old seepage. Slightly stained and slightly damaged label. Level upper-shoulder

1956 Château Mouton Rothschild (1)

Sign of old seepage. Corroded capsule. Stained and damaged label. Level upper-shoulder

1957 Château Mouton Rothschild (1)

Very slightly stained and slightly damaged label. Level upper-shoulder

1958 Château Mouton Rothschild (1)

Slightly protruding cork. Slightly stained and damaged label. Level top-shoulder

1959 Château Mouton Rothschild (1)

Corroded capsule. Stained label. U.S. import slip label. Level top-shoulder

1960 Château Mouton Rothschild (1)

Sign of old seepage. Stained and slightly damaged label. Level upper-shoulder

1961 Château Mouton Rothschild (1)

Slightly stained and very slightly damaged label. Level very top-shoulder

1962 Château Mouton Rothschild (1)

Sign of old seepage. Corroded capsule. Stained and damaged label. Level low-shoulder

1963 Château Mouton Rothschild (1)

Sign of old seepage. Damaged capsule. Stained and slightly damaged label. Level upper-shoulder

1964 Château Mouton Rothschild (1)

Stained and slightly damaged label. Level upper-shoulder

1965 Château Mouton Rothschild (1)
Badly damaged capsule. Slightly stained and slightly damaged label. Level upper-shoulder

1966 Château Mouton Rothschild (1)
Slightly damaged capsule. Stained label. Level upper-shoulder

1967 Château Mouton Rothschild (1)
Stained and slightly damaged label. Level top-shoulder

1968 Château Mouton Rothschild (1)
Very slightly damaged capsule. Stained and very slightly damaged label. Level mid-upper shoulder

1969 Château Mouton Rothschild (1)
Slightly damaged capsule. Stained and very slightly damaged label. Level upper-shoulder

1970 Château Mouton Rothschild (1)
Damaged capsule. Stained and very slightly damaged label. Level upper-shoulder

1971 Château Mouton Rothschild (1)
Very slightly damaged capsule. Stained label. Level mid-low shoulder

1972 Château Mouton Rothschild (1)
Very slightly damaged capsule. Stained label. Level mid-low shoulder

1973 Château Mouton Rothschild (1)
Stained label. Level top-shoulder

1974 Château Mouton Rothschild (1)
Stained and very slightly damaged label. Level top-shoulder

1975 Château Mouton Rothschild (1)
Corroded capsule. Sign of old seepage. Badly stained label. Level mid-shoulder

1976 Château Mouton Rothschild (1)
Very slightly damaged capsule. Badly stained label. Level upper-shoulder

1977 Château Mouton Rothschild (1)
Stained label. Level mid-shoulder

1978 Château Mouton Rothschild (1)
Slightly stained and very slightly damaged label. Level top-shoulder

1979 Château Mouton Rothschild (1)
Slightly stained and slightly damaged label. Level top-shoulder

1980 Château Mouton Rothschild (1)
Slightly damaged label. Level top-shoulder

1981 Château Mouton Rothschild (1)
Slightly damaged capsule. Slightly stained label. Level base of neck

1982 Château Mouton Rothschild (1)
Slightly damaged capsule. Slightly stained label. Level into neck

1983 Château Mouton Rothschild (1)
Slightly damaged capsule. Slightly stained label. Level base of neck

1984 Château Mouton Rothschild (1)
Very slightly damaged label. Level base of neck

1985 Château Mouton Rothschild (1)
Slightly corroded capsule. Slightly stained label. Level base of neck

1986 Château Mouton Rothschild (1)
Sign of old seepage. Slightly damaged label. Japanese slip label. Level into neck

1987 Château Mouton Rothschild (1)
Sign of old seepage. Slightly stained label. Level base of neck

1988 Château Mouton Rothschild (1)
Sign of old seepage. Very slightly damaged label. Level base of neck

1989 Château Mouton Rothschild (1)
Sign of old seepage. Slightly stained label. Level base of neck

1990 Château Mouton Rothschild (1)
Sign of old seepage. Level base of neck

1991 Château Mouton Rothschild (1)
Very slightly stained label. Level into neck

1992 Château Mouton Rothschild (1)
Level into neck

1993 Château Mouton Rothschild (1)
Very slightly stained Balthus label. Level into neck

1994 Château Mouton Rothschild (1)
Very slightly stained label. Level into neck

1995 Château Mouton Rothschild (1)
Slightly stained label. Level into neck

1996 Château Mouton Rothschild (1)
Slightly stained label. U.S. import back label. Level into neck

1997 Château Mouton Rothschild (1)
Very slightly stained label. Level into neck

1998 Château Mouton Rothschild (1)
Very slightly stained and very slightly damaged label. Level into neck

1999 Château Mouton Rothschild (1)
Very slightly damaged label. Level into neck

2000 Château Mouton Rothschild (1)
Level into neck

2001 Château Mouton Rothschild (1)
Very slightly stained label

2002 Château Mouton Rothschild (1)
Very slightly stained label

2003 Château Mouton Rothschild (1)
Wrinkled label

2004 Château Mouton Rothschild (1)
Slightly stained and very slightly damaged label

2005 Château Mouton Rothschild (1)

5090 Above 61 bottles per lot HK\$550,000-1,200,000

Château Margaux 1953

*Margaux, 1er cru classé
 One cut capsule to reveal branded cork. Two J. Calvet import slip labels. Slightly stained labels. Levels two top-shoulder and one upper-shoulder*

5091 3 bottles per lot HK\$20,000-35,000

Château Margaux 1982

*Margaux, 1er cru classé
Two slightly stained and one slightly damaged labels.
Two US import slip labels. Levels five base of neck and
one top-shoulder*

5092 6 bottles *per lot* HK\$32,000-55,000

Château Margaux 1986

*Margaux, 1er cru classé
In original wooden case. Very slightly damaged
capsules. One sign of old seepage. Levels nine base of
neck and three top-shoulder*

5093 12 bottles *per lot* HK\$42,000-70,000

Château Margaux 1990

*Margaux, 1er cru classé
Two very slightly depressed corks. Slightly stained and
four very slightly damaged labels. Levels one into neck
and five base of neck*

5094 6 bottles *per lot* HK\$35,000-60,000

Château Margaux 1990

*Margaux, 1er cru classé
Three slightly stained and three slightly damaged
labels. One US import slip label. Levels nine into neck
and three base of neck*

5095 12 bottles *per lot* HK\$70,000-120,000

Château Margaux 1995

*Margaux, 1er cru classé
Five very slightly damaged labels. Levels into neck*

5096 6 magnums *per lot* HK\$45,000-75,000

Château Margaux 1995

*Margaux, 1er cru classé
One sign of old seepage. Very slightly stained labels,
five very slightly damaged. Levels into neck*

5097 9 bottles *per lot* HK\$35,000-55,000

Château Margaux 1996

*Margaux, 1er cru classé
Very slightly stained and very slightly damaged label.
Level into neck*

5098 1 jeroboam *per lot* HK\$22,000-35,000

Château Margaux 1996

*Margaux, 1er cru classé
Eleven slightly stained labels. One US import slip label.
Levels into neck*

5099 18 bottles *per lot* HK\$65,000-100,000

Château Margaux 2000

*Margaux, 1er cru classé
One sign of old seepage. Slightly damaged labels*

5100 8 bottles *per lot* HK\$45,000-75,000

Château Margaux 2000

*Margaux, 1er cru classé
Two very slightly stained and five very slightly damaged
labels*

5101 17 half-bottles *per lot* HK\$48,000-80,000

Mixed Château Margaux 1978 & 1983

1978 Château Margaux (2)
*Slightly stained and slightly damaged labels. US import
slip labels. Levels upper-shoulder*

1983 Château Margaux (1)
US import slip label. Level base of neck

5102 Above 3 bottles *per lot* HK\$7,000-12,000

Mixed Formats of Château Margaux 1985

1985 Château Margaux magnums (2)
Very slightly stained labels. Levels into neck

1985 Château Margaux (3)
*One slightly depressed cork. One slightly stained, two
stained and two slightly damaged labels. Levels one
base of neck and two top-shoulder*

5103 Above 2 magnums and 3 bottles
per lot HK\$19,000-32,000

Mixed Château Margaux 2001 & 2003 in Half-Bottles

2001 Château Margaux half-bottles (2)

Very slightly stained labels

2003 Château Margaux half-bottles (8)

Slightly stained and five slightly damaged labels.

Stained US import slip labels

5104 Above 10 half-bottles per lot HK\$18,000-28,000

Château Palmer 1945

Cantenac (Margaux), 3ème cru classé

Depressed cork. Slightly stained label. Level top-shoulder

5105 1 bottle per lot HK\$18,000-30,000

Château Palmer 1961

Cantenac (Margaux), 3ème cru classé

Two recent capsules, believed recently recorked. One faded label. Two integrated Mahler-Besse labels. One US import slip label. Levels two into neck and one low-shoulder

5106 3 bottles per lot HK\$50,000-85,000

Lots 5105-5114

Crispy Fried Pigeon and Château Palmer

Crispy Fried Pigeon is a renowned Cantonese dish. Made with squab pigeons of about one month of age, the meat is tender, juicy and is much appreciated for its tonifying effects and health benefits. This dish can be made by deep-frying the pigeon, or deep-frying after pre-cooking or pre-roasting.

Deep-frying raw pigeon is rarely used, as it is a quick fix method that does not yield the authentic taste of crispy pigeons. The more common method is pre-cooking the pigeons in a marinade made with stock and spices, to imbue the meat with flavours before deep-frying the birds. This process also helps preserve the tenderness of the meat and prevent loss of moisture during frying. Pre-roasting the pigeons is a method resembling that of the Peking duck: before frying, the birds are roasted in low to medium heat in an oven to seal in moisture and preserve the natural texture of the meat.

The succulent pigeon meat below the crispy skin has an intense game flavour, and is best paired with a bottle of Château Palmer of Margaux, Bordeaux. Delicate and silkily tannic, the wine will set off the crunchy, caramelised skin whereas the rich taste of the pigeon meat is perfect savoured with the dark fruits and spiced aromas of cabernet sauvignon.

Early 2016. Austin Zhang

Château Palmer 1961

Cantenac (Margaux), 3ème cru classé

Four original capsules, two corroded. Eight recent capsules, recorked in 1998. Four slightly stained, two slightly damaged and one damaged labels. Two Mahler-Besse neck labels. Eight integrated Mahler-Besse labels. Levels five into neck, five base of neck, one top-shoulder and one upper-shoulder

5107 12 bottles per lot HK\$200,000-350,000

Château Palmer 1983

Cantenac (Margaux), 3ème cru classé

In original wooden case with replacement lid. One damaged capsule. One sign of old seepage. Three integrated Mahler-Besse and eight integrated Gallaire & Fils labels. Seven very slightly damaged and five slightly damaged labels. Levels eight base of neck, three top-shoulder and one upper-shoulder

5108 12 bottles per lot HK\$32,000-55,000

Château Palmer 1983

Cantenac (Margaux), 3ème cru classé

Two slightly depressed corks. Two signs of old seepage. Five slightly damaged integrated Mahler-Besse labels. Levels three base of neck and nine top-shoulder

5109 12 bottles per lot HK\$32,000-55,000

Château Palmer 1989

Cantenac (Margaux), 3ème cru classé

In twelve-bottle original wooden case. Three very slightly damaged capsules. Five slightly damaged integrated Mahler-Besse labels. Levels three into neck and five base of neck

5110 8 bottles per lot HK\$16,000-26,000

Château Palmer 1989

Cantenac (Margaux), 3ème cru classé

Lot 5111: Mahler-Besse slip labels. Excellent appearance. Levels nine into neck and three base of neck

Lot 5112: Mahler-Besse slip labels. One very slightly damaged label otherwise excellent appearance. Levels into neck

5111 12 bottles per lot HK\$24,000-40,000

5112 12 "

Château Palmer 2010

*Cantenac (Margaux), 3ème cru classé
Five very slightly damaged labels*

5113 19 bottles per lot HK\$35,000-60,000

Château Palmer 2010

*Cantenac (Margaux), 3ème cru classé
One missing capsule. Five very slightly damaged labels*

5114 24 bottles per lot HK\$42,000-75,000

Château Haut-Brion 1947

*Pessac (Graves), 1er cru classé
Slightly corroded capsule. Stained label. Level mid-upper shoulder*

5115 1 magnum per lot HK\$18,000-30,000

Château Haut-Brion 1959

*Pessac (Graves), 1er cru classé
One corroded capsule. One slightly stained and one slightly damaged labels. Levels one 5cms and one 6cms*

5116 2 bottles per lot HK\$20,000-32,000

Château Haut-Brion 1989

*Pessac (Graves), 1er cru classé
Lot 5117: Two stained and two faded labels. Levels eleven 1.5cms and one 2cms
Lot 5118: One integrated US label, two US import slip labels. Four very slightly damaged and one faded labels. Levels 1.5cms or better*

5117 12 bottles per lot HK\$110,000-180,000

5118 12 "

Château Haut-Brion 1989

*Pessac (Graves), 1er cru classé
Five slightly stained, two very slightly stained, three slightly damaged and one faded labels. Levels nine 1.5cms or better and two 2cms*

5119 11 bottles per lot HK\$100,000-170,000



Lot 5108



Lot 5118

Château Haut-Brion 1995

*Pessac (Graves), 1er cru classé
In original wooden case. Sign of old seepage. Very
slightly stained label. Level into neck*

5120 1 impérial *per lot* HK\$20,000-35,000

Château Haut-Brion 1995

*Pessac (Graves), 1er cru classé
Slightly stained and very slightly damaged labels.
Levels 2cms or better*

5121 5 magnums *per lot* HK\$24,000-42,000

Château Haut-Brion 1995

*Pessac (Graves), 1er cru classé
Four slightly stained and one very slightly damaged
labels. Two US import back labels. Levels 1cm or better*

5122 9 bottles *per lot* HK\$22,000-38,000

Château Haut-Brion 2000

*Pessac (Graves), 1er cru classé
Four very slightly damaged labels. Levels 1cm or better*

5123 6 bottles *per lot* HK\$28,000-45,000

Château Haut-Brion 2003

*Pessac (Graves), 1er cru classé
Very slightly damaged label. Level into neck*

5124 1 double-magnum *per lot* HK\$9,500-15,000

Château Haut-Brion 2005

*Pessac (Graves), 1er cru classé
Very slightly stained label*

5125 1 double-magnum *per lot* HK\$20,000-32,000

Château Haut-Brion 2009

*Pessac (Graves), 1er cru classé
In original wooden case. Sign of old seepage. Slightly
stained label*

5126 1 impérial *per lot* HK\$35,000-55,000

Mixed Formats of Château Haut-Brion 1961 & 1989

1961 Château Haut-Brion (1)
*Slightly stained and slightly damaged label. Level
2.5cms*

1961 Château Haut-Brion half-bottles (2)
*One slightly depressed cork. Slightly damaged
capsules. Slightly damaged labels. US import slip
labels. Levels one 3.5cms and one 4.5cms*

1989 Château Haut-Brion half-bottles (5)
*Four very slightly stained and four very slightly
damaged labels. Levels into neck*
5127 Above 1 bottle and 7 half-bottles
per lot HK\$48,000-75,000

Mixed Château Haut-Brion 1975 & 1985

1975 Château Haut-Brion (2)
*One damaged capsule. Stained and one slightly
damaged labels. Levels 2.5cms*

1985 Château Haut-Brion (2)
Slightly damaged labels. Levels 2.5cms
5128 Above 4 bottles *per lot* HK\$11,000-18,000

Château La Mission-Haut-Brion 1945

*Pessac (Graves), cru classé
One sign of seepage. Corroded and damaged corks.
Stained labels. Nicolas-stamped labels. Levels one
mid-upper shoulder and two mid-shoulder*

5129 3 bottles *per lot* HK\$40,000-90,000

Château La Mission-Haut-Brion 1949

*Pessac (Graves), cru classé
Signs of old seepage. Corroded capsule. One slightly
depressed cork. Slightly damaged labels. Levels
upper-shoulder*

5130 2 bottles *per lot* HK\$35,000-55,000

Château La Mission-Haut-Brion 1961*Pessac (Graves), cru classé**Slightly depressed corks. Stained and one damaged labels. Levels one mid-upper shoulder, one mid-shoulder and one mid-low shoulder*5131 3 bottles *per lot* HK\$35,000-80,000**Château La Mission-Haut-Brion 1975***Pessac (Graves), cru classé**Damaged and slightly corroded capsules. Slightly stained labels, one very slightly damaged. Levels very top-shoulder*5132 3 magnums *per lot* HK\$40,000-65,000**Château La Mission-Haut-Brion 1975***Pessac (Graves), cru classé**Lot 5133: Two very slightly damaged capsules. Two signs of old seepage. Stained labels. Taiwanese import back labels. Levels eight top-shoulder and two upper-shoulder**Lot 5134: Two signs of old seepage. Eight slightly corroded and two very slightly damaged capsules. Six US import slip labels. Slightly stained and three damaged labels. Levels six base of neck, two top-shoulder and two upper-shoulder*5133 10 bottles *per lot* HK\$65,000-110,000

5134 10 "

Château La Mission-Haut-Brion 1982*Pessac (Graves), cru classé**Seven slightly damaged capsules. Two very slightly protruding corks. One very slightly stained and three very slightly wrinkled labels. Six integrated US import labels and two US import slip labels. Levels three into neck, two base of neck and six top-shoulder*5135 11 bottles *per lot* HK\$70,000-120,000**Château La Mission-Haut-Brion 1989***Pessac (Graves), cru classé**Very slightly stained labels. Levels into neck*5136 7 bottles *per lot* HK\$42,000-70,000**Château La Mission-Haut-Brion 2009***Pessac (Graves), cru classé**Very slightly stained label. Level into neck*5137 1 impérial *per lot* HK\$30,000-50,000**Mixed Château La Mission-Haut-Brion 1953 & 1959****1953 Château La Mission-Haut-Brion** (1)*Stained Nicolas-stamped label. Level base of neck***1959 Château La Mission-Haut-Brion** (3)*One corroded capsule. Stained and slightly damaged labels. Levels one into neck, one top-shoulder and one mid-shoulder*5138 Above 4 bottles *per lot* HK\$40,000-90,000**Petrus 1964***Pomerol, cru exceptionnel**One cut capsule to reveal branded cork. One very slightly damaged label. Levels three top-shoulder and two upper-shoulder*5139 5 bottles *per lot* HK\$80,000-130,000**Petrus 1975***Pomerol, cru exceptionnel**Slightly damaged capsule. Slightly protruding cork. Integrated US import label. Level top-shoulder*5140 1 jeroboam *per lot* HK\$65,000-110,000

Lots 5139-5151

Roast lamb chops and Petrus

"Boundless is the sky, infinite are the plains. Herds and flocks can be seen when grass bows to the wind."(Anon. Northern Dynasty) On the vast plains, nothing is more exhilarating than the fragrance of lamb roasting on a bonfire, accompanied by fine wine and a welcoming host. Roast lamb chops sound like an easy dish, but one must constantly rotate the spit onto which the meat is skewered to ensure even cooking of the meat. The finished lamb is lightly charred on the outside and juicy on the inside, offering an explosion of flavours on the palate. A deep and powerful Merlot with fruity aromas is great with this dish. Petrus made with 100% Merlot is an excellent choice. Indubitably the king of Bordeaux, Petrus' wine is priced above those of the five big names of the Left Bank, and produces only 30,000 bottles per year, adding to its rarity. A bottle of Petrus is often characterised by its hugely expressive bouquet with fruit and caramel notes, totally ripe tannins, opulent body and a glorious, long finish.

Early 2016. Austin Zhang.

Petrus 1982

Pomerol, cru exceptionnel
 Two damaged capsules, one slightly depressed cork.
 US import slip labels. Slightly stained labels. Levels
 into neck

5141 3 bottles per lot HK\$65,000-110,000

Petrus 1989

Pomerol, cru exceptionnel
 Two very slightly damaged capsules. Two slightly
 stained and one slightly damaged labels. Levels into
 neck

5142 5 bottles per lot HK\$120,000-190,000

Petrus 1990

Pomerol, cru exceptionnel
 Six slightly damaged labels. One slightly damaged
 integrated US label. One Japanese import slip label.
 Levels seven into neck and five base of neck

5143 12 bottles per lot HK\$280,000-450,000

Petrus 1998

Pomerol, cru exceptionnel
 Nine integrated US import labels. Levels base of neck

5144 10 bottles per lot HK\$180,000-300,000

Petrus 2000

Pomerol, cru exceptionnel
 One US import slip label. Levels base of neck

5145 5 bottles per lot HK\$120,000-220,000

Petrus 2001

Pomerol, cru exceptionnel
 Sign of old seepage. Very slightly stained integrated US
 import label

5146 1 double-magnum per lot HK\$55,000-90,000

Petrus 2004

Pomerol, cru exceptionnel

5147 6 bottles per lot HK\$70,000-120,000

Petrus 2006

Pomerol, cru exceptionnel

5148 3 bottles per lot HK\$35,000-60,000

Petrus 2013

Pomerol, cru exceptionnel

5149 12 bottles per lot HK\$160,000-260,000

Mixed Formats of Petrus 1975, 1987, 1992, 1997 & 2001

1975 Petrus half-bottle (1)
Very slightly corroded and very slightly damaged
capsule. Stained and very slightly damaged label. Level
top-shoulder

1987 Petrus (1)
Sign of old seepage. Very slightly corroded capsule.
Level just base of neck

1992 Petrus (1)
Very slightly stained and very slightly damaged
integrated US import label. Japanese import slip label.
Level base of neck

1997 Petrus (2)
One very slightly damaged label. Italian import slip
labels. Levels base of neck

2001 Petrus (1)

5150 Above 5 bottles and 1 half-bottle
 per lot HK\$60,000-110,000

Mixed Petrus 1996, 1999 & 2013 in Magnum

1996 Petrus magnum (1)
Good appearance. Level into neck

1999 Petrus magnum (1)
Good appearance. Level into neck

2013 Petrus magnum (1)

5151 Above 3 magnums per lot HK\$70,000-120,000

Le Pin 1995

Pomerol
 Two stained and six slightly stained labels. Levels just
 into neck

5152 8 bottles per lot HK\$100,000-160,000

Le Pin 1998*Pomerol**Sign of old seepage. Damaged capsule. Very slightly stained and very slightly damaged label. US import slip label. Level base of neck*

5153 1 double-magnum per lot HK\$70,000-110,000

Le Pin 2002*Pomerol**Five Congée capsules over original capsules. One slightly stained label. Levels base of neck or better*

5154 10 bottles per lot HK\$100,000-160,000

Le Pin 2009*Pomerol**Damaged capsule. Protruding cork. Sign of old seepage. Stained and slightly damaged label*

5155 1 double-magnum per lot HK\$80,000-130,000

Mixed Le Pin 1979, 1985 & 1989**1979 Le Pin** (1)*Very slightly damaged capsule. Slightly stained label. Level base of neck***1985 Le Pin** (1)*Depressed cork. Stained label. Level top-shoulder***1989 Le Pin** (5)*One corroded capsule. Three slightly depressed corks. Stained labels. Levels four base of neck and one top-shoulder*

5156 Above 7 bottles per lot HK\$130,000-200,000

Mixed Le Pin 1994, 1996, 1997 & 1998**1994 Le Pin** (1)*Very slightly stained label***1996 Le Pin** (2)*One very slightly stained label. Levels into neck***1997 Le Pin** (5)*Slightly stained labels, one very slightly damaged. Levels base of neck or better***1998 Le Pin** (2)*Very slightly stained labels. US import slip labels. Levels base of neck*

5157 Above 10 bottles per lot HK\$110,000-180,000

Clos L'Eglise Clinet 1950*Pomerol**Very slightly damaged capsule. Stained and slightly damaged label. US import slip label. Level mid-low shoulder*

5158 1 bottle per lot HK\$3,000-8,000

Mixed Formats of Château Clinet 1989**1989 Château Clinet**

double-magnums (2)

*Slightly damaged wax capsules. Signs of old seepage. Levels one base of neck, one top-shoulder***1989 Château Clinet**

magnum (1)

Slightly damaged capsule. Badly stained and slightly damaged label. Level into neck

5159 Above 2 double-magnums and 1 magnum per lot HK\$32,000-55,000

Château Lafleur 1975*Pomerol**One very slightly depressed cork. One very slightly corroded and two slightly damaged capsules. One badly stained, two very slightly stained, one damaged and one creased labels. Three US import slip labels. Levels one top-shoulder and three upper-shoulder*

5160 4 bottles per lot HK\$75,000-120,000

Château Lafleur 1982*Pomerol**Four signs of old seepage. Four slightly depressed corks. One cut capsule to reveal fully branded cork. Three very slightly damaged capsules. Five stained labels. Three integrated US and one integrated Swiss import labels. One US import slip label. Levels one into neck, one base of neck and three top-shoulder*

5161 5 bottles per lot HK\$110,000-190,000

Château Lafleur 1990*Pomerol**Lot 5162: Stained and slightly damaged labels.**Levels one into neck and three base of neck**Lot 5163: Stained and two slightly damaged labels.**One integrated US import label. Levels base of neck*

5162 4 bottles per lot HK\$35,000-60,000

5163 4 "

Mixed Château Lafleur 1966 & 1979**1966 Château Lafleur** (1)

Badly stained and slightly damaged label. Level base of neck

1979 Château Lafleur (3)

One slightly damaged capsule. Badly stained labels. One integrated US import label. Levels two base of neck and one top-shoulder

5164 Above 4 bottles per lot HK\$42,000-70,000

Mixed Château Lafleur 1993, 1994 & 2001**1993 Château Lafleur** (3)

Slightly stained integrated US import labels, one very slightly damaged. Levels base of neck

1994 Château Lafleur (3)

Two very slightly damaged labels. Levels base of neck

2001 Château Lafleur (5)

Two slightly depressed corks. Slightly stained and slightly damaged labels

5165 Above 11 bottles per lot HK\$24,000-38,000

Château Latour à Pomerol 1982

Pomerol

Two slightly depressed corks. Stained and very slightly damaged labels. Levels top-shoulder

5166 5 bottles per lot HK\$8,000-13,000

Château L'Evangile 1961

Pomerol

One very slightly damaged capsule. Very slightly stained labels. Levels top and upper-shoulder

5167 2 bottles per lot HK\$35,000-60,000

Château Trotanoy 1945

Pomerol

Slightly damaged capsules. Slightly depressed corks. Stained and slightly damaged Nicolas-stamped labels. Levels top-shoulder

5168 3 bottles per lot HK\$55,000-90,000

Vieux Château Certan 1947

Pomerol

Stained and slightly damaged labels. US import slip labels. Levels one base of neck and one top-shoulder

5169 2 bottles per lot HK\$26,000-45,000

Vieux Château Certan 1948

Pomerol

Stained and slightly damaged labels. US import slip labels. Levels three base of neck and one top-shoulder

5170 4 bottles per lot HK\$32,000-55,000

Château Ausone 1945

Saint-Emilion, 1er grand cru classé

Damaged capsule. Stained label. Level mid-shoulder

5171 1 bottle per lot HK\$13,000-20,000

5172 NO LOT

5173 NO LOT



Château Cheval-Blanc 1947

Saint-Émilion, 1er grand cru classé (A)
 Lot 5174: Sign of old seepage. Reconditioned at Château in 1994. Stained and slightly damaged label. Level into neck
 Lot 5175: Stained and slightly damaged label. Reconditioned at Château in 1994. Level into neck
 Lot 5176: Damaged capsule, bottom part missing. Stained and slightly damaged label. Reconditioned at Château in 1994. Level into neck

5174 1 bottle per lot HK\$65,000-110,000
 5175 1 "
 5176 1 "

Château Cheval-Blanc 1947

Saint-Émilion, 1er grand cru classé (A)
 Very slightly depressed cork. Stained and very slightly damaged label. Level mid-upper shoulder

5177 1 half-bottle per lot HK\$26,000-50,000

Château Cheval-Blanc 1949

Saint-Émilion, 1er grand cru classé (A)
 Badly damaged capsule. Badly stained and damaged label. Level upper-shoulder

5178 1 magnum per lot HK\$35,000-55,000

Château Cheval-Blanc 1949

Saint-Émilion, 1er grand cru classé (A)
 One reconditioned at Château in 1995, two reconditioned in 1999. Slightly stained and slightly damaged labels. Levels into neck

5179 3 bottles per lot HK\$50,000-85,000

Château Cheval-Blanc 1955

Saint-Émilion, 1er grand cru classé (A)
 One corroded capsule. Slightly depressed corks. Very slightly stained labels. Cruse & Fils neck slip labels, one damaged. Levels one base of neck and one top-shoulder

5180 2 magnums per lot HK\$24,000-42,000

Château Cheval-Blanc 1982

Saint-Émilion, 1er grand cru classé (A)
 Six slightly corroded and three very slightly damaged capsules. Eight very slightly depressed corks. Slightly stained, seven very slightly damaged and one damaged labels. Two stained US import slip labels. Levels thirteen base of neck and two top-shoulder

5181 15 bottles per lot HK\$75,000-130,000

Château Cheval-Blanc 2001

Saint-Émilion, 1er grand cru classé (A)
 Very slightly stained, three very slightly damaged and one very slightly creased labels

5182 11 half-bottles per lot HK\$12,000-22,000

Mixed Château Cheval-Blanc 1950, 1953 & 1955**1950 Château Cheval-Blanc** (9)

Five corroded and four slightly corroded capsules. Four slightly depressed corks. Three Cruse & Fils Frères Bordeaux slip labels. Seven stained, two badly stained and two damaged labels. Levels five top-shoulder, three upper-shoulder and one mid-shoulder

1953 Château Cheval-Blanc (1)

Slightly corroded capsule. Slightly damaged label. Level mid-shoulder

1955 Château Cheval-Blanc (1)

Slightly corroded capsule. Slightly depressed cork. Slightly stained label. US import slip label. Level top-shoulder

5183 Above 11 bottles per lot HK\$95,000-180,000

Château d'Yquem 1921

Sauternes, 1er grand cru classé
 Damaged capsule. Badly stained and damaged label. US import slip label. Level top-shoulder

5184 1 bottle per lot HK\$35,000-60,000

Château d'Yquem 1949

Sauternes, 1er grand cru classé
 Stained labels. US import slip labels. Levels one base of neck and one top-shoulder

5185 2 bottles per lot HK\$19,000-32,000

Château d'Yquem 1967

*Sauternes, 1er grand cru classé
Signs of old seepage. Very slightly damaged capsules.
Stained and one damaged labels. One US import slip
label. Levels one base of neck and one top-shoulder*

5186 2 bottles *per lot* HK\$12,000-19,000

Château d'Yquem 1975

*Sauternes, 1er grand cru classé
Two damaged capsules. Three signs of old seepage.
Very slightly stained, one stained and two slightly
damaged labels. US import slip labels. Levels top-
shoulder*

5187 12 bottles *per lot* HK\$48,000-80,000

Château d'Yquem 1983

*Sauternes, 1er grand cru classé
Seven signs of old seepage. One damaged capsule.
One protruding cork. US import slip labels. Levels very
top-shoulder*

5188 12 bottles *per lot* HK\$22,000-35,000

Château d'Yquem 1990

*Sauternes, 1er grand cru classé
One protruding cork. Very slightly stained and two very
slightly damaged labels. Levels base of neck*

5189 6 bottles *per lot* HK\$11,000-18,000

Mixed Château d'Yquem 1934, 1959 & 1975

1934 Château d'Yquem (1)

Very slightly damaged label. Level into neck

1959 Château d'Yquem (1)

*Corroded and slightly damaged capsule. US import slip
label. Stained and damaged label. Level top-shoulder*

1975 Château d'Yquem (1)

*Very slightly damaged capsule. Very slightly stained
and slightly damaged label. US import slip label.
Level top-shoulder*

5190 Above 3 bottles *per lot* HK\$22,000-35,000

Mixed Bouchard Père & Fils, Montrachet 1996 & 1999

1996 Bouchard Père & Fils, Montrachet (2)

*Very slightly damaged capsule. One very slightly
damaged neck label. Levels 1cm*

1999 Bouchard Père & Fils, Montrachet (7)

*One very slightly damaged vintage neck label. US
import slip labels. Levels six 1cm and one 1.5cms*

5191 Above 9 bottles *per lot* HK\$22,000-35,000

DOMAINE COCHE-DURY

Jean-François Coche began working in the family vineyards alongside his father, Georges, becoming the third generation of Coches to tend the vines. His marriage to Odile Dury in 1975 added to the family holdings, which lead to the formation of Domaine Coche-Dury. Today, his son, Raphaël, has taken over the reins with his wife, Charline.

The Domaine owns 0.34 hectares of Corton Charlemagne which was planted in 1960. They also have significant holdings in Meursault, including 4 hectares of Meursault, 0.33 hectares of 1er Cru Meursault-Caillerets, 0.5 hectares of 1er Cru Meursault-Perrières, 0.7 hectares of Meursault Les Rougeots and 0.12 hectares of Meursault Les Chevalières.

The wine-making is traditional with extended lees contact which prevents oxidation and adds complexity and mouth-feel. All wines are aged in barrel and aged for between 15 to 22 months, depending on the vintage and wine and the percentage of new oak is normally 25% for the white wines. All the wines are bottled unfiltered; the reds are fined with egg whites.

Coche-Dury is undoubtedly one of the finest producers of white Burgundy and the Domaine is most closely associated with the wines from Meursault where they are also based and because much of their holdings are in this appellation. They also produce six Pinot Noirs that are also highly rated, although overshadowed by their stunning whites.

J. F. Coche-Dury, Corton-Charlemagne 1986

Grand Cru, Côte de Beaune

5192 2 bottles *per lot* HK\$55,000-90,000

J. F. Coche-Dury, Corton-Charlemagne 1989

Grand Cru, Côte de Beaune

*Slightly corroded and slightly damaged capsule. Very
slightly damaged vintage neck label. Very slightly
stained and very slightly damaged label. Level 3.5cms*

5193 1 bottle *per lot* HK\$26,000-45,000

J. F. Coche-Dury, Corton-Charlemagne 1990

Grand Cru, Côte de Beaune

Level 1cm

5194 1 bottle *per lot* HK\$20,000-35,000

J. F. Coche-Dury, Corton-Charlemagne 1992

Grand Cru, Côte de Beaune

Sign of old seepage. Very slightly damaged capsule.

Very slightly damaged label. Level 3.5cms

5195 1 magnum *per lot* HK\$35,000-60,000

J. F. Coche-Dury, Corton-Charlemagne 1996

Grand Cru, Côte de Beaune

Two white and one gold capsules. One very slightly damaged vintage neck labels One very slightly stained and two very slightly damaged labels. Two US import slip labels. Levels two 1cm and one 1.5cms

5196 3 bottles *per lot* HK\$65,000-110,000

J. F. Coche-Dury, Corton-Charlemagne 2002

Grand Cru, Côte de Beaune

One sign of old seepage. One slightly stained and very slightly damaged vintage neck labels. Very slightly stained and very slightly damaged labels

5197 2 bottles *per lot* HK\$38,000-65,000

J. F. Coche-Dury, Meursault-Perrières 1992

1er Cru, Côte de Beaune

One damaged label. Levels one 1cm and one 2cms

5198 2 magnums *per lot* HK\$55,000-90,000

Mixed J. F. Coche-Dury, Meursault Les Casse-Tête & Meursault-Perrières 1978

1978 J. F. Coche-Dury, Meursault Les Casse-Tête (2)

Very slightly stained labels. Levels 2cms

1978 J. F. Coche-Dury, Meursault-Perrières (2)

Slightly depressed corks. Very slightly stained labels, one slightly damaged. Levels 2cms

5199 Above 4 bottles *per lot* HK\$40,000-65,000

Mixed J. F. Coche-Dury, Corton-Charlemagne 1988 & 1997

1988 J. F. Coche-Dury, Corton-Charlemagne (1)

Sign of old seepage. Gold capsule. Damaged vintage neck label. Believed 1988. Damaged label. Level 2cms

1997 J. F. Coche-Dury, Corton-Charlemagne (1)

Level 2.5cms

5200 Above 2 bottles *per lot* HK\$26,000-42,000

Mixed Formats of J. F. Coche-Dury, Meursault-Perrières 1989

1989 J. F. Coche-Dury, Meursault-Perrières

magnum (1)

Slightly damaged capsule. Slightly damaged label.

Level 3cms

1989 J. F. Coche-Dury,, Meursault-Perrières (1)

Very slightly damaged capsule. Slightly damaged vintage neck label. Very slightly damaged and slightly stained label. Level 2.2cms

5201 Above 1 magnum and 1 bottle *per lot* HK\$32,000-55,000

Mixed J. F. Coche-Dury, Corton-Charlemagne & Meursault-Perrières 2000

2000 J. F. Coche-Dury, Corton-Charlemagne (2)

Slightly damaged and one very slightly stained vintage neck labels. Slightly damaged and one slightly stained labels. One US import slip label

2000 J. F. Coche-Dury, Meursault-Perrières (2)

One stained vintage neck label. One slightly stained and one stained front labels

5202 Above 4 bottles *per lot* HK\$55,000-95,000



DOMAINE COMTE GEORGES DE VOGÜÉ

The Domaine can trace its history back to 1450 and it is considered by many as the greatest estate in Chambolle Musigny. Since 1989 the Domaine has been run by the estate manager Jean-Luc Pépin, winemaker François Millet (who became the wine maker in 1985) and Eric Bourgogne overseeing the vineyards.

Domaine du Comte Georges de Vogüé owns 12.5 hectares of vineyards including 2.7 hectares of Bonnes-Mares, 0.5 hectares of Chambolle-Musigny Les Amoureuses and 2 hectares of Chambolle-Musigny. The Domaine owns an incredible 7.12 hectares of the fabled Le Musigny vineyard which constitutes 80% of the whole site. The average age of vines in Le Musigny is over 40 years old and is labeled as Vieilles Vignes. Le Musigny comprises two sections which are divided by a path, with the northern part known as Grand Musigny and the southern part Les Petits Musigny, which is wholly owned by de Vogüé. The Domaine has a small section (0.66 hectares) of the vineyard planted with Chardonnay which produced their extremely rare white Le Musigny Grand Cru, although currently the vines are too young and consequently the wine is sold simply as Bourgogne Blanc.

Yields are very low and the grapes are completely destemmed. Fermentation takes place with temperature control to ensure that the temperature does not exceed 32 degrees. The percentage of new oak varies from between 15% for their village wines to 45% for their Grand Cru Musigny and Bonnes Mares.

The Domaine is considered amongst the very best in Burgundy, producing rich, perfumed and deliciously complex wines that at their best can age for half a century or more. Their approximately 400 cases per vintage of Bonnes Mares and particularly their 900 cases of Musigny Vieilles Vignes are some of the most sought-after wines from Burgundy.

Domaine Comte Georges de Vogüé, Musigny Blanc 1992

Grand Cru, Côte de Nuits

Two very slightly damaged labels. Levels two 1.5cms, three 2cms, two 2.5cms and one 3.5cms

5203 8 bottles *per lot* HK\$50,000-85,000

Mixed Domaine Comte Georges de Vogüé, Musigny Blanc 1979 & 1991

1979 Domaine Comte Georges de Vogüé, Musigny Blanc (1)

Stained and slightly damaged label. Mature colour. Level 0.5cm

1991 Domaine Comte Georges de Vogüé, Musigny Blanc (2)

Slightly stained and damaged labels. Levels one 1cm and one 2cms

5204 Above 3 bottles *per lot* HK\$10,000-16,000

Domaine des Comtes Lafon, Montrachet 1989

Grand Cru, Côte de Beaune

Stained and very slightly damaged label. Mature colour. Level 1.2cms

5205 1 bottle *per lot* HK\$16,000-26,000

Domaine des Comtes Lafon, Montrachet 2004

Grand Cru, Côte de Beaune

Very slightly damaged labels. Slightly damaged Italian import back labels

5206 2 bottles *per lot* HK\$14,000-24,000

Domaine des Comtes Lafon, Montrachet 2010

Grand Cru, Côte de Beaune

Dutch import back labels

5207 4 bottles *per lot* HK\$38,000-65,000

Domaine d'Auvenay, Chevalier-Montrachet 1997

Côte de Beaune

Very slightly stained label

5208 1 bottle *per lot* HK\$7,000-12,000

Domaine de la Romanée-Conti, Montrachet 1990

Grand Cru, Côte de Beaune

One mature colour. Very slightly stained labels. One Wilson Daniels and one US import slip labels. Levels one 1.5cms, 2.5cms and one 4cms

5209 3 bottles *per lot* HK\$70,000-120,000

Domaine de la Romanée-Conti, Montrachet 1996*Grand Cru, Côte de Beaune**One very slightly protruding cork. Very slightly stained labels. One integrated HK import back label. Levels one 0.5cm, one 2.5cms and one 3.5cms*5210 3 bottles *per lot* HK\$95,000-150,000**Domaine de la Romanée-Conti, Montrachet 2002***Grand Cru, Côte de Beaune**One very slightly protruding cork. Very slightly stained and two very slightly damaged labels. Two integrated Wilson Daniels and one integrated Italian import back labels. One Japanese import slip label. Levels two 0.5cm and one 1.5cms*5211 3 bottles *per lot* HK\$95,000-150,000**Domaine de la Romanée-Conti, Montrachet 2004***Grand Cru, Côte de Beaune**Signs of old seepage. Two very slightly damaged labels. US import back labels. Levels 1.5cms, 2cms and 2.5cms*5212 3 bottles *per lot* HK\$75,000-120,000**Domaine de la Romanée-Conti, Montrachet 2006***Grand Cru, Côte de Beaune**One slightly damaged label. Two US import back labels*5213 3 bottles *per lot* HK\$80,000-140,000**Mixed DRC Montrachet 2003 & 2004****2003 Domaine de la Romanée-Conti, Montrachet (1)***Very slightly stained label and damaged back label.**Level 2cms***2004 Domaine de la Romanée-Conti, Montrachet (2)***Very slightly damaged labels. One US and one damaged HK import back labels. Levels 2.5cms and 3 cms*5214 Above 3 bottles *per lot* HK\$75,000-130,000**DOMAINE LEFLAIVE**

The earliest family history goes back to 1717 when Claude Leflaive settled in Puligny-Montrachet. The Domaine of today more directly goes back to Joseph Leflaive (1870-1953), who was a native of Puligny-Montrachet. In 1905, when Burgundy had not yet recovered from the effect of the phylloxera epidemic and therefore vineyards were for sale at a very low price, Leflaive was able to buy 25 hectares. In 1990 Anne-Claude Leflaive and her cousin Vincent Leflaive took over the management of the domain. Today this famous Domaine is run by Anne-Claude Leflaive.

The Domaine owns almost 25 hectares of vineyards mainly located in and around Puligny-Montrachet. Their holdings include 0.08 hectares of Le Montrachet, 2 hectares of Chevalier-Montrachet, 1.91 hectares of Bâtard-Montrachet, 1.6 hectares of Bienvenues-Bâtard-Montrachet and Puligny-Montrachet Premier Crus; Le Clavoillon, Les Combettes, Les Folatières and Les Pucelles. Domaine Leflaive has been totally biodynamic since 1997 and Pierre Morey was estate manager since 1989 until Eric Remy took over in 2008.

The wines are fermented at between 18 to 24° C, given 10-40% light toast new oak (there is one 500-litre cask for the Montrachet) and, after 12 months, racked into stainless steel where they wait another 6 months before bottling.

This is the very summit of white Burgundy. Outstanding wines that have the capacity to be very long-lived and develop richness, depth and complexity with bottle-age. These are some of the most highly sought-after white wines in the world.

Domaine Leflaive, Bâtard-Montrachet 1996*Grand Cru, Côte de Beaune**Two slight signs of old seepage. One very slightly damaged label. Levels seven 1.5cms or better, three 2.5cms and one 3cms*5215 11 bottles *per lot* HK\$35,000-65,000

Domaine Leflaive, Bâtard-Montrachet 1996

*Grand Cru, Côte de Beaune
Four signs of old seepage. One wine stained vintage neck label. Three slightly stained labels. Levels six 1.5cms, three 2cms, two 2.5cms and one 3cms*

5216 12 bottles *per lot HK\$40,000-70,000*

Domaine Leflaive, Bâtard-Montrachet 2006

*Grand Cru, Côte de Beaune
Lot 5217: One sign of old seepage. Three very slightly stained labels. Six integrated UK import back labels and six US import slip labels
Lot 5218: One very slightly damaged label. Some very slightly damaged UK import back labels*

5217 12 bottles *per lot HK\$24,000-40,000*

5218 12 "

Domaine Leflaive, Chevalier-Montrachet 1996

*Côte de Beaune
One very slightly stained, one slightly damaged and four slightly wrinkled labels. One US import slip label. Levels three 1cm, seven 1.5cms and two 2cms*

5219 12 bottles *per lot HK\$65,000-110,000*

Domaine Leflaive, Chevalier-Montrachet 2002

*Côte de Beaune
One slightly damaged capsule. One stained label*

5220 6 bottles *per lot HK\$24,000-40,000*

Domaine Leflaive, Chevalier-Montrachet 2005

*Côte de Beaune
Three very slightly damaged labels*

5221 6 bottles *per lot HK\$24,000-40,000*

Domaine Leflaive, Chevalier-Montrachet 2008

*Côte de Beaune
One sign of old seepage. One wine stained vintage neck label*

5222 12 bottles *per lot HK\$38,000-60,000*



Mixed Domaine Leflaive, Chevalier-Montrachet 1988 & 1996

1988 Domaine Leflaive, Chevalier-Montrachet (2)
Slightly stained vintage neck labels and front labels. Mature colours. Levels 3cms

1996 Domaine Leflaive, Chevalier-Montrachet (2)
One slightly sign of old seepage. Slightly damaged labels. US import slip labels. Levels one 2cms and one 3cms

5223 Above 4 bottles *per lot* HK\$16,000-30,000

Mixed Domaine Leflaive, Chevalier-Montrachet 2000 & 2003

2000 Domaine Leflaive, Chevalier-Montrachet (3)
Two signs of old seepage. One slightly stained label

2003 Domaine Leflaive, Chevalier-Montrachet (6)

5224 Above 9 bottles *per lot* HK\$24,000-38,000

Domaine Leflaive, Montrachet 1999

*Grand Cru, Côte de Beaune
Wrinkled vintage neck labels. One US import slip label.
One very slightly damaged label stamped with "From the cellar of Mark Andrew Levitt"*

5225 2 bottles *per lot* HK\$65,000-100,000

Mixed Formats of Domaine Leflaive, Bâtard-Montrachet & Chevalier-Montrachet 2011

2011 Domaine Leflaive, Chevalier-Montrachet (2)
magnums
One slight sign of old seepage. Very slightly damaged back labels

2011 Domaine Leflaive, Bâtard-Montrachet (6)
Two very slightly damaged labels

5226 Above 2 magnums and 6 bottles *per lot* HK\$24,000-50,000

Mixed Louis Latour, Montrachet & Bâtard-Montrachet

1985 Louis Latour, Montrachet (6)
Four slightly depressed corks. Very slightly stained labels. Mature colours. Levels five 1.5cms or better and one 2cms

1989 Louis Latour, Bâtard-Montrachet (5)
Slightly depressed corks. Very slightly stained labels. US import back labels. Levels four 1cm and one 1.5cms

5227 Above 11 bottles *per lot* HK\$18,000-30,000

Lots 5219-5224

糖醋鯉魚配 Domaine Leflaive Chevalier Montrachet

糖醋鯉魚是正宗的魯菜，發源于齊魯之都濟南，清道光年間《濟南府志》即有記載：「黃河之鯉，南陽之蟹，且入食譜」。黃河是中國的母親河，在中原地區水勢頗急，因此河中生長的鯉魚多動善游，赤尾金鱗，肥美鮮嫩，肉質細膩，《詩經 衡門》便強調「豈其食魚，必河之鯉」。烹製糖醋鯉魚一定要選取個頭大、鮮活有力的黃河鯉魚。烹飪方法與松鼠鱈魚頗為相似，都是花刀入油鍋炸至蓬鬆酥脆，再炒熟的糖、醋、姜、料酒等勾成的芡汁淋于其上即可。黃河鯉魚肉質鮮嫩，糖醋芡汁酸甜可口，搭配勃艮第上好的霞多麗最好。伯恩丘信奉自然動力法的名莊 Leflaive 出產的頂級特級田蒙哈榭，深邃悠遠，口感清冽，果香濃郁且充滿強大的礦物質香氣，是魚肉最好的搭配。

乙未秋日，張儵翰。

Sweet and Sour Yellow River Carp and Domaine Leflaive Chevalier Montrachet

Sweet and sour carp is an exquisite Shangdong cuisine, originally from Jinan, the capital of Shandong. The dish is mentioned in the regional Qing dynasty chronicle, "Jinan Fu Zhi", during Daoguang Emperor's reign; "Carp from the Yellow River, and crab from Nanyang both find their place in cuisine." The Yellow River is the cradle of Chinese civilization. Its rapid course in the Central Plains region is the home of carps that are swift and agile with their impressive red tails and golden fins. The carp flesh contains high oil content with a tender texture. In Hengmen, a chapter in the Chinese classic Book of Poetry, the writer stated, eating fresh carp from the river is a luxurious pleasure. To make sweet and sour carp, one must select fresh, lively carp of decent size from the Yellow River. The cooking process is similar to that of another famous dish, the 'squirrel-shaped mandarin fish.' The sides of the carp are cut with crisscross hatches and then deep-fried till crispy on the outside. A sauce mix made with cooked sugar, vinegar, cooking wine and other seasoning is then poured on top. The delicate carp flesh and the sweet and tangy sauce are best paired with a fine Burgundy Chardonnay. Leflaive from Côte de Beaune is an exceptional domaine in practicing biodynamic agriculture. Their Montrachet Grand Cru are musky and gorgeous, linger on the palate and consist terrific mineral energy in its ripe fruit flavours. It is the perfect company with fish dishes.

Autumn 2015. Austin Zhang

Mixed Bâtard-Montrachet

2001 Domaine Louis Jadot, Bâtard-Montrachet (3)
One slightly damaged label. US import back labels, one damaged

2005 Pierre-Yves Colin-Morey, Bâtard-Montrachet (6)
5228 Above 9 bottles per lot HK\$16,000-28,000

Mixed Domaine Michel Niellon, Chevalier-Montrachet 2002 & 2005

2002 Domaine Michel Niellon, Chevalier-Montrachet (5)
US import slip labels

2005 Domaine Michel Niellon, Chevalier-Montrachet (10)
One very slightly damaged label
5229 Above 15 bottles per lot HK\$30,000-50,000

Domaine Jacques Prieur, Montrachet 2009

*Grand Cru, Côte de Beaune
Three very slightly stained and two very slightly damaged labels. Six integrated UK import back labels*

5230 7 bottles per lot HK\$18,000-30,000

Domaine Jacques Prieur, Montrachet 2009

*Grand Cru, Côte de Beaune
Two very slightly depressed corks. One very slightly damaged vintage neck label. Two very slightly stained and two very slightly damaged labels. Six integrated UK import back labels*

5231 12 bottles per lot HK\$32,000-55,000

Domaine Ramonet, Bâtard-Montrachet 1992

*Grand Cru, Côte de Beaune
Slightly damaged capsules. Two very slightly depressed corks. One slightly stained vintage neck label. Levels 2cms or better*

5232 6 bottles per lot HK\$28,000-48,000

Mixed Domaine Ramonet, Montrachet 1995 & 2006

1995 Domaine Ramonet, Montrachet (4)
One slightly damaged label. US import slip labels. Levels 1cm

2006 Domaine Ramonet, Montrachet (2)
One very slightly damaged label. US import slip labels
5233 Above 6 bottles per lot HK\$32,000-55,000

SATURDAY 26 NOVEMBER · 10.30AM

Lots 5234-5463

Armand Rousseau, Chambertin 1990

*Grand Cru, Côte de Nuits
Two Frederick Wildman neck labels. Slightly stained labels. Levels two 1cm and one 1.5cms*

5234 3 bottles per lot HK\$55,000-95,000

Armand Rousseau, Chambertin 2004

Grand Cru, Côte de Nuits

5235 5 bottles per lot HK\$24,000-42,000

Armand Rousseau, Chambertin-Clos-de-Bèze 1990

*Grand Cru, Côte de Nuits
Two slightly depressed corks. One sign of old seepage. One wine stained vintage neck label. Four slightly stained and one wine stained labels. Two US import slip labels. Levels four 1cm and one 1.5cms*

5236 5 bottles per lot HK\$75,000-130,000

Lot 5233

清蒸東星斑配 Ramonet Montrachet

東星斑色彩鮮豔，身上佈滿白色的花斑，形似繁星滿天，故而稱「星斑」。「東」字則來源於其產地，東沙群島。東星斑的外皮光滑且肉色雪白，多用來清蒸。紅皮白肉

比之下，賣相極佳。東星斑生性兇猛，會吃掉任何能吃掉的魚、蝦等物，因此生猛好動，故而肉質細嫩。東星斑美味且價格不菲，是宴會必備的經典菜式之一。東星斑烹飪方法有若干種，但當屬清蒸能最大程度保留其原汁原味，使人充分享受其鮮嫩口感。清蒸做法相當簡單，但非久經考驗的大廚不能為之。因為清蒸要求廚師

火候的掌握能力極高，烹飪時間略短則肉夾生，略長則肉已過老，喪失其鮮嫩口感。做好的清蒸東星斑，肉質鮮嫩，湯汁風味十足，入口極富層次感。勃艮第金丘地區出產的霞多麗，香氣複雜，是搭配東星斑非常不錯的選擇。也可以選配同樣由霞多麗釀造的白中白香檳，怡人的酸度和豐盈的氣泡，與東星斑的肉質和湯汁均能很好的融合在一起。

張儵翰，丙申年初。

Armand Rousseau, Chambertin-Clos-de-Bèze 1996

Grand Cru, Côte de Nuits

Two very slightly stained and two very slightly damaged labels. Levels 1cm

5237 5 bottles *per lot* HK\$45,000-75,000

Armand Rousseau, Chambertin-Clos-de-Bèze 2005

Grand Cru, Côte de Nuits

Very slightly damaged labels. US import slip labels

5238 6 bottles *per lot* HK\$70,000-120,000

Armand Rousseau, Gevrey-Chambertin Clos Saint-Jacques 2006

1er Cru, Côte de Nuits

Three signs of old seepage. Three slightly stained labels

5239 6 bottles *per lot* HK\$16,000-26,000

Mixed Armand Rousseau 1988 & 1999

1988 Armand Rousseau, Gevrey-Chambertin Clos Saint-Jacques (3)

One sign of seepage. Good appearance. Levels 1cm

1999 Armand Rousseau, Gevrey-Chambertin Clos Saint-Jacques (4)

Two slightly damaged labels. US import slip labels

5240 Above 7 bottles *per lot* HK\$32,000-55,000

Mixed Armand Rousseau 1990

1990 Armand Rousseau, Gevrey-Chambertin Clos Saint-Jacques (4)

Two very slightly stained and one very slightly damaged labels. Levels 1cm or better

1990 Armand Rousseau, Ruchottes-Chambertin Clos des Ruchottes (6)

Very slightly damaged labels. Levels 1cm or better

5241 Above 10 bottles *per lot* HK\$70,000-120,000

Bouchard Père & Fils, La Romanée 2002

Grand Cru, Côte de Nuits

Two very slightly stained labels

5242 12 bottles *per lot* HK\$75,000-120,000

Christophe Roumier, Ruchottes-Chambertin 2004

Grand Cru, Côte de Nuits

5243 14 bottles *per lot* HK\$20,000-32,000

Domaine Comte Georges de Vogüé, Musigny Vieilles Vignes 1947

Grand Cru, Côte de Nuits

One corroded and damaged capsule. Two protruding corks. Two slightly stained and slightly damaged labels.

One damaged label. Levels one 3cms, one 4cms and one 6cms

5244 3 bottles *per lot* HK\$45,000-90,000

5245 NO LOT

Domaine Comte Georges de Vogüé, Musigny Vieilles Vignes 2005

Grand Cru, Côte de Nuits

Two stained and four very slightly damaged labels. US import slip labels, one stained and one slightly damaged

5246 7 bottles *per lot* HK\$45,000-75,000



Lot 5242

Lots 5244-5248

木須肉配 de Vogüé Musigny

木須肉是一道家常菜，發源于魯菜，傳遍大江南北，也常被寫作苜蓿肉，但其實原名木樨肉，記載于清梁恭辰的《北東園筆錄》：「北方店中以雞子炒肉，名木樨肉，蓋取其有碎黃色也」。樨是一種開白色或黃色小花的灌木，代指雞蛋。根據記錄，木須肉最早出現于孔府菜的功能表上，最初的原料是豬肉、雞蛋、木耳和玉蘭片（筍片），傳入北京地區後因為當地缺乏竹筍，因此往往用胡蘿蔔、黃瓜代之，這也造成了今日的木須肉名稱寫法多樣、原料各異的局面，但一定都會使用豬肉、木耳和雞蛋來烹製。勃艮第傳統貴族名莊 de Vogue，釀制最頂級的木樨尼特級白葡萄酒，細膩的單寧很好的搭配和可口的肉片、順滑的木耳和鮮嫩的雞蛋，是非常好的搭配。

乙未秋日，張翰翰。

Sautéed Sliced Pork, Eggs and Black Fungus (Moo shu pork) and de Vogüé Musigny

Sautéed sliced pork, eggs and black fungus (Moo shu prok) is a typical homemade dish. Originated from Shandong, variations are seen all over China and are interpreted as different names. Its initial form was depicted by Qing Dynasty writer, Liang Gongchen, in his 'Notes from the Northeast Garden' (*Beidong Yuan Bilu*): "Northern restaurants stir-fry eggs with pork, calling it *mu xi rou*, for its yellow colour." Noted by Liang, the 'xi' refers to bushes with white and yellow flowers, and is an allusion to egg pieces. The earliest form of the dish in record was included in the menu of a Confucian banquet. Original ingredients included pork, eggs, black mushrooms and slices of bamboo shoots. When the dish became popular later in Beijing, carrot and cucumber slices are used to replace bamboo shoots as they are scarce in the city. All these contribute to the development of the myriad versions of this famous dish, however the key ingredients of pork, black mushrooms and eggs remain present in all interpretations. The distinguished Domaine Comte de Vogüé makes the finest Grand Cru Musigny. Classy and tannic, the Musigny pairs greatly with the flavourful taste of the meat, the refreshing texture of the mushrooms and the softness of the eggs.

Autumn 2015. Austin Zhang

Mixed Domaine Comte Georges de Vogüé, Musigny Vieilles Vignes 1952, 1964, 1966 & 1976

1952 Domaine Comte Georges de Vogüé, Musigny Vieilles Vignes (1)

Cut capsule, vintage and branded cork just visible. Stained and damaged label. Level 4.5cms

1964 Domaine Comte Georges de Vogüé, Musigny Vieilles Vignes (1)

Slightly stained label. Level 4.5cms

1966 Domaine Comte Georges de Vogüé, Musigny Vieilles Vignes (1)

Corroded capsule. Damaged label. Level 4cms

1976 Domaine Comte Georges de Vogüé, Musigny Vieilles Vignes (1)

Slightly depressed cork. German import slip neck and back labels. Slightly stained label. Level 2.5cms

5247 Above 4 bottles per lot HK\$35,000-60,000

Mixed Domaine Comte Georges de Vogüé, Musigny Vieilles Vignes 1990, 1993 & 1999

1990 Domaine Comte Georges de Vogüé, Musigny Vieilles Vignes (4)

Integrated US import labels. Three very slightly stained and three very slightly damaged labels. Levels one 0.5cm and three 1.5cms

1993 Domaine Comte Georges de Vogüé, Musigny Vieilles Vignes (1)

Very slightly stained integrated US label. Level 3cms

1999 Domaine Comte Georges de Vogüé, Musigny Vieilles Vignes (1)

Very slightly stained and damaged label

5248 Above 6 bottles per lot HK\$35,000-55,000

Domaine Comte Georges de Vogüé, Chambolle-Musigny Les Amoureuses 1971

1er Cru, Côte de Nuits

Slightly depressed corks. Stained labels. US import slip labels. Levels one 3cms and one 3.5cms

5249 2 bottles per lot HK\$24,000-42,000

Mixed Domaine Comte Georges de Vogüé, Chambolle-Musigny Les Amoureuses 1996 & 2004

1996 Domaine Comte Georges de Vogüé, Chambolle-Musigny Les Amoureuses (3)

Very slightly stained and very slightly damaged labels. Levels 0.5cm

2004 Domaine Comte Georges de Vogüé, Chambolle-Musigny Les Amoureuses (2)

5250 Above 5 bottles per lot HK\$12,000-20,000

Comte Georges de Vogüe, Musigny 1945*Grand Cru, Côte de Nuits**Labels state "Mis en bouteilles par Mr. J. Drouhin, Négociant à Beaune". Protruding cork. Stained label. Level 5.5cms*5251 1 bottle *per lot* HK\$15,000-30,000**Comte Georges de Vogüe, Musigny 1947***Grand Cru, Côte de Nuits**Labels state "Mis en bouteilles par Mr. J. Drouhin, Négociant à Beaune". One cut capsule, no cork branding. One sign of old seepage. Stained labels, one slightly damaged. Levels one 1.5cms, one 2cms, two 2.5cms, two 3.5cms, one 4.5cms*5252 7 bottles *per lot* HK\$140,000-260,000**Comte Georges de Vogüe, Musigny 1949***Grand Cru, Côte de Nuits**Labels state "Mis en bouteilles par Mr. J. Drouhin, Négociant à Beaune". Stained labels. Levels one 1.5cms and one 3.5cms*5253 2 bottles *per lot* HK\$35,000-60,000**Domaine du Comte Liger-Belair, La Romanée 2010***Grand Cru, Côte de Nuits**One stained, three slightly damaged and one damaged labels. US import slip labels*5254 11 bottles *per lot* HK\$240,000-380,000

5255 NO LOT

DOMAINE DE LA ROMANÉE-CONTI

Domaine de la Romanée-Conti often abbreviated to DRC, is widely considered among the world's greatest wine producers, and DRC bottles are among the worlds' most expensive. It takes its name from the Domaine's most famous vineyard, Romanée-Conti. This vineyard, just under 2 hectares, was coveted by a famous collector of jewelry, Madame de Pompadour, but she was out-bid by the Prince de Conti, hence the name. In 1868 the vineyard passed to the de Villaine family and is still, today, managed by Aubert de Villaine assisted by Henri-Frédéric Roch.

The Domaine owns almost 28 hectares of vineyards and this includes sole ownership of the 1.81 hectares

of Romanée-Conti Grand Cru and the entire 6.06 hectares of La Tâche. They also own holdings of 3.51 hectares of Richebourg, 5.29 hectares of Romanée-Saint-Vivant, 3.53 hectares of Grands-Echézeaux, 4.67 hectares of Echézeaux and 0.68 hectares of Le Montrachet. Occasionally the Domaine produces a Vosne-Romanée Premier Cru Cuvée Duvault-Blochot from younger vines in their Grand Cru vineyards. The Domaine has also started producing Corton from the 2009 vintage after they leased 2.28 hectares of the vineyards that includes parcels in Corton Clos du Roi, Bressandes and Renardes. The Domaine has been at the forefront of viticultural developments and have adopted the biodynamic approach. The Domaine uses vine material from their Romanée-Conti vineyard for their other vineyards. Nicolas Jacob and his team work in the vineyard

The Domaine rarely uses de-stemming and following a strict sorting to eliminate any sub-standard fruit, the must is cold-macerated for approximately six days prior to fermentation at temperatures up to a maximum of 34 degrees. The wines are matured in entirely new oak. The white grapes from Le Montrachet are often picked relatively late which results in forward, opulent and expressive wines, but they are perfectly balanced with refreshing acidity.

There is no disputing the quality of the wines, particularly their high-sought after and prized Romanée-Conti which is very scarce as only approximately 500 cases are produced each vintage, perhaps much less. As Michael Broadbent M.V. stated "It never fails to astonish me that the strips of vines which stretch only a modest number of meters up the very gentle slopes from the outskirts of an equally modest, indeed remarkably rural rambling of village Vosne, are capable of producing wines of such world class quality". This wine needs time and evolves incredible complexity with bottle-age.

La Tâche, which tends to be slightly more approachable, fragrant, lush, silky-textured, but has the same intensity, depth and concentration of the Romanée-Conti is also a very highly sought-after wine and some consider this to be the greatest red wine from Burgundy. Romanée-Saint-Vivant is very elegant and poised, whereas Richebourg is more robust and tannic, with deeper colour than the Romanée St Vivant. The Grands-Echézeaux is generally lush and outperforms the Echézeaux, although in some vintages this is reversed.

Le Montrachet is also a highly-sought after wine as the production is miniscule; in 2008 only 3524 bottles were produced and in 2002 this figure was down to 2321. Opulent and rich with concentration, depth, and powerful flavours yet with elegance and poise; a sumptuous wine!

Domaine de la Romanée-Conti, Romanée-Conti 1980*Grand Cru, Côte de Nuits**Slightly stained vintage neck label and front label. Slightly damaged label. Leroy slip label. Level 2cms*5256 1 bottle *per lot* HK\$65,000-100,000

Domaine de la Romanée-Conti, Romanée-Conti 1985

*Grand Cru, Côte de Nuits
One corroded capsule, one cut capsule to reveal
branded cork. One slightly damaged neck label. Leroy
slip labels, one slightly damaged. Slightly stained
labels. Levels one 2.5cms and one 3.5cms*

5257 2 bottles per lot HK\$160,000-260,000

Domaine de la Romanée-Conti, Romanée-Conti 1990

*Grand Cru, Côte de Nuits
Two cut capsules to reveal fully branded corks. Wilson
Daniels import back labels. Levels 1.5cms or better*

5258 4 bottles per lot HK\$400,000-650,000

Domaine de la Romanée-Conti, Romanée-Conti 1996

*Grand Cru, Côte de Nuits
Two very slightly stained and one slightly damaged
labels. Two very slightly damaged vintage neck labels.
Two Japanese and one US import slip labels. Levels one
1cm and two 1.5cms*

5259 3 bottles per lot HK\$240,000-400,000

Domaine de la Romanée-Conti, Romanée-Conti 1997

*Grand Cru, Côte de Nuits
Very slight signs of old seepage. One very slightly
damaged back label. One very slightly stained label.
Levels 1.5cms*

5260 2 bottles per lot HK\$140,000-220,000

Domaine de la Romanée-Conti, Romanée-Conti 1998

*Grand Cru, Côte de Nuits
One very slightly damaged label. One slightly damaged
back label and one slightly stained Wilson Daniels
import back label. Levels 0.5cm*

5261 2 bottles per lot HK\$140,000-220,000

Domaine de la Romanée-Conti, Romanée-Conti 1999

*Grand Cru, Côte de Nuits
Very slightly stained labels, one slightly damaged.
Wilson Daniels back labels*

5262 2 bottles per lot HK\$180,000-300,000

Domaine de la Romanée-Conti, Romanée-Conti 2001

*Grand Cru, Côte de Nuits
Very slightly stained labels, one slightly damaged.
Slightly stained back labels*

5263 2 bottles per lot HK\$140,000-220,000

Domaine de la Romanée-Conti, Romanée-Conti 2006

*Grand Cru, Côte de Nuits
Slightly stained labels. Slightly stained Wilson Daniels
import back labels*

5264 2 bottles per lot HK\$130,000-220,000

Domaine de la Romanée-Conti, Romanée-Conti 2006

*Grand Cru, Côte de Nuits
One slightly stained label. Wilson Daniels import back
labels*

5265 3 bottles per lot HK\$200,000-320,000

Domaine de la Romanée-Conti, Romanée-Conti 2011

*Grand Cru, Côte de Nuits
Very slightly stained label. HK import back label*

5266 1 bottle per lot HK\$65,000-110,000

Domaine de la Romanée-Conti, Romanée-Conti 2012

*Grand Cru, Côte de Nuits
One sign of old seepage. HK import back labels*

5267 2 bottles per lot HK\$150,000-240,000



HERRE
1700
FET A BUI PAR DE FATH
ILLES GAUDIN DE VILLA
VE - LERGY - LE 10
CET TE GROSSA
LE 10 - 1700
METTE CHAUDRON
ET BRIGNOT CAP

Mixed DRC Romanée-Conti 1991 & 1992

1991 Domaine de la Romanée-Conti, Romanée-Conti (1)
Very slightly stained label. Slightly damaged Wilson Daniels import back label. Level 1.5cms

1992 Domaine de la Romanée-Conti, Romanée-Conti (1)
Very slightly damaged label. Slightly damaged Wilson Daniels import back label. Level 2cms

5268 Above 2 bottles *per lot* HK\$150,000-260,000

Mixed DRC Romanée-Conti 1993 & 1994

1993 Domaine de la Romanée-Conti, Romanée-Conti (1)
Very slightly stained label. Wilson Daniels back label. Level 3cms

1994 Domaine de la Romanée-Conti, Romanée-Conti (1)
Very slightly stained and slightly damaged label. Wilson Daniels back label. Level 1.2cms

5269 Above 2 bottles *per lot* HK\$140,000-240,000

Mixed DRC Romanée-Conti 1995 & 1996

1995 Domaine de la Romanée-Conti, Romanée-Conti (1)
Wilson Daniels import back label. Very slightly stained label. Level 2.5cms

1996 Domaine de la Romanée-Conti, Romanée-Conti (1)
Slightly stained label. HK import back label. Level 1cm

5270 Above 2 bottles *per lot* HK\$150,000-260,000

Mixed DRC Romanée-Conti 1997 & 1998

1997 Domaine de la Romanée-Conti, Romanée-Conti (1)
1998 Domaine de la Romanée-Conti, Romanée-Conti (1)

Both stained vintage neck labels and front labels. Slightly damaged back labels. Levels 1cm

5271 Above 2 bottles *per lot* HK\$140,000-240,000

Mixed DRC Romanée-Conti 2000 & 2001

2000 Domaine de la Romanée-Conti, Romanée-Conti (1)
2001 Domaine de la Romanée-Conti, Romanée-Conti (1)

Both Wilson Daniels import back labels. Very slightly stained labels

5272 Above 2 bottles *per lot* HK\$150,000-260,000

Mixed DRC Romanée-Conti 2002 & 2004

2002 Domaine de la Romanée-Conti, Romanée-Conti (1)
Very slightly stained label. Slightly stained Wilson Daniels back label

2004 Domaine de la Romanée-Conti, Romanée-Conti (1)
Very slightly stained label. Slightly stained back label

5273 Above 2 bottles *per lot* HK\$140,000-240,000

Domaine de la Romanée-Conti, La Tâche 1978

*Grand Cru, Côte de Nuits
 Two damaged and cut capsules to reveal branded corks. One sign of old seepage. One damaged vintage neck label. Slightly stained and slightly damaged Leroy slip labels. One slightly stained, one stained and slightly damaged labels. Two US import slip labels. Levels 3cms*

5274 3 bottles *per lot* HK\$95,000-160,000

Domaine de la Romanée-Conti, La Tâche 1985

*Grand Cru, Côte de Nuits
 Three corroded and one damaged capsules. One slight sign of old seepage. One slightly damaged vintage neck label. One stained and three slightly stained labels. One Leroy and six Wilson Daniels slip labels. Levels one 1.5cms, two 2cms, one 2.5cms, two 3cms, one 3.5cms and one 4cms*

5275 8 bottles *per lot* HK\$150,000-280,000

Domaine de la Romanée-Conti, La Tâche 1990

*Grand Cru, Côte de Nuits
 Five signs of seepage. Six slightly depressed corks. One stained vintage neck label. One stained, three slightly stained and one slightly damaged labels. Nine Wilson Daniels import back labels, four damaged. Levels five 1.5cms, three 2cms, one 2.5cms and one 3.5cms*

5276 10 bottles *per lot* HK\$320,000-500,000

Domaine de la Romanée-Conti, La Tâche 1993

*Grand Cru, Côte de Nuits
 Eight US import slip labels, two damaged Wilson Daniels import back labels. Three slightly damaged labels. Levels two 1cm, three 1.5cms, one 2cms, three 2.5cms and one 3cms*

5277 10 bottles *per lot* HK\$160,000-260,000

Domaine de la Romanée-Conti, La Tâche 1999*Grand Cru, Côte de Nuits**One sign of old seepage. One wine stained vintage neck label. One damaged and four slightly stained labels. Seven Wilson Daniels and one HK import back labels. Levels nine 1cm or better and one 1.5cms*5278 10 bottles *per lot* HK\$280,000-450,000**Domaine de la Romanée-Conti, La Tâche 2004***Grand Cru, Côte de Nuits**Two signs of old seepage. One slightly damaged and one slightly stained vintage neck labels. Three slightly stained labels. Six Wilson Daniels and two slightly damaged HK import back labels*5279 8 bottles *per lot* HK\$100,000-160,000**Domaine de la Romanée-Conti, La Tâche 2005***Grand Cru, Côte de Nuits**Wilson Daniels import back labels. Four very slightly damaged vintage neck labels. Very slightly stained labels, one very slightly damaged*5280 11 bottles *per lot* HK\$260,000-450,000**Mixed DRC La Tâche 1990 & 2003 in Magnum****1990 Domaine de la Romanée-Conti, La Tâche**

magnum (1)

*Very slightly damaged capsule. Slightly stained label. Stained and slightly damaged back label. US import slip label. Level 2cms***2003 Domaine de la Romanée-Conti, La Tâche**

magnum (1)

*Very slightly damaged capsule. Slightly depressed cork. Slightly stained and slightly damaged label. Damaged back label. Level 2.5cms*5281 Above 2 magnums *per lot* HK\$95,000-150,000**Mixed DRC La Tâche 1991, 1992, 1995 & 1996****1991 Domaine de la Romanée-Conti, La Tâche** (3)*Slight sign of old seepage. One very slightly stained label. Wilson Daniels import back labels. Levels one 1.5cms, one 2cms and one 2.5cms***1992 Domaine de la Romanée-Conti, La Tâche** (3)*One sign of old seepage. One slightly protruding cork. Two very slightly stained labels. Wilson Daniels import back labels. Levels one 2cms and two 2.5cms***1995 Domaine de la Romanée-Conti, La Tâche** (3)*Wilson Daniels import back labels. Slightly damaged labels. Levels one 0.5cm, one 1.5cms and one 2cms***1996 Domaine de la Romanée-Conti, La Tâche** (3)*One slightly stained label. One US import slip label. Levels two 1cm and one 1.5cms*5282 Above 12 bottles *per lot* HK\$180,000-300,000**Mixed DRC La Tâche 1994, 1995 & 1996****1994 Domaine de la Romanée-Conti, La Tâche** (1)*Wilson Daniels import back label. Level 1cm***1995 Domaine de la Romanée-Conti, La Tâche** (7)*Wilson Daniels import back labels. Four slightly damaged labels. Levels five 1.5cms and two 2.5cms***1996 Domaine de la Romanée-Conti, La Tâche** (4)*Two HK import back labels and two US import slip labels. Levels one 0.5cm, two 1cms and one 1.5cms*5283 Above 12 bottles *per lot* HK\$170,000-280,000**Mixed DRC La Tâche 1997 & 1998****1997 Domaine de la Romanée-Conti, La Tâche** (9)*Two very slightly damaged labels. Levels two 1cms, four 1.5cms, two 2cms and one 3cms***1998 Domaine de la Romanée-Conti, La Tâche** (2)*One slightly damaged labels. One Wilson Daniels back label. Levels 0.5cm*5284 Above 11 bottles *per lot* HK\$140,000-240,000**Mixed DRC La Tâche 2000, 2001 & 2006****2000 Domaine de la Romanée-Conti, La Tâche** (3)*Wilson Daniels import back labels***2001 Domaine de la Romanée-Conti, La Tâche** (3)*Wilson Daniels import back labels***2006 Domaine de la Romanée-Conti, La Tâche** (6)*Wilson Daniels import back labels. One stained label*5285 Above 12 bottles *per lot* HK\$170,000-280,000

Mixed DRC La Tâche 2011 & 2012

2011 Domaine de la Romanée-Conti, La Tâche (3)

Two very slightly stained labels. HK import back labels, one very slightly damaged

2012 Domaine de la Romanée-Conti, La Tâche (6)

One sign of old seepage. One very slightly damaged label. HK import back labels

5286 Above 9 bottles per lot HK\$130,000-220,000

Domaine de la Romanée-Conti, Richebourg 1969

Grand Cru, Côte de Nuits

Corroded capsules. Slightly damaged Leroy slip labels. Stained and slightly damaged labels. Levels one 3cms and 4cms

5287 2 bottles per lot HK\$20,000-35,000

Domaine de la Romanée-Conti, Richebourg 1971

Grand Cru, Côte de Nuits

One cut capsule to reveal fully branded cork. Slightly corroded capsules. Green roundels on very slightly stained labels. Levels one 2cms and four 2.5cms

5288 5 bottles per lot HK\$130,000-200,000

Domaine de la Romanée-Conti, Richebourg 1987

Grand Cru, Côte de Nuits

Leroy slip labels. Levels three 1.5cms, one 2cms, two 2.5cms and one 3cms

5289 7 bottles per lot HK\$45,000-75,000

Domaine de la Romanée-Conti, Richebourg 2004

Grand Cru, Côte de Nuits

Three slightly stained labels. Some slightly stained Wilson Daniels import back labels

5290 10 bottles per lot HK\$80,000-130,000

Mixed DRC Richebourg 1974 & 1983

1974 Domaine de la Romanée-Conti, Richebourg (1)

Very slightly depressed cork. Japanese import slip label. Badly stained and very slightly damaged label. Level 3cms

1983 Domaine de la Romanée-Conti, Richebourg (1)

Very slightly damaged capsule. Damaged Leroy slip label. Stained and very slightly damaged label. Level 2.5cms

5291 Above 2 bottles per lot HK\$14,000-24,000

Mixed Formats of DRC Richebourg

1990 Domaine de la Romanée-Conti, Richebourg (3)

One slightly stained and slightly damaged labels. Two Wilson Daniels import back labels. Levels two 1.5cms and one 2.5cms

1991 Domaine de la Romanée-Conti, Richebourg (1)

Very slightly damaged capsule. Slightly damaged label. Wilson Daniels import back label. Level 1.5cms

1992 Domaine de la Romanée-Conti, Richebourg (1)

Very slightly damaged capsule. Slightly stained and very slightly damaged label. Wilson Daniels import back label. Level 2.5cms

1999 Domaine de la Romanée-Conti, Richebourg (1)

Very slightly stained label. HK import back label

2003 Domaine de la Romanée-Conti, Richebourg magnum (1)

Damaged and slightly stained label

5292 Above 1 magnum and 6 bottles per lot HK\$110,000-180,000

Mixed DRC Richebourg 1993 & 1994

1993 Domaine de la Romanée-Conti, Richebourg (3)

One corroded capsule. One slightly protruding cork. One sign of old seepage. One slightly stained and slightly damaged labels. Two Wilson Daniels import back labels. Levels one 2cms, one 2.5cms and one 3cms

1994 Domaine de la Romanée-Conti, Richebourg (8)

Three signs of old seepage. Slightly damaged labels. Slightly damaged back labels. Two Wilson Daniels import back labels. Levels two 1cm, four 1.5cms and two 2cms

5293 Above 11 bottles per lot HK\$85,000-130,000

Mixed DRC Richebourg 1995 & 1996

1995 Domaine de la Romanée-Conti, Richebourg (2)

One sign of old seepage. One US import slip label on capsule. One slightly damaged label. One slightly damaged back label. Levels one 1.5cms and one 3.5cms

1996 Domaine de la Romanée-Conti, Richebourg (3)

US import slip labels. Levels 1cm

5294 Above 5 bottles per lot HK\$48,000-80,000

Mixed DRC Richebourg 1997 & 1998

1997 Domaine de la Romanée-Conti, Richebourg (4)

Two very slightly stained and one slightly damaged labels. Levels three 1cm and one 2.5cms

1998 Domaine de la Romanée-Conti, Richebourg (4)

Very slightly stained labels. One slightly damaged label. Two Wilson Daniels import back labels

5295 Above 8 bottles per lot HK\$65,000-100,000

Mixed DRC Richebourg 2000, 2001 & 2005

2000 Domaine de la Romanée-Conti, Richebourg (2)
Wilson Daniels import back labels. Very slightly stained labels. Levels one 0.5cm and one 1.5cms

2001 Domaine de la Romanée-Conti, Richebourg (2)
Wilson Daniels import back labels

2005 Domaine de la Romanée-Conti, Richebourg (4)
Very slightly stained and one very slightly damaged labels. Wilson Daniels import back labels

5296 Above 8 bottles *per lot* HK\$90,000-150,000

Lots 5301-5303

番茄燉牛腩 DRC Echézeaux

番茄燉牛腩可謂經典，但是很難確認其菜系譜系。番茄牛腩原料常見易得，烹飪過程也並不複雜，但做的好卻很難，因為這道菜最重要的就是時間與耐心。牛肉要經過長時間的文火慢燉才能入味，而番茄也需要時間才能把最精華的部分滿滿的轉移到湯中。做好的番茄燉牛腩，不但牛肉味道豐富且富有嚼勁，而且湯汁濃郁並且酸甜可口，令人欲罷不能。搭配勃艮第的王者羅曼尼康帝酒園出產的依瑟索相當不錯。雖然 Echezeaux 是目前 DRC 所有特級田中價格最親民的一塊，但是水準和品質完全對得起 DRC 幾百年的聲望，其柔和的酸度恰好搭配濃郁的番茄汁，柔順的單甯也與小火慢燉的牛肉堪為絕配，時而隱現的薄荷氣息更是增添了額外的層次感。

乙未秋日，張儵翰。

Stewed Beef Brisket with Tomato and DRC Echézeaux

Stewed beef brisket with tomato is a timeless dish with an unknown origin. Tomatoes and beef briskets are both very common ingredients. The cooking process is simple. This dish is, however, difficult to master, as it requires a lot of time, attention and patience. The briskets must be slow-cooked in low heat over a long period of time to lock the juices and flavours, whereas the tomatoes take time to imbue the stock with their aroma. Well-cooked stewed beef brisket is hearty with an intense meaty flavour, together with the irresistible sauce that is extremely rich, creates a perfect harmony between tanginess and sweetness. The dish can be nicely paired with an Echézeaux by the king of Burgundy, Domaine de La Romanée-Conti. Despite being one of the most affordable DRC Grand Crus, the Echézeaux boasts a quality deserving the centuries of prestige of DRC. Its gentle acidity is splendid with the rich tomato sauce, and the smooth tannins set off the slow-cooked beef briskets perfectly. The faint mint taste also adds extra sense of depth to the flavour.

Autumn 2015. Austin Zhang

Mixed DRC Richebourg 2011 & 2012

2011 Domaine de la Romanée-Conti, Richebourg (2)
One very slightly stained label. HK import back labels

2012 Domaine de la Romanée-Conti, Richebourg (4)
One very slightly stained label. HK import back labels

5297 Above 6 bottles *per lot* HK\$55,000-95,000

Domaine de la Romanée-Conti, Romanée-Saint-Vivant 1989

*Grand Cru, Côte de Nuits
Good appearance*

5298 2 magnums *per lot* HK\$26,000-45,000

Domaine de la Romanée-Conti, Romanée-Saint-Vivant 2005

*Grand Cru, Côte de Nuits
One very slightly protruding cork. Slightly stained and slightly damaged labels. Stained and slightly damaged back labels*

5299 3 bottles *per lot* HK\$28,000-48,000

Mixed DRC Romanée-Saint-Vivant 2011 & 2012

2011 Domaine de la Romanée-Conti, Romanée-Saint-Vivant (2)
Signs of old seepage. Very slightly stained labels. HK import back labels

2012 Domaine de la Romanée-Conti, Romanée-Saint-Vivant (4)
HK import back labels

5300 Above 6 bottles *per lot* HK\$50,000-80,000

Mixed DRC Echézeaux & Grands-Echézeaux 1971 & 1976

1971 Domaine de la Romanée-Conti, Echézeaux (2)
J.L.P Lebegue slip labels. Levels 2cms

1971 Domaine de la Romanée-Conti, Grands-Echézeaux (2)
One slightly depressed cork. Leroy slip labels. One US import slip label. Stained labels. Levels one 3cms and one 4cms

1976 Domaine de la Romanée-Conti, Grands-Echézeaux (2)
Leroy slip labels. Slightly stained labels. Levels one 1cm and one 1.5cms

5301 Above 6 bottles *per lot* HK\$60,000-110,000

Mixed DRC Echézeaux & Grands-Echézeaux 2011**2011 Domaine de la Romanée-Conti, Echézeaux (2)***Very slightly damaged labels. HK import back labels***2011 Domaine de la Romanée-Conti, Grands-Echézeaux (2)***One sign of old seepage. One very slightly damaged label. HK import back labels*

5302 Above 4 bottles per lot HK\$28,000-45,000

Lot 5308

北菇滑雞煲仔飯配 Georges Roumier Bonnes-Mares

煲仔飯傳遍大江南北的粵菜，風味多達百餘種，常見的如臘味、豉汁排骨、北菇滑雞。烹飪做法簡單，耗時略長，將淘洗好的大米放入瓦罐中，蒸至七成熟後加入調味的肉類等配料，再轉用文火慢慢煲熟。北菇滑雞選取個頭大的冬菇切塊，配合鮮嫩的雞胸肉，非常入味，煲仔附近的米飯往往會燒成鍋巴，與糯香的米飯形成對比鮮明的口感。勃艮第傳奇酒莊 George Roumier 釀造的特級田 Bonnes Mares，如同天鵝絨手套中的鐵拳，單甯絲滑柔順卻強勁有力，強大而有氣場的紅色水果和花香，讓人忘之不能，與滑嫩的雞肉和冬菇搭配最棒。

乙未秋日，張儵翰。

Clay Pot Rice with Chicken and Shiitake Mushrooms and Georges Roumier Bonnes-Mares

Clay pot rice is a widely spread Cantonese dish all over the country. Clay pot rice comes with various styles, with steamed cured meat, spare ribs in black bean sauce or chicken with shiitake mushrooms become the most popular combinations. The cooking process is simple but time-consuming. Thoroughly washed rice is placed in a clay pot and steamed. Before the rice is fully cooked, seasoned meat or other garnish are then put on top and slowly cooked over low heat till done. Large-sized shiitake mushrooms are sliced to accompany fresh chicken breast, and each ingredient imbibes the savour of the others. A crispy rice crust often forms at the bottom of the pot, providing a contrasting texture with the soft and fluffy rice in the middle. Grand Cru Bonnes-Mares of the legendary Burgundy Domaine George Roumier acts like an iron fist beneath a pair of velvet gloves — its tannins are silky and delicate with a packed outstanding power. A fresh mix of red berries and floral scents makes this wine unforgettable. It pairs wonderfully with the succulent chicken and the intense taste of the mushrooms.

Autumn 2015. Austin Zhang

Mixed DRC Echézeaux & Grands-Echézeaux 2012**2012 Domaine de la Romanée-Conti, Echézeaux (4)***Two signs of old seepage. Two very slightly damaged**HK import back labels***2012 Domaine de la Romanée-Conti, Grands-Echézeaux (4)***One sign of old seepage. HK import back labels*

5303 Above 8 bottles per lot HK\$55,000-100,000

Domaine Dujac, Clos de la Roche 1990*Grand Cru, Côte de Nuits**Two slightly depressed corks. Three very slightly damaged labels. US import slip labels. Levels three 1.5cms or better and three 2cms*

5304 6 bottles per lot HK\$110,000-180,000

Domaine Dujac, Clos Saint-Denis 1990*Grand Cru, Côte de Nuits**US import slip labels. Levels one 1.5cms and two 2cms*

5305 3 bottles per lot HK\$55,000-90,000

Domaine Faiveley, Chambertin-Clos-de-Bèze 1990*Grand Cru, Côte de Nuits**One sign of old seepage. Two very slightly stained vintage neck labels. Three very slightly damaged labels. Levels two 1.5cms, two 2cms and two 2.5cms*

5306 6 bottles per lot HK\$8,500-14,000

Domaine François Lamarche, La Grande Rue 2009*Grand Cru Monopole, Côte de Nuits**One slightly damaged label*

5307 10 bottles per lot HK\$22,000-38,000

Domaine Georges Roumier, Bonnes-Mares 1985*Grand Cru, Côte de Nuits**Damaged capsules, one cut to reveal fully branded cork. Stained and two slightly damaged vintage labels. One badly stained, three stained and one badly damaged labels. Levels one 4cms, one 4.5cms and two 5cms*

5308 4 magnums per lot HK\$100,000-200,000

Domaine Georges Roumier, Musigny 1985*Grand Cru, Côte de Nuits**One cut capsule to reveal branded cork. Slight signs of old seepage. One stained and one badly stained labels. Levels one 1.5cms and one 3cms*

5309 2 bottles per lot HK\$65,000-100,000

Domaine Georges Roumier, Musigny 1990

Grand Cru, Côte de Nuits

One damaged capsule cut to reveal branded cork. One Château & Estate neck label. Two stained and damaged vintage neck labels and front labels. Levels two 1cm and one 1.5cms

5310 3 bottles per lot HK\$100,000-160,000

Domaine Georges Roumier, Chambolle-Musigny Les Amoureuses 1985

1er Cru, Côte de Nuits

Slightly depressed corks. Slightly stained vintage neck labels, one slightly damaged. Slightly stained labels. Levels one 1cm, one 2.5cms and one 3cms

5311 3 bottles per lot HK\$65,000-110,000

Domaine Georges Roumier, Chambolle-Musigny Les Amoureuses 2004

1er Cru, Côte de Nuits

One sign of old seepage. Very slightly damaged labels

5312 3 magnums per lot HK\$26,000-45,000

Mixed Domaine Georges Roumier, Bonnes-Mares 1999 & 2004

1999 Domaine Georges Roumier, Bonnes-Mares (1)

Very slightly stained and very slightly damaged label

2004 Domaine Georges Roumier, Bonnes-Mares (13)

One very slightly stained label. Six US import back labels

5313 Above 14 bottles per lot HK\$45,000-75,000

HENRI JAYER

Henri Jayer was born on February 2nd 1922 third son of Eugène Jayer. He married Marcelle Rouget in 1942. He attended the University of Dijon in the 1940's and earned a degree in oenology. Henri Jayer is still regarded as one of the most influential winemakers in Burgundy and his legacy continues to inspire many winemakers around the globe. Officially Henri Jayer retired in 1987 and his nephew Emmanuel Rouget became involved in the Domaine. However Henri continued to play an active role in the wine making and carried on bottling half the production under his own name and the other half was bottled under Emmanuel Rouget's name. Henri Jayer's last vintage was in 2001. Since Henri Jayer's retirement in 2001 the vineyards have been tended by Emmanuel Rouget. Sadly, Henri Jayer died on 20th September 2006; however his work continues to inspire many young Burgundy growers.

Jayer was a pioneer and firmly believed that care in the vineyard was fundamental to producing fine Burgundy. Treatments were kept to a minimum and



Lot 5304

there was a rigorous selection of grapes eliminating any sub-standard fruit. Yields were kept very low. Wines produced from his small 6.30 hectare Domaine, based in and around Vosne-Romanée are arguably some of the finest wines ever produced in Burgundy, including the legendary Richebourg, Echézeaux, and Cros Parantoux. The Domaine included holdings in Echézeaux, Richebourg and also vineyards in three Premier Cru sites Les Brûlées, Les Beaumonts and Cros Parantoux in Vosne-Romanée.

Total de-stemming was used. A pre-fermentation cold maceration by reducing the vat temperature to 15 degrees for four or five days was used to extract additional colour and flavours. Only natural yeasts were used for the fermentation which added complexity and individuality to the wines. The majority of the wines were aged in new Tronçais oak barrels. As few rackings as possible and no filtration ensured that all of the subtle nuances, complexity and concentration were preserved. Henri Jayer wines are superbly concentrated, extraordinarily complex, harmonious and seductive and have achieved a cult following amongst Burgundy lovers. They are very highly sought after with high prices to match. The wines are world famous for their intensity of flavour and extraordinary complexity and seductiveness. Cros Parantoux and Richebourg are the most sought-after example of the magic and legend of Henri Jayer.

Henri Mayer, Echézeaux 1986

*Grand Cru, Côte de Nuits
Slightly stained and slightly damaged label. Level
0.5cm*

5314 1 magnum *per lot* HK\$45,000-75,000

Henri Mayer, Echézeaux 1990

*Grand Cru, Côte de Nuits
Cut capsule to reveal Domaine and vintage branded
cork. Slightly stained and damaged label. US import
back label. Level 1cm*

5315 1 magnum *per lot* HK\$70,000-120,000

Henri Mayer, Richebourg 1959

*Grand Cru, Côte de Nuits
One Caves Dessilly bottled. One damaged wax capsule
and one slightly damaged plain capsule. One damaged
vintage neck label. Stained and one damaged labels.
One bottle with old version Mayer label. Levels one 4cms
and one 4.5cms*

5316 2 bottles *per lot* HK\$280,000-500,000

5317 NO LOT

Henri Mayer, Richebourg 1962

*Grand Cru, Côte de Nuits
Caves Dessilly bottled. Varied bottle shapes. Slightly
damaged capsules. One sign of old seepage. Two
slightly shrunken corks. Two slightly depressed corks.
Four stained and one badly stained labels. Levels two
4cms, one 4.5cms, one 5cms and one 6cms*

5318 5 bottles *per lot* HK\$140,000-260,000

Henri Mayer, Richebourg 1966

*Grand Cru, Côte de Nuits
Caves Dessilly bottled. Corroded capsules. Slightly
depressed corks. Stained labels. Levels one 3cms and
one 4cms*

5319 2 bottles *per lot* HK\$70,000-120,000

Henri Mayer, Richebourg 1978

*Grand Cru, Côte de Nuits
Two very slightly depressed corks. Two very slightly
damaged labels. US import slip labels. Levels one
1.5cms and two 2.5cms*

5320 3 bottles *per lot* HK\$400,000-650,000

Henri Mayer, Richebourg 1985

*Grand Cru, Côte de Nuits
Cut and damaged capsule to reveal branded cork.
Very slightly stained and very slightly damaged label.
Level 2.5cms*

5321 1 magnum *per lot* HK\$200,000-350,000

Henri Mayer, Richebourg 1985

*Grand Cru, Côte de Nuits
Corroded and damaged capsules. One US import slip
label and two integrated US import labels. One stained
and two very slightly damaged labels. Levels two 3cms
and one 3.5cms*

5322 3 bottles *per lot* HK\$320,000-550,000

Henri Mayer, Richebourg 1985

*Grand Cru, Côte de Nuits
One slightly depressed cork. Two cut capsules to reveal
Mayer branded corks. Slightly stained labels, one slightly
detached. Levels one 1cm, one 1.5cms and one 2.5cms*

5323 3 bottles *per lot* HK\$320,000-550,000

Henri Mayer, Richebourg 1986

*Grand Cru, Côte de Nuits
One cut capsule to reveal fully branded cork. One very
slightly stained and one very slightly damaged labels.
Levels 1cm*

5324 2 magnums *per lot* HK\$240,000-420,000

Henri Mayer, Richebourg 1987

*Grand Cru, Côte de Nuits
One loose capsule to reveal Domaine and vintage
branded cork. Slightly stained labels, two with
handwritten 87 on labels. Levels one 2cms, one 3cms,
one 3.5cms*

5325 3 bottles *per lot* HK\$160,000-260,000

**Henri Jay, Nuits-Saint-Georges Les Meurgers
1976**

Côte de Nuits

Very slightly stained and two slightly damaged integrated US import front labels. Levels one 1.5cms, one 2cms and one 3cms

5326 3 bottles *per lot* HK\$42,000-70,000

**Henri Jay, Nuits-Saint-Georges Les Meurgers
1986**

Côte de Nuits

Very slightly stained and two slightly damaged labels. Levels 1.5cms or better

5327 4 magnums *per lot* HK\$140,000-240,000

**Henri Jay, Nuits-Saint-Georges Les Meurgers
1986**

Côte de Nuits

Very slightly damaged capsules. Slightly stained labels, three slightly damaged. Levels three 1.5cms, four 2cms and one 2.5cms

5328 8 bottles *per lot* HK\$140,000-240,000

**Henri Jay, Vosne-Romanée Cros-Parantoux
1978**

1er Cru, Côte de Nuits

Slightly depressed corks. One cut capsule to reveal Domaine & vintage branded cork with missing vintage neck label. US import slip labels. Slightly stained and three very slightly damaged labels. Levels two 2cms and two 2.5cms

5329 4 bottles *per lot* HK\$200,000-350,000

**Henri Jay, Vosne-Romanée Cros-Parantoux
1986**

1er Cru, Côte de Nuits

One cut capsule to reveal fully branded cork. One very slightly damaged vintage neck label. Slightly stained and two slightly damaged labels. Levels 1.5cms or better

5330 4 magnums *per lot* HK\$320,000-550,000

**Henri Jay, Vosne-Romanée Cros-Parantoux
1988**

1er Cru, Côte de Nuits

Slightly damaged capsules. Slightly wrinkled vintage neck labels, one slightly damaged. Slightly stained and slightly damaged labels. Levels one 1.5cms, one 2.5cms and two 3cms

5331 4 bottles *per lot* HK\$140,000-240,000

**Henri Jay, Vosne-Romanée Cros-Parantoux
1990**

1er Cru, Côte de Nuits

Slightly wrinkled labels. US import slip labels. Levels one 2cms, one 2.5cms and two 4.5cms

5332 4 bottles *per lot* HK\$200,000-400,000



Lot 5320

Henri Jayer, Vosne-Romanée Cros-Parantoux 1990*1er Cru, Côte de Nuits**Very slightly damaged capsules, one cut to reveal fully branded cork. One slightly stained vintage neck label. Two slightly stained and two slightly damaged labels. Levels two 1.5cms, one 3cms, three 4cms*5333 6 bottles *per lot* HK\$350,000-600,000**Henri Jayer, Vosne-Romanée Cros-Parantoux 1993***1er Cru, Côte de Nuits**Very slightly damaged capsules. Slightly stained vintage neck labels. Slightly stained labels, two slightly damaged. Levels four 1.5cms and one 2cms*5334 5 bottles *per lot* HK\$220,000-380,000**Henri Jayer, Vosne-Romanée Cros-Parantoux 1996***1er Cru, Côte de Nuits**Six Congée capsules. One sign of old seepage. One very slightly damaged vintage neck label. Three stained and two very slightly damaged labels. Levels seven 1cm and one 3cms*5335 8 bottles *per lot* HK\$380,000-600,000**Henri Jayer, Vosne-Romanée Cros-Parantoux 1997***1er Cru, Côte de Nuits**Slightly depressed corks. One stained and one slightly stained labels. Levels 1cm*5336 2 bottles *per lot* HK\$70,000-110,000**Henri Jayer, Vosne-Romanée Cros-Parantoux 1998***1er Cru, Côte de Nuits**One sign of old seepage. US import slip labels. Levels 0.5cms*5337 3 bottles *per lot* HK\$90,000-150,000**Henri Jayer, Vosne-Romanée Cros-Parantoux 1998***1er Cru, Côte de Nuits**One sign of old seepage. One damaged vintage neck label. Slightly stained labels, three slightly damaged. Levels 1cm or better*5338 6 bottles *per lot* HK\$190,000-300,000**Henri Jayer, Vosne-Romanée Cros-Parantoux 1999***1er Cru, Côte de Nuits**One cut capsule to reveal fully branded cork. Two slightly damaged labels. US import slip labels*5339 7 bottles *per lot* HK\$450,000-750,000

5340 NO LOT

Henri Jayer, Vosne-Romanée 1988*Côte de Nuits**Six loose capsules. Six slightly wrinkled, one slightly damaged and one damaged integrated US import labels. Levels one 1cm, six 2cms and one 2.5cms*5341 8 bottles *per lot* HK\$95,000-160,000**Henri Jayer, Vosne-Romanée 1995***Côte de Nuits**One Congée capsule. Loose capsules. Slightly wrinkled labels, one very slightly stained. One Japanese and five US import back labels. Levels five 1cm and one 2cms*5342 6 bottles *per lot* HK\$110,000-180,000**Henri Jayer, Vosne-Romanée Les Brûlées 1978***Côte de Nuits**Congée capsule. Slightly depressed cork. Slightly damaged and cut capsule to reveal fully branded cork. Stained label. Level 2.5cms*5343 1 magnum *per lot* HK\$45,000-75,000**Henri Jayer, Vosne-Romanée Les Brûlées 1985***Côte de Nuits**Cut capsule to reveal branded cork. Stained and slightly damaged label. Level 2cms*5344 1 magnum *per lot* HK\$65,000-100,000**Henri Jayer, Vosne-Romanée Les Brûlées 1987***Côte de Nuits**Stained and very slightly damaged label. US import back label. Level 2cms*5345 1 magnum *per lot* HK\$38,000-65,000

Mixed Henri Mayer, Echézeaux 1978 & 1981

1978 Henri Mayer, Echézeaux (2)
One slightly stained label. US import slip labels. Levels 2.5cms

1981 Henri Mayer, Echézeaux (1)
Slightly damaged integrated US import label. Level 2cms

5346 Above 3 bottles per lot HK\$100,000-180,000

Mixed Henri Mayer, Richebourg 1964 & 1969

1964 Henri Mayer, Richebourg (3)
Caves Dessilly bottled. One damaged capsule. Signs of seepage. Slightly damaged capsules. Stained labels. Levels one 2.5cms, one 4cms and one 4.5cms

1969 Henri Mayer, Richebourg (3)
Caves Dessilly bottled. Slightly damaged capsules. One missing vintage neck label, believed 1969. Slightly stained labels. Levels one 2.5cms, one 3cms and one 3.5cms

5347 Above 6 bottles per lot HK\$200,000-350,000

Mixed Formats of Henri Mayer, Richebourg 1978

1978 Henri Mayer, Richebourg magnum (1)
Very slightly depressed cork. Cut capsule to reveal fully branded cork. Slightly stained label. Level 2.5cms

1978 Henri Mayer, Richebourg (1)
Slightly depressed cork. US import slip label. Very slightly damaged label. Level 2cms

5348 Above 1 magnum and 1 bottle per lot HK\$400,000-680,000

Mixed Formats of Henri Mayer, Richebourg 1985

1985 Henri Mayer, Richebourg magnum (1)
Corroded and cut capsule. Damaged vintage neck label. Very slightly stained and very slightly damaged label. Level 4.5cms

1985 Henri Mayer, Richebourg (1)
Cut capsule to reveal branded cork. Slightly stained and very slightly damaged label. Level 2.5cms

5349 Above 1 magnum and 1 bottle per lot HK\$300,000-550,000



Lot 5339

Mixed Henri Mayer, Nuits-Saint-Georges Les Meurgers 1980 & 1985 in Magnum

1980 Henri Mayer, Nuits-Saint-Georges Les Meurgers magnum (1)

Stained and slightly damaged label. US import back label. Level 2.5cms

1985 Henri Mayer, Nuits-Saint-Georges Les Meurgers magnum (1)

Slightly stained and damaged label. US import back label. Level 2cms

5350 Above 2 magnums per lot HK\$65,000-110,000

Mixed Henri Mayer, Vosne-Romanée Cros-Parantoux 1982 Henri Mayer, Vosne-Romanée Cros-Parantoux

Integrated US import label. Japanese import slip label. Level 2.5cms

1991 Henri Mayer, Vosne-Romanée Cros-Parantoux (2)

Very slightly damaged capsules. One very slightly stained vintage neck label. Levels 2cms

1993 Henri Mayer, Vosne-Romanée Cros-Parantoux (1)

Slightly wrinkled label. US import slip label. Level 2cms

1996 Henri Mayer, Vosne-Romanée Cros-Parantoux (1)

Very slightly damaged capsule. Stained vintage neck label. Stained and slightly damaged label. US import slip label. Level 1cm

5351 Above 5 bottles per lot HK\$200,000-320,000

Mixed Henri Mayer et Georges Mayer, Echézeaux

1989 Henri Mayer et Georges Mayer, Echézeaux (1)
Slightly stained vintage neck label and front label. Level 2cms

1991 Henri Mayer et Georges Mayer, Echézeaux (2)
One stained and one slightly damaged labels. Levels 2cms

1999 Henri Mayer et Georges Mayer, Echézeaux (1)
US import slip label. Level 1cm

5352 Above 4 bottles per lot HK\$70,000-120,000

J. F. Mugnier, Musigny 1993

Grand Cru, Côte de Nuits

Slightly loose capsules. One damaged and one slightly damaged labels. US import slip labels. Levels 1.5cms

5353 6 bottles per lot HK\$70,000-120,000

Mixed J. F. Mugnier, Musigny 1990 & 1993 in Magnums

1990 J. F. Mugnier, Musigny magnum (1)
Very slightly stained and slightly damaged label. US import back label. Level 1.5cms

1993 J. F. Mugnier, Musigny magnums (2)
Slightly damaged labels. US import slip labels. Levels one 1cm and one 1.5cms

5354 Above 3 magnums per lot HK\$60,000-90,000



Lot 5354

J. F. Mugnier, Bonnes-Mares 1996

Grand Cru, Côte de Nuits

Levels 1cm

5355 6 bottles per lot HK\$18,000-28,000

Mixed Richebourg**1982 Jean Gros, Richebourg** (1)

Japanese import slip label. Stained vintage neck label and front label. Level 2.5cms

1985 François Gros, Richebourg (1)

Slightly depressed cork. Slightly stained and very slightly damaged label. Level 2.5cms

1993 Anne & François Gros, Richebourg (6)

US import slip labels. Wrinkled labels. Two slightly stained labels. Levels 1cm or better

5356 Above 8 bottles per lot HK\$26,000-42,000

Joseph Drouhin, Musigny 1996

Grand Cru, Côte de Nuits

US import back labels. One stained and two slightly damaged labels. Levels 0.5cm

5357 7 bottles per lot HK\$28,000-48,000

Joseph Roty, Charmes-Chambertin Cuvée de Très Vieilles Vignes 2005

Grand Cru, Côte de Nuits

Very slightly stained labels

5358 4 bottles per lot HK\$11,000-18,000

Mixed Clos de La Roche**1986 Domaine J. Truchot-Martin, Clos de La Roche** (2)

Slightly damaged vintage neck labels. Very slightly stained and slightly damaged labels. Levels one 1.5cms and one 2cms

1989 Domaine J. Truchot-Martin, Clos de La Roche (2)

Slightly damaged vintage neck labels. Slightly stained and very slightly damaged labels. Levels one 2cms and one 2.5cms

1991 Domaine J. Truchot-Martin, Clos de La Roche (4)

One sign of old seepage. Very slightly stained labels. Levels one 2cms and three 2.5cms

1996 Domaine J. Truchot-Martin, Clos de La Roche (1)

Level 0.5cm

5359 Above 9 bottles per lot HK\$40,000-70,000

Mixed Morey-Saint-Denis Clos Sorbés & Gevrey-Chambertin**1986 Domaine J. Truchot-Martin, Morey-Saint-Denis Clos Sorbés** (2)

Stained vintage neck labels and front labels. One front label damaged. Levels 2.5cms

1998 Domaine J. Truchot-Martin, Morey-Saint-Denis Clos Sorbés magnum (1)

Slightly depressed cork. Sign of old seepage. Badly stained and damaged vintage neck label and front label. Level 0.5cm

1988 Domaine J. Truchot-Martin, Gevrey-Chambertin (2)

Stained and slightly damaged labels. Levels one 2cms and one 2.5cms

5360 Above 1 magnum and 4 bottles per lot HK\$11,000-18,000

DOMAINE LEROY

The family can trace its history back to 1868 when François Leroy started the family wine business, Maison Leroy, which was the start of the négociant arm of the business (Maison Leroy wines are bought and therefore not vinified by Leroy). François Leroy's son, Henri acquired half of Domaine de la Romanée-Conti in the early 20th century. Henri's daughter Lalou Bize-Leroy established Domaine Leroy following the purchase of the 12 hectares of Domaine Noëllat in 1988 and Domaine Louis Remy in 1989 and she remains in charge to this day.

Domaine Leroy has adhered to the principles of biodynamic viticulture since 1989. They do not use any weed killers, pesticides, fungicides, insecticides or artificial fertilizers in their 23 hectares of vineyards. Incredibly low yields produce wines that are superbly concentrated and highly sought after.

There is a strict selection of only the finest grapes and resulting very low yields. For example in the challenging vintage of 2008 the yield was only 13 hectolitres per hectare. Grapes are not de-stemmed and whole clusters are fermented in old oak vats with temperature-control. The proportion of new oak varies depending on the wine and vintage.

Domaine Leroy produce nine Grand Cru wines; Corton-Renardes, Richebourg, Romanée-Saint-Vivant, Clos de Vougeot, Musigny, Clos de la Roche, Latricières-Chambertin, Chambertin and Corton-Charlemagne; as well as eight Premier Cru wines such as Vosne-Romanée Les Beaux-Monts and Gevrey-Chambertin Les Combottes, and a further selection of fine red wines such as Pommard and Nuits-Saint-Georges from other Burgundy terroirs. Domaine Leroy is regarded by many as one of the finest producers in Burgundy. Michel Bettane wrote in Vins de France that "Domaine Leroy is a welcome reminder of the difference between the very good and the great". And Robert Parker stated that "Lalou Bize-Leroy stands alone at the top of Burgundy's quality hierarchy. Because she is a perfectionist, and because she has had the courage to produce wines from low yields and bottle them naturally, without fining or filtration". Many would agree with Clive Cotes when he says "This is the greatest estate in Burgundy..."

Domaine Leroy, Vosne-Romanée Les Beaux Monts 2000

1er Cru, Côte de Nuits
Slightly damaged wax capsules. Signs of old seepage.
Very slightly stained and very slightly damaged labels.
Slightly damaged back labels. Levels one 1.5cms, one
2cms and one 2.5cms

5361 3 bottles per lot HK\$13,000-22,000

Mixed Domaine Leroy 2003 & 2005

2003 Domaine Leroy, Nuits-Saint-Georges Les Boudots (3)

Signs of old seepage. Very slightly stained labels.
Slightly damaged back labels. Levels two 2cms and one
3.5cms

2005 Domaine Leroy, Nuits-Saint-Georges Les Boudots (2)

Signs of old seepage. Slightly damaged labels.
Japanese import back labels. Levels 2cms

2005 Domaine Leroy, Nuits-Saint-Georges Les Vignerondes (2)

Signs of old seepage. One damaged wax capsule.
Japanese import back labels. Slightly stained labels and
one very slightly damaged label. Levels 2cms

5362 Above 7 bottles per lot HK\$24,000-40,000

Maison Leroy, Chambertin 1949

Grand Cru, Côte de Nuits
Recent release. One damaged capsule. Slightly
depressed corks. Two signs of old seepage. One slightly
stained and slightly damaged. Levels four 1.5cms and
one 2cms

5363 5 bottles per lot HK\$80,000-130,000

Maison Leroy, Chambertin 1961

Grand Cru, Côte de Nuits
Two slightly depressed corks. One very slightly
damaged label. US import back labels. Levels 1.5cms

5364 3 bottles per lot HK\$45,000-75,000

Maison Leroy, Musigny 1962

Grand Cru, Côte de Nuits
Recent release. Two slightly damaged capsules. Three
signs of old seepage. Three stained labels. Two stained
back labels. Levels four 1.5cms, one 2cms, one 2.5cms
and one 3cms

5365 7 bottles per lot HK\$160,000-260,000

Maison Leroy, Richebourg 1949

Grand Cru, Côte de Nuits
Recent release. One slightly depressed cork. US import
slip labels. Levels 1cm

5366 2 bottles per lot HK\$38,000-65,000

Maison Leroy, La Romanée 1962

Grand Cru, Côte de Nuits
Recent release. US import slip labels. Slightly creased
vintage neck labels. Two very slightly damaged labels.
Slightly damaged back labels. Levels two 2.5cms and
one 3cms

5367 3 bottles per lot HK\$45,000-75,000

Maison Leroy, Bonnes-Mares 1980

Grand Cru, Côte de Nuits
Recent release. Two very slightly damaged labels.
Levels seven 1.5cms or better and one 2.5cms

5368 8 bottles per lot HK\$40,000-70,000

Maison Leroy, Ruchottes-Chambertin 1985

Grand Cru, Côte de Nuits
Recent release. Integrated US import labels. Excellent
appearance. Levels 1.5cms or better

5369 3 bottles per lot HK\$17,000-28,000

Mixed Maison Leroy 1955 & 1969

1955 Maison Leroy, Echézeaux (2)
Slightly depressed corks. Recent release. Slightly
stained labels. Levels one 0.5cm and one 1cm

1969 Maison Leroy, Grands-Echézeaux (3)
Slightly depressed corks. Recent release. Slightly
stained labels. Levels one 1.5cms, one 2cms and one
2.5cms

5370 Above 5 bottles per lot HK\$30,000-50,000

Mixed Clos de Vougeot 1978 & 2001

1978 Maison Leroy, Clos de Vougeot (3)
Recent release. Depressed corks. Slightly stained and
slightly damaged labels. Levels one 2cms and two
2.5cms

2002 Domaine Leroy, Clos de Vougeot (1)
Sign of old seepage. Very slightly stained and very
slightly damaged label. Level 1.5cms

5371 Above 4 bottles per lot HK\$22,000-35,000

Mixed Maison Leroy 1978

1978 Maison Leroy, Mazis-Chambertin (1)

Recent release. Slightly stained label. Level 3cms

1978 Maison Leroy, Beaune (3)

Recent release. Slightly depressed corks. One very slightly damaged label. Levels one 1cm, one 1.5cms and one 2.5cms

1978 Maison Leroy, Beaune Les Cent Vignes (4)

Recent release. Three slightly depressed corks.

Very slightly damaged labels. Levels 4cms

5372 Above 8 bottles per lot HK\$20,000-45,000

Mixed Maison Leroy, Savigny-lès-Beaune 1978

1978 Maison Leroy, Savigny-lès-Beaune Aux Serpentières (4)

Recent release. Two depressed corks. Slightly stained labels. Levels one 3cms, two 3.5cms and one 3cms

1978 Maison Leroy, Savigny-lès-Beaune Les Narbantons (4)

Recent release. Depressed corks. Slightly stained labels. Levels one 1.5cms, one 2cms and two 2.5cms

1978 Maison Leroy, Savigny-lès-Beaune Les Vergelesses (3)

Recent release. Slightly depressed corks. Slightly stained labels. Levels two 2cms and one 3.5cms

5373 Above 11 bottles per lot HK\$18,000-30,000

Mixed Maison Leroy, Pommard & Volnay 1978

1978 Maison Leroy, Pommard Les Vignots (5)

Recent release. Slightly depressed corks. One slightly damaged and one slightly stained vintage neck labels.

Slightly stained labels. Levels three 1cm, one 1.5cms and one 2.5cms

1978 Maison Leroy, Volnay Les Caillerets (3)

Recent release. Depressed corks. Slightly stained and slightly damaged labels. Levels 3.5cms

1978 Maison Leroy, Volnay Santenots (2)

Recent release. Depressed corks. Slightly stained and slightly damaged labels. Levels one 1.2cms and one 2cms

5374 Above 10 bottles per lot HK\$19,000-32,000

Louis Jadot, Bonnes-Mares 1996

Grand Cru, Côte de Nuits

Very slightly damaged and three very slightly stained labels. One very slightly damaged vintage neck label.

Integrated US import labels. Levels 0.5cms or better

5375 7 bottles per lot HK\$9,000-15,000

Méo-Camuzet, Clos de Vougeot 1988

Grand Cru, Côte de Nuits

Slightly stained labels, one slightly detached.

Levels 1.2cms

5376 3 magnums per lot HK\$12,000-20,000

Domaine Ponsot, Clos de la Roche Vieilles Vignes 1990

Grand Cru, Côte de Nuits

Slightly depressed corks. One very slightly damaged capsule. Two very slightly damaged labels. Levels seven 1.5cms or better and one 2.5cms

5377 8 bottles per lot HK\$70,000-120,000

Lots 5377-5378

粉蒸排骨配 Ponsot Clos de La Roche

粉蒸排骨是川菜，排骨醃入味後裹上米粉，鋪于番薯塊上放入蒸籠，蒸熟即成。排骨自是要選取最鮮嫩的小肋排，番薯的作用則是為了隔水，確保肉質鮮嫩可口，但整道菜最關鍵的其實是裹排骨的米粉。米粉以大米為原料，質地柔韌而富有彈性，水煮不糊湯，幹炒不易斷，作為裹排骨的配料，不但可以吸去多餘油份，更可以為排骨增添額外的質感。Ponsot 出產的夜丘的特級田 Clos de La Roche，完全採用老藤釀造，不苛求生物動力、有機栽培等理念，使用一切手段和方法，盡最大的可能釀造反映風土的佳釀。怡人的酸度恰好解掉粉蒸肉的膩感，而黑比諾柔順的單甯不管與排骨還是米粉搭配都非常和諧。

乙未秋日，張翰齡。

Steamed Spare Ribs with Rice Flour and Ponsot Clos de La Roche

Steamed ribs with rice flour is a Sichuan dish. Marinated spare ribs are coated with flavoured rice flour and then steamed on a bed of sweet potatoes. The ribs must be sourced from tender baby back ribs. The sweet potatoes act as a moisture barrier to ensure that the meat is juicy and hearty. The soul of the dish is, nevertheless, the rice flour. Fried, seasoned and made from scratch white rice, the grainy 'flour' has a particular consistency in remaining soft and firm. It does not get starchy when cooked in water nor break down when fried. Providing a coat to the ribs, the rice flour absorbs excessive grease and adds texture to the meat. Ponsot's Clos de La Roche Grand Cru from Côte de Nuits is made purely with old vines. Without venturing any new concepts like biodynamic and organic farming, Ponsot creates exceptional wine using all possible means to honour and reflect the character of the terroir. The subtle acidity helps diluting the greasiness of the meat, and the suave tannins of pinot noir strike a perfect harmony with both the meat and the rice flour.

Autumn 2015. Austin Zhang

Domaine Ponsot, Clos de la Roche Vieilles Vignes 2003

*Grand Cru, Côte de Nuits
One slightly protruding cork. Very slightly damaged labels*

5378 4 magnums *per lot* HK\$28,000-48,000

Emmanuel Rouget, Vosne-Romanée Cros-Parantoux 1999

*1er Cru, Côte de Nuits
Very slightly stained and very slightly damaged labels*

5379 3 bottles *per lot* HK\$26,000-45,000

Mixed Rare Burgundy 1937, 1949 & 1959

1937 Domaine de Lambrays, Clos des Lambrays (1)
Slightly damaged capsule. Badly damaged label. Level 4.5cms

1949 Pierre Ponnelle, Musigny (1)
Sign of seepage. Slightly stained label. Level 5cms

1959 Domaine Michel Gaunoux, Pommard Rugiens (2)

Believed recent release. One cut capsule to reveal unbranded cork. Very slightly stained labels. US import slip labels. Levels one 1cm and one 1.5cms

5380 Above 4 bottles *per lot* HK\$15,000-30,000

Mixed Volnay Clos des Ducs 1999 & Clos de La Roche 2003

1999 Domaine Marquis d'Angerville, Volnay Clos des Ducs (2)

One slightly depressed cork. One slightly stained label

2003 Hubert Lignier, Clos de La Roche Cuvée Romain (4)

5381 Above 6 bottles *per lot* HK\$10,000-16,000

Château Rayas, Châteauneuf-du-Pape Réserve 1978

*Rhône
Slightly damaged capsule. Sign of old seepage. Stained label. Level 3cms*

5382 1 bottle *per lot* HK\$10,000-16,000

Château Rayas, Châteauneuf-du-Pape Réserve 1990

*Rhône
Five signs of seepage. Two wine stained vintage neck labels. One damaged label. Five damaged integrated US import labels. Levels two 2cms, four 2.5cms and one 4cms*

5383 7 bottles *per lot* HK\$60,000-90,000

Domaine du Pegau, Châteauneuf-du-Pape Cuvée da Capo 1998

*Rhône
US import slip labels. Levels 1cm*

5384 4 bottles *per lot* HK\$13,000-20,000

E. Guigal Côte-Rôtie La Landonne 1978

*Rhône
Two slightly corroded and two slightly damaged capsules. Slightly stained and very slightly damaged vintage neck labels. Slightly stained and slightly damaged labels. Slightly stained and slightly damaged US import slip labels. Levels two 0.5cms and one 1.5cms*

5385 3 bottles *per lot* HK\$32,000-55,000

E. Guigal Côte-Rôtie La Landonne 1983

*Rhône
Very slightly protruding corks. Three very slightly damaged capsules. Very slightly damaged vintage neck labels. Very slightly stained and very slightly damaged labels. Levels one 1cm, two 1.5cms and one 2.5cms*

5386 4 bottles *per lot* HK\$14,000-24,000

E. Guigal Côte-Rôtie La Mouline 1985

*Rhône
Five corroded and damaged and one badly damaged capsules. Stained and damaged vintage neck labels and front labels. Three Taiwanese import back labels. Levels one 1cm, three 1.5cms and two 2cms*

5387 6 bottles *per lot* HK\$42,000-70,000

Henri Bonneau, Châteauneuf-du-Pape Réserve de Céléstins 1990

Rhône

One slightly damaged label. US import back labels. Levels three 1cm and one 2cms

5388 4 bottles *per lot* HK\$28,000-48,000

J. L. Chave, Hermitage 1990

Rhône

Four slightly stained and three slightly damaged labels. Five US import back labels. Levels 1.5cms or better

5389 12 bottles *per lot* HK\$55,000-90,000

Mixed J. L. Chave, Ermitage Cuvée Cathelin 1995 & 2000

1995 J. L. Chave, Ermitage Cuvée Cathelin (4)

2000 J. L. Chave, Ermitage Cuvée Cathelin (1)

Very slightly damaged label

5390 Above 5 bottles *per lot* HK\$100,000-180,000

Maison Paul Jaboulet Aîné, Hermitage La Chapelle 1961

Rhône

One slightly corroded capsule. One slightly depressed cork. One stained and damaged and one slightly damaged labels. Levels one 3cms and one 3.5cms

5391 2 bottles *per lot* HK\$130,000-220,000

Maison Paul Jaboulet Aîné, Hermitage La Chapelle 1961

Rhône

One back label states reconditioned at Domaine in 2014. Both believed to be reconditioned. Levels one 2cms and one 2.5cms

5392 2 bottles *per lot* HK\$130,000-220,000

Maison Paul Jaboulet Aîné, Hermitage La Chapelle 1978

Rhône

One slightly depressed cork. One slightly damaged capsule. Two stained and damaged vintage neck labels. One stained and two very slightly stained labels. Levels 3cms

5393 3 magnums *per lot* HK\$40,000-65,000

Lot 5389

烤包子配 Jean-Louis Chave Hermitage Rouge

烤包子是維吾爾族常見的主食，巴黎的飯館和小攤上均有售賣。內地非維吾爾族同胞聚集的地區而不能嘗到這一美食，並非缺乏原料，而是缺少烹飪的器具，烤包子需要用饅坑烤出來才地道。烤包子重在烤而不是蒸發，因此用的是死面。包子皮折成方形，填入羊肉、羊尾巴油丁、洋蔥，以及孜然、胡椒和精鹽等佐料，貼在饅坑壁上烘烤即成。烤好的包子皮色黃亮，而肉質鮮嫩可口，一定需要一款 Syrah 搭配才好，高酸度和單甯支撐起的棱角，與烤包子的肉餡搭配最相宜。JL Chave 的艾米塔基使用 100% 的 Syrah，主要來自陡峭並充滿花崗岩石的 Bessards 地塊，釀造出的酒如同葡萄田一般險峻，令人敬仰。

乙未秋日，張儵翰。

Grilled Buns and Jean-Louis Chave Hermitage Rouge

Grilled buns are commonly seen in the daily meals of Uyghurs in Xinjiang Province and are widely sold in restaurants and food stalls in bazaars. It is not easy to taste this delicacy in non-Uyghurs regions. This is, however, not due to a lack of ingredients but the cooking utensils and stoves specifically adapted to this dish. Only buns made in traditional tandoors are real grilled buns worthy for the name. These buns are grilled, baked but not steamed; therefore the dough is unleavened. The dough, once rolled flat, is folded into a cubic form, shoved with mutton meat, mutton tail fat, and onion, also seasoned with cumin, salt, pepper and other spices. The buns are stuck to the inner walls of the tandoor to grill. Grilled buns are golden in colour and the meat stuffing inside is extremely tender and juicy, which are deserved to be savoured with nothing less than a good syrah, regarding its relatively high acidity and powerful tannins. JL Chave produces 100% syrah Hermitage rouge, with vines located in the granite-strewn Bessards parts of the Hermitage hill. The wines made there are majestic, breath-taking and noble, just like the terroir where they are bred. Autumn 2015. Austin Zhang.

Autumn 2015. Austin Zhang

Maison Paul Jaboulet Aîné, Hermitage La Chapelle 1978

Rhône

One damaged and two slightly damaged capsules. Three depressed and one slightly depressed corks. Slightly stained and slightly damaged neck labels. Three Morgan's Wine LTD Dublin, one Wine Society and eight Malmaison Wines integrated labels. Three stained, nine slightly stained, two slightly damaged and three damaged labels. Levels five 1cm, two 1.5cms, four 2cms and one 2.5cms

5394 12 bottles per lot HK\$80,000-130,000

Maison Paul Jaboulet Aîné, Hermitage La Chapelle 1989

Rhône

Five slightly depressed corks. Very slightly stained labels. Levels two 2cms, four 2.5cms, five 3cms and one 4.5cms

5395 12 bottles per lot HK\$18,000-32,000

Maison Paul Jaboulet Aîné, Hermitage La Chapelle 1990

Rhône

One slightly corroded capsule. Two very slightly damaged neck labels. Three stained and very slightly damaged labels. Levels one 1.5cms, one 2cms and two 2.5cms

5396 4 bottles per lot HK\$14,000-22,000

Maison Paul Jaboulet Aîné, Hermitage La Chapelle 1990

Rhône

Lot 5397: Two very slightly depressed corks. Ten very slightly damaged neck labels. Ten very slightly stained and ten very slightly damaged labels. Eight slightly damaged Malta import back labels. Levels one 1.5cms, eight 2cms, two 2.5cms and one 3cms

Lot 5398: One sign of old seepage. Five very slightly depressed corks. One slightly corroded capsule. Five very slightly damaged neck labels. Very slightly stained and six very slightly damaged labels. Six slightly damaged Malta import back labels. Levels two 1.5cms, four 2cms, five 2.5cms and one 3cms

5397 12 bottles per lot HK\$40,000-70,000

5398 12 "



Lot 5394

Mixed Hermitage La Chapelle 1978 & 1991

1978 Maison Paul Jaboulet Aîné, Hermitage La Chapelle (1)

Very slightly damaged capsule. Stained label. Level 2.5cms

1991 Maison Paul Jaboulet Aîné, Hermitage La Chapelle (10)

One sign of old seepage. One wine stained and one slightly damaged neck labels. Stained labels, one slightly damaged. Levels two 1.5cms, seven 2cms and one 2.5cms

5399 Above 11 bottles per lot HK\$20,000-32,000

Giacomo Conterno, Barolo Monfortino Riserva 1961

Piedmont

Two slightly damaged capsules. Very slightly stained and four slightly damaged labels. Levels base of neck or better

5400 10 bottles per lot HK\$80,000-130,000

Giacomo Conterno, Barolo Monfortino Riserva 1999

Piedmont

Two damaged US import back labels. One very slightly damaged label

5401 6 magnums per lot HK\$55,000-90,000

Mixed Barolo 1967 & 1990

1967 Luigi Calissano, Barolo Riserva Speciale (6)

Four very slightly damaged labels. Levels one 3cms, four 3.5cms and one 4cms

1990 Bartolo Mascarello, Barolo (6)

One very slightly damaged label. Levels 2.5cms

5402 Above 12 bottles per lot HK\$18,000-32,000

Mixed Formats of Amarone della Valpolicella 1996 & 1998

1996 Romano Dal Forno, Amarone della Valpolicella (3)

One sign of old seepage. Damaged and one stained labels. Slightly stained and one damaged back labels. Levels one into neck and two base of neck

1998 Romano Dal Forno, Amarone della Valpolicella magnums (3)

One slightly damaged wax capsule. One sign of old seepage. Slightly damaged back labels. Levels into neck

5403 Above 3 magnums and 3 bottles per lot HK\$26,000-40,000

ANTINORI ESTATE AND SOLAIA

The Antinori family have been involved in the production of wine for over six centuries, ever since, in 1385, Giovanni di Piero Antinori entered as a member, the "Arte Fiorentina", the Winemakers' Guild of the city of Florence. Since then and through twenty six generations, the family has worked tirelessly making innovative decisions, but always maintaining, unaltered, a fundamental respect for tradition and for the territory in which they have operated.

Today the firm is run by Marquis Piero Antinori with the support of his three daughters, Albiera, Allegra, and Alessia, who are directly involved in the Estate. Tradition, passion, and intuition have been the three driving principles which have led the Marquis Antinori firm to become a leader in Italian wine. The Marchesi Antinori firm expresses its passion for viticulture by a constant search for even the smallest areas for quality improvement. The Antinori family has been part, ever since its foundation, of the PFV, the "Premium Familiae Vini", an informal association of winemaking Estates which are still family-owned.

The Tenuta Tignanello Estate is located between the Greve and Pesa river valleys in the heart of the Chianti Classico appellation, between the two hamlets of Montefridolfi and Santa Maria a Macerata, 30 kilometers to the south of the city of Florence. In these 127 hectares of vineyards, the Antinori family, more than anywhere else, have demonstrated their principles and working philosophy: to reconcile tradition and modernity with wines which are strictly and authentically tied to their origin.

Solaia and Tignanello, the two iconic wines of the estate, have been defined by the international press as "among the most influential wines in the viticultural history of Italy" and are a constant symbol for the Antinori family of a continuous challenge, one driven by pure passion.

安東尼世家已經經營葡萄酒逾六個世紀,早在1385年喬萬尼·皮埃羅·安東尼已經加入了佛羅倫斯的釀酒師工會「Arte Fiorentina」。安東尼世家的26代傳人幾百年來堅持釀酒傳統,尊重風土,勇敢創新直至今日。目前酒莊由皮埃羅·安東尼侯爵掛帥,在三個女兒愛蓓拉、阿蕾拉和阿蕾莎的協作下共同經營。傳統、熱情和直覺是安東尼世家屹立于義大利釀酒世家之巔的核心精神。安東尼世家的熱情體現在對最小細節上表現出來的執著與精益求精。安東尼世家是「第一葡萄酒家族」的創始成員之一,是全球公認頂尖的葡萄酒家族。天娜莊園位於佛羅倫斯市區以南30公里的經典動地產區的中心地帶,格萊夫和沛沙河谷之間的蒙福多村和馬切拉—聖瑪利亞村的交界位置。在這127公頃的葡萄園裡,安東尼世家踐行著他們的釀酒理念:糅合傳統與現代精粹,釀造忠實于風土的佳釀。索拉雅和天娜,酒莊所產佳釀裡的雙璧,被譽為「義大利釀酒史上的頂尖佳釀」,也是安東尼世家勇於面對挑戰、傾注滿腔熱情釀酒的象徵。

Antinori, Guado Al Tasso 2001

Tuscany

*Three very slightly stained and one very slightly damaged labels*5404 17 bottles *per lot* HK\$9,000-15,000**Antinori, Solaia 2002**

Tuscany

*One very slightly stained label*5405 2 double-magnums *per lot* HK\$7,000-12,000**Antinori, Solaia 2002**

Tuscany

*Two slightly damaged labels*5406 9 magnums *per lot* HK\$16,000-26,000**Mixed Formats of Solaia 1997****1997 Antinori, Solaia** magnum (1)
*Slightly stained and slightly damaged label. Level base of neck***1997 Antinori, Solaia** (2)
One very slightly damaged label. Levels into neck
5407 Above 1 magnum and 2 bottles
per lot HK\$7,500-13,000**Mixed Antinori, Solaia 2000 & 2001****2000 Antinori, Solaia** (3)
*Two slightly damaged labels***2001 Antinori, Solaia** (8)
Very slightly damaged labels
5408 Above 11 bottles *per lot* HK\$14,000-22,000**Tenuta dell'Ornellaia, Masseto 1987**

Tuscany

*Very slightly stained labels. One slightly damaged back label. Levels base of neck*5409 4 bottles *per lot* HK\$14,000-24,000**Tenuta dell'Ornellaia, Masseto 2000**

Tuscany

5410 4 bottles *per lot* HK\$14,000-24,000**Tenuta dell'Ornellaia, Masseto 2001**

Tuscany

5411 4 bottles *per lot* HK\$20,000-35,000**Mixed Masseto 1992 & 2002****1992 Tenuta dell'Ornellaia, Masseto** (2)*One slightly damaged label. Levels into neck***2002 Tenuta dell'Ornellaia, Masseto** (3)5412 Above 5 bottles *per lot* HK\$18,000-30,000**Mixed Masseto 1993 & 1997****1993 Tenuta dell'Ornellaia, Masseto** (3)*Very slightly stained labels, one slightly damaged.**Levels base of neck***1997 Tenuta dell'Ornellaia, Masseto** (3)*One slightly depressed cork. Levels base of neck*5413 Above 6 bottles *per lot* HK\$24,000-40,000**Tenuta dell'Ornellaia, Ornellaia 1990**

Tuscany

*Damaged wax capsule. Stained label. Level into neck*5414 1 double-magnum *per lot* HK\$6,000-10,000**Tenuta dell'Ornellaia, Ornellaia 2001**

Tuscany

*Two signs of old seepage. Two slightly stained labels, one very slightly damaged. One stained back label and two stained Chinese import back labels*5415 3 double-magnums *per lot* HK\$16,000-26,000

Tenuta dell'Ornellaia, Ornellaia 2002

Tuscany

Two very slightly damaged labels. One Taiwanese import back label

5416 5 magnums per lot HK\$9,000-15,000

Mixed Ornellaia 1997 & 2002

1997 Tenuta dell'Ornellaia, Ornellaia (2)

Very slightly stained labels. Levels into neck

2002 Tenuta dell'Ornellaia, Ornellaia (4)

Three very slightly damaged labels. Levels into neck

5417 Above 6 bottles per lot HK\$7,000-12,000

Tenuta San Guido, Sassicaia 2009

Tuscany

Nine very slightly stained labels

5418 18 bottles per lot HK\$20,000-35,000

Mixed Formats of Sassicaia 1997 & 1998

1997 Tenuta San Guido, Sassicaia half-bottles (6)

Three slightly stained labels. Levels base of neck

1998 Tenuta San Guido, Sassicaia (5)

Three slightly damaged labels. Levels base of neck

5419 Above 5 bottles and 6 half-bottles per lot HK\$12,000-22,000

Mixed Sassicaia in Magnums

1986 Tenuta San Guido, Sassicaia magnum (1)

Slightly damaged label. Level into neck

1995 Tenuta San Guido, Sassicaia magnum (1)

Level into neck

1998 Tenuta San Guido, Sassicaia magnum (1)

2000 Tenuta San Guido, Sassicaia magnums (2)

All slightly depressed corks

5420 Above 5 magnums per lot HK\$12,000-20,000

Mixed Sassicaia 2001 & 2002

2001 Tenuta San Guido, Sassicaia (3)

2002 Tenuta San Guido, Sassicaia (2)

5421 Above 5 bottles per lot HK\$6,000-10,000

Mixed Aalto PS 2001 & 2005

2001 Aalto PS (6)

Very slightly damaged labels

2005 Aalto PS (6)

5422 Above 12 bottles per lot HK\$10,000-15,000

Mixed Formats of Aalto PS & Nebro 2001

2001 Aalto PS magnums (4)

Slightly stained labels

2001 Finca Villacreces, Nebro (4)

5423 Above 4 magnums and 4 bottles per lot HK\$11,000-18,000



Lot 5411

Mixed Dominio De Pingus 1999 & 2004

1999 Dominio De Pingus (1)
Slightly stained label

2004 Dominio De Pingus (3)
One slightly damaged label. US import slip labels

5424 Above 4 bottles per lot HK\$22,000-35,000

Vega Sicilia, Unico 1990

Ribera del Duero
One sign of old seepage. Four slightly stained labels.
Levels base of neck

5425 6 bottles per lot HK\$14,000-22,000

Vega Sicilia, Unico 1995

Ribera del Duero
Three very slightly damaged labels. Levels into neck

5426 12 bottles per lot HK\$28,000-45,000



Lot 5424

Vega Sicilia, Unico 1996

Ribera del Duero
Nine very slightly stained labels. Levels into neck
5427 12 bottles per lot HK\$26,000-45,000

Mixed Vega Sicilia Unico 1973, 1974 & 1981 in Magnum

1973 Vega Sicilia, Unico magnum (1)
Very slightly damaged label. Level base of neck

1974 Vega Sicilia, Unico magnum (1)
Sign of old seepage. Slightly stained and slightly damaged label. Level top-shoulder

1981 Vega Sicilia, Unico magnum (1)
Very slightly stained and very slightly damaged label.
Level base of neck

5428 Above 3 magnums per lot HK\$15,000-26,000

Mixed Vega Sicilia Unico 1974, 1976, 1994 & 1995

1974 Vega Sicilia, Unico (1)
Slightly protruding cork. Sign of old seepage. Stained and slightly damaged label. Level into neck

1976 Vega Sicilia, Unico (1)
Slightly stained and slightly damaged label. Level top-shoulder

1994 Vega Sicilia, Unico (1)
Very slightly stained label. Level into neck

1995 Vega Sicilia, Unico (1)
Very slightly damaged label. Level into neck

5429 Above 4 bottles per lot HK\$10,000-17,000

Mixed Vega Sicilia, Unico 1995 & 1996

1995 Vega Sicilia, Unico (8)
Levels into neck

1996 Vega Sicilia, Unico (4)
One very slightly damaged label. Levels into neck

5430 Above 12 bottles per lot HK\$28,000-45,000

Egon Muller, Scharzhofberger Riesling Trockenbeereauslese 2005

Germany
Very slightly damaged label. Level 1.5cms
5431 1 magnum per lot HK\$90,000-150,000

Dalla Valle Vineyards, Cabernet Sauvignon 1994

Napa Valley
Very slightly stained labels, three very slightly damaged.
UK import slip labels. Levels base of neck or better

5432 12 bottles per lot HK\$8,500-14,000

Dalla Valle Vineyards, Cabernet Sauvignon 2001

Napa Valley

Four very slightly damaged labels. UK import slip labels

5433 12 bottles *per lot* HK\$7,500-12,000

Dalla Valle Vineyards, Cabernet Sauvignon 2002

Napa Valley

Four very slightly damaged labels. UK import slip labels

5434 12 bottles *per lot* HK\$7,500-12,000

Mixed Harlan Estate 1997 & 1998

1997 Harlan Estate

(3)

One very slightly stained back label

1998 Harlan Estate

(3)

One very slightly depressed cork. Two very slightly damaged back labels

5435 Above 6 bottles *per lot* HK\$30,000-45,000

Mixed Formats of Harlan Estate 2000

2000 Harlan Estate

magnums (3)

Slightly damaged back labels

2000 Harlan Estate

(2)

5436 Above 3 magnums and 2 bottles
per lot HK\$26,000-45,000

Mixed Harlan Estate 2001 & 2002

2001 Harlan Estate

(2)

One slightly stained label. One UK import back label

2002 Harlan Estate

(4)

5437 Above 6 bottles *per lot* HK\$32,000-55,000

Dominus 1997

Napa Valley

One slightly stained label

5438 6 magnums *per lot* HK\$12,000-20,000

Dominus 2001

Napa Valley

Three very slightly damaged labels

5439 9 magnums *per lot* HK\$20,000-35,000

Lots 5435-5437

Pork Offal Stew and Harlan Estate

Pork Offal Stew is a classic street food of old Beijing. While its true origin is disputed, it is without a doubt a dish of ordinary people. Pork Offal Stew today is made using fresh pork offal (heart, liver, intestines, lung, etc.), blanched and then slow stewed with star anise, crushed garlic, mandarin peel, spices and seasoning. It is served with chopped Chinese baked buns, and can be eaten with a wide range of condiments like chilli oil, crushed garlic, chopped chives or fermented bean curd. As the stew has a strong taste, it must be paired with full-bodied wines like the Californian Harlan Estate Cabernet Sauvignon & Blends. The exact grape varieties of Harlan's crus change every year but regularly include a high percentage of Cabernet Sauvignon. The unique Californian terroir gives birth to the wine's rich body, ripe tannins and powerful concentration. Together with the blackcurrant notes typical of a Cabernet Sauvignon, the wine is nothing less than impressive.

Autumn 2015. Austin Zhang



Lot 5437

Mixed Formats of Dominus 1983 & 1994

1983 Dominus (6)
Corroded capsules, one slightly damaged. Very slightly stained labels. Levels into neck

1994 Dominus magnums (2)
Levels into neck

5440 Above 2 magnums and 6 bottles
per lot HK\$11,000-18,000

Mixed Dominus 1991 & 2003 in Double-Magnum

1991 Dominus double-magnum (1)
Very slightly depressed cork. Slightly stained label. Level into neck

2003 Dominus double-magnum (1)
Very slightly stained label

5441 Above 2 double-magnums *per lot HK\$10,000-17,000*

Joseph Phelps, Insignia 1997

*Napa Valley
 Levels base of neck or better*

5442 22 bottles *per lot HK\$28,000-48,000*

Vertical of Opus One

1986 Opus One (2)
Badly corroded capsules. One sign of old seepage. Stained labels. Levels one base of neck and one top-shoulder

1995 Opus One (3)
Very slightly stained labels. Levels into neck

1996 Opus One (6)
Levels into neck

1998 Opus One (5)
One very slightly damaged label. Levels into neck

2003 Opus One (2)

5443 Above 18 bottles *per lot HK\$28,000-48,000*

Ridge Vineyards, Monte Bello 1999

Santa Cruz

5444 9 bottles *per lot HK\$6,500-11,000*

Mixed Screaming Eagle, Cabernet Sauvignon 1993 & 2003

1993 Screaming Eagle, Cabernet Sauvignon (2)
One slightly depressed cork. Very slightly damaged labels. Levels into neck

2003 Screaming Eagle, Cabernet Sauvignon (1)
Signs of old seepage. Chinese import back label

5445 Above 3 bottles *per lot HK\$45,000-80,000*

Shafer Vineyards Hillside Select, Cabernet Sauvignon 2001

Napa Valley

5446 6 bottles *per lot HK\$16,000-26,000*

Mixed Penfolds Grange 1969 & 1971

1969 Penfolds Grange (3)
Two recorked at the Penfolds recorking clinic in 1994 and one in 1996. Stained labels, two very slightly damaged. Levels base of neck or better

1971 Penfolds Grange (4)
Two very slightly damaged capsules. Two slightly stained and one stained label. Levels one base of neck and three top-shoulder

5447 Above 7 bottles *per lot HK\$42,000-70,000*

Mixed Penfolds Grange 1986, 1990, 1992 & 1996

1986 Penfolds Grange (2)
One stained and slightly damaged label. Levels base of neck

1990 Penfolds Grange (5)
One slightly depressed cork. Two slightly damaged labels. Levels base of neck

1992 Penfolds Grange (2)
One slightly damaged capsule. Very slightly damaged labels with hand writing. Levels base of neck

1996 Penfolds Grange (1)
Very slightly damaged label. Level into neck

5448 Above 10 bottles *per lot HK\$30,000-50,000*

Mixed Penfolds Grange 1993 & 1994

1993 Penfolds Grange (6)
Levels base of neck

1994 Penfolds Grange (6)
Two slightly depressed corks. Levels into neck

5449 Above 12 bottles *per lot HK\$28,000-45,000*

Mixed Penfolds Grange 1996 & 1998

1996 Penfolds Grange (6)
Three very slightly damaged labels. Levels into neck

1998 Penfolds Grange (6)

5450 Above 12 bottles *per lot HK\$32,000-55,000*



DEDICATED TO
MAX SCHUBERT
1873-1961

Penfolds

Grange

SOUTH AUSTRALIA
SHIRAZ

VINTAGE 1998 BOTTLED 1997

Grange is recognized as Australia's and indeed one of the world's finest red wines. This great wine, developed by Max Schubert commencing with the 1951 vintage, is made from low yielding Shiraz vines grown in coastal vineyards in South Australia and matured in new American oak hogsheads prior to bottling.

DEDICATED TO
MAX SCHUBERT
1873-1961

Penfolds

Grange

SOUTH AUSTRALIA
SHIRAZ

VINTAGE 1988 BOTTLED 1989

Grange is recognized as Australia's and indeed one of the world's finest red wines. This great wine, developed by Max Schubert commencing with the 1951 vintage, is made from low yielding Shiraz vines grown in coastal vineyards in South Australia and matured in new American oak hogsheads prior to bottling.

WINE OF AUSTRALIA
14.5% VOL

Penfolds

Grange

SOUTH AUSTRALIA
SHIRAZ

VINTAGE 1988 BOTTLED 1989

Grange is recognized as Australia's and indeed one of the world's finest red wines. This great wine, developed by Max Schubert commencing with the 1951 vintage, is made from low yielding Shiraz vines grown in coastal vineyards in South Australia and matured in new American oak hogsheads prior to bottling.

Lot 5450

Mixed Formats of Penfolds Grange 2001 & 2006**2001 Penfolds Grange** (4)*Slightly depressed corks***2006 Penfolds Grange** magnum (1)*In original wooden case*5451 Above 1 magnum and 4 bottles
per lot HK\$15,000-26,000**Penfolds Bin 90A 1990***South Australia**Four slightly depressed corks. Four very slightly damaged labels. Levels into neck*

5452 10 bottles per lot HK\$24,000-40,000

Penfolds Bin 707 1996*South Australia**UK import back labels. Levels into neck*

5453 11 bottles per lot HK\$14,000-22,000

Torbreck, Descendant 2001*Barossa Valley**One very slightly damaged label. Eight Austrian and eight Irish import slip labels*

5454 16 bottles per lot HK\$10,000-17,000

Torbreck, Run Rig 2002*Barossa Valley*

5455 21 bottles per lot HK\$26,000-45,000

Torbreck, Les Amis 2003*Barossa Valley**Three slightly depressed corks. One slightly damaged label. Three damaged back labels*

5456 25 bottles per lot HK\$32,000-55,000

Torbreck, The Factor 2003*Barossa Valley**Swiss import slip labels*

5457 21 bottles per lot HK\$13,000-22,000

Mixed Single Vineyard Shiraz & Reserve Pinot Noir**2003 The Standish, Single Vineyard Shiraz** (19)*Three very slightly damaged labels***2009 Bass Phillip, Reserve Pinot Noir** (2)

5458 Above 21 bottles per lot HK\$16,000-28,000

Mixed Taylor's 1945 & Krohn's 1957 Vintage Port**1945 Taylor's Vintage Port** (1)*Slightly damaged wax capsule. Sign of seepage.**Detached, wrinkled and slightly damaged handwritten label. Level base of neck***1957 Krohn's Vintage Port** (1)*Slightly damaged wax capsule. Damaged label. Level base of neck*

5459 Above 2 bottles per lot HK\$7,000-12,000

Quinta do Noval Vintage Port 1963*Portugal**Slightly damaged labels. Levels two into neck and three base of neck*

5460 5 bottles per lot HK\$6,500-11,000

Dow's Vintage Port 1977*Portugal**In original gift box*

5461 1 tappit hen (2.1L) per lot HK\$6,000-10,000

Quinta do Noval Nacional 1994*Portugal**Levels into neck*

5462 2 bottles per lot HK\$19,000-32,000

Taylor Fladgate & Yeatman, Scion NV*Portugal**In original wooden case*

5463 1 bottle per lot HK\$16,000-26,000

End of Sale
拍賣結束



Index by Vintage

WINE	Lot No.	WINE	Lot No.
CHAMPAGNE			
1949		Dom Pérignon	5039-5040
Krug, Collection Vintage	5004	Philipponnat, Clos des Goisses	5047-5048
1959		Salon, Le Mesnil	5051
Dom Pérignon Oenothèque	5027	1999	
1961		Bollinger, La Grande Année Brut	
Billecart-Salmon, Brut Vintage	5001	James Bond 007 Edition	5002
1966		2000	
Louis Roederer, Cristal	5024	Deutz, Amour de Deutz	5003
Dom Pérignon	5037		
1969		MIXED	
Dom Pérignon Oenothèque	5028	Mixed Krug Clos du Mesnil 1996 & 1998	5020
Dom Pérignon	5038	Mixed Krug Brut Vintage 1988 & 1990	5021
1973		Mixed Formats of Krug 1982 & 1985	5022
Dom Pérignon Oenothèque	5029	Mixed Krug 1995 & 1996	5023
1975		Vertical of Louis Roederer Cristal	5026
Dom Pérignon Oenothèque	5030-5031	Mixed Dom Pérignon 1955 & 1962	5041
1976		Mixed Dom Pérignon Oenothèque 1962 & 1971	5042
Dom Pérignon Oenothèque	5032	Mixed Formats of Dom Pérignon 1964	5043
1979,		Mixed Formats of Dom Pérignon 1971	5044
Krug, Collection Vintage	5005	Mixed Dom Pérignon & Dom Pérignon Rosé 1996	5045
Krug, Clos du Mesnil	5012		
Krug, Brut Vintage	5017	BORDEAUX WHITE	
Louis Roederer, Cristal	5025	1921	
Piper Heidsieck, Brut Cuvée Rare Millesime	5049	Château d'Yquem	5184
1981		1949	
Krug, Collection Vintage	5006	Château d'Yquem	5185
Krug, Brut Vintage	5018	1967	
1983		Château d'Yquem	5186
Dom Pérignon Oenothèque	5033	1975	
1985		Château d'Yquem	5187
Krug, Collection Vintage	5007	1983	
1988		Château d'Yquem	5188
Krug, Clos du Mesnil	5013-5014	1990	
Krug, Brut Vintage	5019	Château d'Yquem	5189
1989			
Philipponnat, Clos des Goisses	5046	MIXED	
1990		Mixed Château d'Yquem 1934, 1959 & 1975	5190
Dom Pérignon Oenothèque Rosé	5036		
Salon, Le Mesnil	5050	BORDEAUX RED	
1992		1945	
Dom Pérignon Oenothèque	5034	Château Mouton Rothschild	5075
1993		Château Palmer	5105
Dom Pérignon Oenothèque	5035	Château La Mission-Haut-Brion	5129
1995		Château Trotanoy	5168
Krug, Clos d'Ambonnay	5008	Château Ausone	5171
Krug, Clos d'Ambonnay	5009	1947	
Krug, Clos du Mesnil	5015	Château Haut-Brion	5115
1996		Vieux Château Certan	5169
Krug, Clos d'Ambonnay	5010-5011	Château Cheval Blanc	5174-5177
Krug, Clos du Mesnil	5016	1948	
		Vieux Château Certan	5170

Index by Vintage

WINE	Lot No.	WINE	Lot No.
1949		Petrus	5143
Château Lafite-Rothschild	5052	Château Lafleur	5162-5163
Château La Mission-Haut-Brion	5130	1995	
Château Cheval Blanc	5178-5179	Château Latour	5068
1950		Château Mouton Rothschild	5080
Clos L'Eglise Clinet	5158	Château Margaux	5096
1953		Château Margaux	5097
Château Lafite-Rothschild	5053	Château Haut-Brion	5120-5122
Château Mouton Rothschild	5076	Le Pin	5152
Château Margaux	5091	1996	
1955		Château Latour	5069
Château Cheval Blanc	5180	Château Margaux	5098-5099
1959		1998	
Château Lafite-Rothschild	5054	Château Lafite-Rothschild	5058
Château Mouton Rothschild	5077	Château Mouton Rothschild	5081
Château Haut-Brion	5116	Petrus	5144
1961		Le Pin	5153
Château Latour	5064	2000	
Château Palmer	5106-5107	Château Lafite-Rothschild	5059
Château La Mission-Haut-Brion	5131	Château Latour	5070
Château L'Evangile	5167	Château Mouton Rothschild	5082
1964		Château Margaux	5100-5101
Petrus	5139	Château Haut-Brion	5123
1975		Petrus	5145
Château La Mission-Haut-Brion	5132-5134	2001	
Petrus	5140	Petrus	5146
Château Lafleur	5160	Château Cheval Blanc	5182
1982		2002	
Château Lafite-Rothschild	5055	Le Pin	5154
Château Latour	5065-5066	2003	
Château Mouton Rothschild	5078	Château Lafite-Rothschild	5060
Château Margaux	5092	Château Haut-Brion	5124
Château La Mission-Haut-Brion	5135	2004	
Petrus	5141	Petrus	5147
Château Lafleur	5161	2005	
Château Latour a Pomerol	5166	Château Haut-Brion	5125
Château Cheval Blanc	5181	2006	
1983		Petrus	5148
Château Palmer	5108-5109	2009	
1986		Château Mouton Rothschild	5083
Château Lafite-Rothschild	5056-5057	Château Haut-Brion	5126
Château Latour	5067	Château La Mission-Haut-Brion	5137
Château Mouton Rothschild	5079	Le Pin	5155
Château Margaux	5093	2010	
1989		Château Palmer	5113-5114
Château Palmer	5110-5112	2013	
Château Haut-Brion	5117-5119	Petrus	5149
Château La Mission-Haut-Brion	5136		
Petrus	5142		
1990			
Château Margaux	5094-5095		
		MIXED	
		Mixed Château Lafite-Rothschild 1995 & 1997 in Magnums	5061

Index by Vintage

WINE	Lot No.	WINE	Lot No.
Mixed Château Lafite-Rothschild 1995 & 1996	5062	2002	
Mixed Château Lafite-Rothschild 1989, 1999 & 2003	5063	J. F. Coche-Dury, Corton-Charlemagne	5197
Mixed Formats of Château Latour 1952	5071	Domaine de la Romanée-Conti, Montrachet	5211
Mixed Formats of Château Latour 1959	5072	Domaine Leflaive, Chevalier-Montrachet	5220
Mixed Château Latour 1986 & 1995	5073	2004	
Mixed Château Latour 1990, 1995 & 2003	5074	Domaine des Comtes Lafon, Montrachet	5206
Mixed Château Mouton Rothschild 1952, 1955 & 1959	5084	Domaine de la Romanée-Conti, Montrachet	5212
Mixed 1960's & 1970's Château Mouton Rothschild	5085	2005	
Mixed 1980's Château Mouton Rothschild	5086	Domaine Leflaive, Chevalier-Montrachet	5221
Mixed Formats of Château Mouton Rothschild 1986	5087	2006	
Mixed 1990's Château Mouton Rothschild	5088	Domaine de la Romanée-Conti, Montrachet	5213
Mixed Formats of Château Mouton Rothschild 1996	5089	Domaine Leflaive, Bâtard-Montrachet	5217
Vertical of Château Mouton Rothschild 1945-2005	5090	Domaine Leflaive, Bâtard-Montrachet	5218
Mixed Château Margaux 1978 & 1983	5102	2008	
Mixed Formats of Château Margaux 1985	5103	Domaine Leflaive, Chevalier-Montrachet	5222
Mixed Château Margaux 2001 & 2003 in Half-Bottles	5104	2009	
Mixed Formats of Château Haut-Brion 1961 & 1989	5127	Domaine Jacques Prieur, Montrachet	5230
Mixed Château Haut-Brion 1975 & 1985	5128	Domaine Jacques Prieur, Montrachet	5231
Mixed Château La Mission-Haut-Brion 1953 & 1959	5138	2010	
Mixed Formats of Petrus 1987, 1992, 1997 & 2001	5150	Domaine des Comtes Lafon, Montrachet	5207
Mixed Petrus 1996, 1999 & 2013 in Magnum	5151		
Mixed Le Pin 1985 & 1989	5156	MIXED	
Mixed Le Pin 1994, 1996, 1997 & 1998	5157	Mixed Bouchard Père & Fils, Montrachet 1996 & 1999	5191
Mixed Formats of Château Clinet 1989	5159	Mixed J. F. Coche-Dury, Meursault Les Casse-Tête &	
Mixed Château Lafleur 1966 & 1979	5164	Meursault-Perrières 1978	5199
Mixed Château Lafleur 1993, 1994 & 2001	5165	Mixed J. F. Coche-Dury, Corton-Charlemagne	
Mixed Château Cheval Blanc 1950, 1953 & 1955	5183	1988 & 1997	5200
		Mixed Formats of J. F. Coche-Dury,	
BURGUNDY WHITE		Meursault-Perrières 1989	5201
1986		Mixed J. F. Coche-Dury, Corton-Charlemagne &	
J. F. Coche-Dury, Corton-Charlemagne	5192	Meursault-Perrières 2000	5202
1989		Mixed Domaine Comte Georges de Vogüe,	
J. F. Coche-Dury, Corton-Charlemagne	5193	Musigny Blanc 1979 & 1991	5204
Domaine des Comtes Lafon, Montrachet	5205	Mixed DRC Montrachet 2003 & 2004	5214
1990,		Mixed Domaine Leflaive, Chevalier-Montrachet 1988	
J. F. Coche-Dury, Corton-Charlemagne	5194	& 1996	5223
Domaine de la Romanée-Conti, Montrachet	5209	Mixed Domaine Leflaive, Chevalier-Montrachet 2000	
1992		& 2003	5224
J. F. Coche-Dury, Corton-Charlemagne	5195	Mixed Formats of Domaine Leflaive,	
J. F. Coche-Dury, Meursault-Perrières	5198	Bâtard-Montrachet & Chevalier-Montrachet 2011	5226
Domaine Comte Georges de Vogüe, Musigny Blanc	5203	Mixed Louis Latour, Montrachet & Bâtard-Montrachet	5227
Domaine Ramonet, Bâtard-Montrachet	5232	Mixed Bâtard-Montrachet	5228
1996		Mixed Domaine Michel Niellon,	
J. F. Coche-Dury, Corton-Charlemagne	5196	Chevalier-Montrachet 2002 & 2005	5229
Domaine de la Romanée-Conti, Montrachet	5210	Mixed Domaine Ramonet, Montrachet 1995 & 2006	5233
Domaine Leflaive, Bâtard-Montrachet	5215		
Domaine Leflaive, Bâtard-Montrachet	5216	BURGUNDY RED	
Domaine Leflaive, Chevalier-Montrachet	5219	1945	
1997		Domaine Comte Georges de Vogüe, Musigny	5251
Domaine d'Auvenay, Chevalier-Montrachet	5208	1947	
1999		Domaine Comte Georges de Vogüe,	
Domaine Leflaive, Montrachet	5225	Musigny Vieilles Vignes	5244

Index by Vintage

WINE	Lot No.	WINE	Lot No.
Domaine Comte Georges de Vogüe, Musigny 1949	5252	Henri Mayer, Vosne-Romanée Méo-Camuzet, Clos de Vougeot 1989	5341 5376
Domaine Comte Georges de Vogüe, Musigny Maison Leroy, Chambertin Maison Leroy, Richebourg 1959	5253 5363 5366	Domaine de la Romanée-Conti, Romanée-Saint-Vivant 1990	5298
Henri Mayer, Richebourg 1961	5316	Armand Rousseau, Chambertin	5234
Maison Leroy, Chambertin 1962	5364	Armand Rousseau, Chambertin-Clos-de-Bèze	5236
Henri Mayer, Richebourg	5318	Domaine de la Romanée-Conti, Romanée-Conti	5258
Maison Leroy, Musigny	5365	Domaine de la Romanée-Conti, La Tâche	5276
Maison Leroy, La Romanée 1966	5367	Domaine Dujac, Clos de La Roche	5304
Henri Mayer, Richebourg 1969	5319	Domaine Dujac, Clos Saint-Denis	305
Domaine de la Romanée-Conti, Richebourg 1971	5287	Domaine Faiveley, Chambertin-Clos-de-Bèze	5306
Domaine Comte Georges de Vogüe, Chambolle-Musigny Les Amoureuses	5249	Domaine Georges Roumier, Musigny	5310
Domaine de la Romanée-Conti, Richebourg 1976	5288	Henri Mayer, Echézeaux	5315
Henri Mayer, Nuits-Saint-Georges Les Meurgers 1978	5326	Henri Mayer, Vosne-Romanée Cros-Parantoux	5332-5333
Domaine de la Romanée-Conti, La Tâche	5274	Domaine Ponsot, Clos de La Roche Vieilles Vignes 1993	5377
Henri Mayer, Richebourg	5320	Domaine de la Romanée-Conti, La Tâche	5277
Henri Mayer, Vosne-Romanée Cros-Parantoux	5329	Henri Mayer, Vosne-Romanée Cros-Parantoux	5334
Henri Mayer, Vosne-Romanée Les Brûlées 1980	5343	J. F. Mugnier, Musigny 1995	5353
Domaine de la Romanée-Conti, Romanée-Conti Maison Leroy, Bonnes-Mares 1985	5256 5368	Henri Mayer, Vosne-Romanée 1996	5342
Domaine de la Romanée-Conti, Romanée-Conti	5257	Armand Rousseau, Chambertin-Clos-de-Bèze	5237
Domaine de la Romanée-Conti, La Tâche	5275	Domaine de la Romanée-Conti, Romanée-Conti	5259
Domaine Georges Roumier, Bonnes-Mares	5308	Henri Mayer, Vosne-Romanée Cros-Parantoux	5335
Domaine Georges Roumier, Musigny	5309	J. F. Mugnier, Bonnes-Mares	5355
Domaine Georges Roumier, Chambolle-Musigny Les Amoureuses	5311	Joseph Drouhin, Musigny	5357
Henri Mayer, Richebourg	5321-5323	Louis Jadot, Bonnes-Mares 1997	5375
Henri Mayer, Vosne-Romanée Les Brûlées	5344	Domaine de la Romanée-Conti, Romanée-Conti 1998	5260
Maison Leroy, Ruchottes-Chambertin 1986	5369	Henri Mayer, Vosne-Romanée Cros-Parantoux	5336
Henri Mayer, Echézeaux	5314	Domaine de la Romanée-Conti, Romanée-Conti	5261
Henri Mayer, Richebourg	5324	Henri Mayer, Vosne-Romanée Cros-Parantoux	5337-5338
Henri Mayer, Nuits-Saint-Georges Les Meurgers	5327-5328	1999	
Henri Mayer, Vosne-Romanée Cros-Parantoux 1987	5330	Domaine de la Romanée-Conti, Romanée-Conti	5262
Domaine de la Romanée-Conti, Richebourg	5289	Domaine de la Romanée-Conti, La Tâche	5278
Henri Mayer, Richebourg	5325	Henri Mayer, Vosne-Romanée Cros-Parantoux	5339
Henri Mayer, Vosne-Romanée Les Brûlées 1988	5345	Emmanuel Rouget, Vosne-Romanée Cros-Parantoux 2000	5379
Henri Mayer, Vosne-Romanée Cros-Parantoux	5331	Domaine Leroy, Vosne-Romanée Les Beaux Monts 2001	5361
		Domaine de la Romanée-Conti, Romanée-Conti 2002	5263
		Bouchard Père & Fils, La Romanée 2003	5242
		Domaine Ponsot, Clos de La Roche Vieilles Vignes 2004	5378
		Armand Rousseau, Chambertin	5235
		Christophe Roumier, Ruchottes-Chambertin	5243
		Domaine de la Romanée-Conti, La Tâche	5279

Index by Vintage

WINE	Lot No.	WINE	Lot No.
Domaine de la Romanée-Conti, Richebourg	5290	Mixed DRC Romanée-Saint-Vivant 2011 & 2012	5300
Domaine Georges Roumier, Chambolle-Musigny Les Amoureuses	5312	Mixed DRC Echézeaux & Grands-Echézeaux 1971 & 1976	5301
2005		Mixed DRC Echézeaux & Grands-Echézeaux 2011	5302
Armand Rousseau, Chambertin-Clos-de-Bèze	5238	Mixed DRC Echézeaux & Grands-Echézeaux 2012	5303
Domaine Comte Georges de Vogüe,		Mixed Domaine Georges Roumier,	
Musigny Vieilles Vignes	5246	Bonnes-Mares 1999 & 2004	5313
Domaine de la Romanée-Conti, La Tâche	5280	Mixed Henri Mayer, Echézeaux 1978 & 1981	5346
Domaine de la Romanée-Conti, Romanée-Saint-Vivant	5299	Mixed Henri Mayer, Richebourg 1964 & 1969	5347
Domaine Joseph Roty, Charmes-Chambertin Cuvée de tres Vieilles Vignes	5358	Mixed Formats of Henri Mayer, Richebourg 1978	5348
2006,		Mixed Formats of Henri Mayer, Richebourg 1985	5349
Armand Rousseau, Gevrey-Chambertin Clos Saint-Jacques		Mixed Henri Mayer, Nuits-Saint-Georges Les Meurgers 1980 & 1985 in Magnum	5350
5239		Mixed Henri Mayer, Vosne-Romanée Cros-Parantoux	5351
Domaine de la Romanée-Conti, Romanée-Conti	5264-5265	Mixed Henri Mayer et Georges Mayer,	
2009		Echézeaux 1989, 1991 & 1999	5352
Domaine François Lamarche, La Grande Rue	5307	Mixed J. F. Mugnier, Musigny 1990 & 1993 in Magnums	5354
2010		Mixed Richebourg	5356
Domaine du Comte Liger-Belair, La Romanée	5254	Mixed Clos de La Roche	5359
2011		Mixed Morey-Saint-Denis Clos Sorbés & Gevrey-Chambertin	5360
Domaine de la Romanée-Conti, Romanée-Conti	5266	Mixed Domaine Leroy 2003 & 2005	5362
2012		Mixed Maison Leroy 1955 & 1969	5370
Domaine de la Romanée-Conti, Romanée-Conti	5267	Mixed Clos de Vougeot 1978 & 2001	5371
		Mixed Maison Leroy 1978	5372
MIXED		Mixed Maison Leroy, Savigny-lès-Beaune 1978	5373
Mixed Armand Rousseau 1988 & 1999	5240	Mixed Maison Leroy, Pommard & Volnay 1978	5374
Mixed Armand Rousseau 1990	5241	Mixed Rare Burgundy 1937, 1949 & 1959	5380
Mixed Domaine Comte Georges de Vogüe,		Mixed Volnay Clos de Ducs 1999 &	
Musigny Vieilles Vignes 1952, 1964, 1966 & 1976	5247	Clos de La Roche 2003	5381
Mixed Domaine Comte Georges de Vogüe,			
Musigny Vieilles Vignes 1990, 1993 & 1999	5248	RHÔNE	
Mixed Domaine Comte Georges de Vogüe,		1961	
Chambolle-Musigny Les Amoureuses 1996 & 2004	5250	Maison Paul Jaboulet Aîné, Hermitage La Chapelle	5391-5392
Mixed DRC Romanée-Conti 1991 & 1992	5268	1978	
Mixed DRC Romanée-Conti 1993 & 1994	5269	Château Rayas, Châteauneuf-du-Pape Réserve	5382
Mixed DRC Romanée-Conti 1995 & 1996	5270	E. Guigal, Côte-Rôtie La Landonne	5385
Mixed DRC Romanée-Conti 1997 & 1998	5271	Maison Paul Jaboulet Aîné, Hermitage La Chapelle	5393-5394
Mixed DRC Romanée-Conti 2000 & 2001	5272	1983	
Mixed DRC Romanée-Conti 2002 & 2004	5273	E. Guigal, Côte-Rôtie La Landonne	5386
Mixed DRC La Tâche 1990 & 2003 in Magnum	5281	1985	
Mixed DRC La Tâche 1991, 1992, 1995 & 1996	5282	E. Guigal, Côte-Rôtie La Mouline	5387
Mixed DRC La Tâche 1994, 1995 & 1996	5283	1989,	
Mixed DRC La Tâche 1997 & 1998	5284	Maison Paul Jaboulet Aîné, Hermitage La Chapelle	5395
Mixed DRC La Tâche 2000, 2001 & 2006	5285	1990	
Mixed DRC La Tâche 2011 & 2012,	5286	Château Rayas, Châteauneuf-du-Pape Reserve	5383
Mixed DRC Richebourg 1974 & 1983	5291	Henri Bonneau, Châteauneuf-du-Pape Reserve	
Mixed Formats of DRC Richebourg	5292	des Celestins	5388
Mixed DRC Richebourg 1993 & 1994	5293	J. L. Chave, Hermitage	5389
Mixed DRC Richebourg 1995 & 1996	5294	Maison Paul Jaboulet Aîné, Hermitage La Chapelle	5396-5398
Mixed DRC Richebourg 1997 & 1998	5295	1998,	
*Mixed DRC Richebourg 2000, 2001 & 2005	5296	Domaine du Pegau, Châteauneuf-du-Pape	
Mixed DRC Richebourg 2011 & 2012	5297	Cuvée da Capo	5384

Index by Vintage

WINE	Lot No.	WINE	Lot No.
MIXED			
Mixed J. L. Chave, Ermitage Cuvée Cathelin 1995 & 2000	5390	Mixed Aalto PS 2001 & 2005	5422
Mixed Hermitage La Chapelle 1978 & 1991	5399	Mixed Formats of Aalto PS & Nebro 2001	5423
ITALY			
1961		Mixed Dominio De Pingus 1999 & 2004	5424
Giacomo Conterno, Barolo Monfortino Riserva 1987	5400	Mixed Vega Sicilia Unico 1973, 1974 & 1981 in Magnum	5428
Masseto 1990	5409	Mixed Vega Sicilia Unico 1974, 1976, 1994 & 1995	5429
Ornellaia 1999	5414	Mixed Vega Sicilia Unico 1995 & 1996	5430
Giacomo Conterno, Barolo Monfortino Riserva 2000	5401	PORTUGAL	
Masseto 2001	5410	NV	
Guado Al Tasso	5404	Taylor's Scion	5463
Masseto	5411	1963	
Ornellaia 2002	5415	Quinta do Noval Vintage Port	5460
Solaia	5405-5406	1977	
Ornellaia	5416	Dow's Vintage Port	5461
2009		1994	
Sassicaia	5418	Quinta do Noval Nacional	5462
MIXED			
Mixed Barolo 1967 & 1990	5402	MIXED	
Mixed Formats of Amarone della Valpolicella 1996 & 1998	5403	Mixed Taylor's 1945 & Krohn's 1957 Vintage Port	5459
Mixed Formats of Solaia 1997	5407	USA	
Mixed Antinori, Solaia 2000 & 2001	5408	1994	
Mixed Masseto 1992 & 2002	5412	Dalla Valle Vineyards, Cabernet Sauvignon 1997	5432
Mixed Masseto 1993 & 1997	5413	Dominus	5438
Mixed Ornellaia 1997 & 2002	5417	Joseph Phelps, Insignia 1999	5442
Mixed Formats of Sassicaia 1997 & 1998	5419	Ridge Vineyards, Monte Bello 2001	5444
Mixed Sassicaia in Magnums	5420	Dalla Valle Vineyards, Cabernet Sauvignon	5433
Mixed Sassicaia 2001 & 2002	5421	Dominus	5439
GERMANY			
2005		Shafer Vineyards, Hillside Select 2002	5446
Egon Muller, Scharzhofberger Riesling Trockenbeerenauslese	5431	Dalla Valle Vineyards, Cabernet Sauvignon	5434
SPAIN			
1990		MIXED	
Vega Sicilia Unico 1995	5425	Mixed Harlan Estate 1997 & 1998	5435
Vega Sicilia Unico 1996	5426	Mixed Formats of Harlan Estate 2000	5436
Vega Sicilia Unico	5427	Mixed Harlan Estate 2001 & 2002	5437
		Mixed Formats of Dominus 1983 & 1994,	5440
		Mixed Dominus 1991 & 2003 in Double-Magnum	5441
		Vertical of Opus One	5443
		Mixed Screaming Eagle Cabernet Sauvignon 1993 & 2003	5445
		AUSTRALIA	
		1990	
		Penfolds, Bin 90A	5452
		1996	
		Penfolds, Bin 707	5453

Index by Vintage

WINE	Lot No.
2001	
Torbreck, Descendant	5454
2002	
Torbreck, Run Rig	5455
2003	
Torbreck, Les Amis	5456
Torbreck, The Factor	5457
MIXED	
Mixed Penfolds Grange 1969 & 1971	5447
Mixed Penfolds Grange 1986, 1990, 1992 & 1996	5448
Mixed Penfolds Grange 1993 & 1994	5449
Mixed Penfolds Grange 1996 & 1998	5450
Mixed Formats of Penfolds Grange 2001 & 2006	5451
Mixed Single Vineyard Shiraz & Reserve Pinot Noir	5458

SHORT COURSE IN HONG KONG

Fundamentals of Western Art: From Renaissance to Neoclassicism

25-26 Nov 2016

CHRISTIE'S
EDUCATION | HONG KONG

Sir Peter Paul Rubens (1577-1640)
Lot and His Daughters
1613-1614
Sold for £44,882,500
Christie's London, 7 July 2016

Christie's Education Hong Kong is pleased to present **Fundamentals of Western Art** – a series of programs that aim to provide a broad overview of major artistic movements in the Western world from Renaissance to Contemporary.

Led by Rebecca Lyons, Program Director of Christie's Education London, the first module, **From Renaissance to Neoclassicism**, covers the classical tradition in Europe. Starting from the naturalism and ideals of beauty developed in the Renaissance, the lectures will also cover the drama of Baroque, the sensuality of Rococo, the rationality of Neoclassicism, as well as British portraiture in the 18th century.

This program is essential for art collectors, regardless of their chosen fields, as the works and movements discussed are constantly referred to by artists throughout the ages.

Nov 2016 | Part 1: From Renaissance to Neoclassicism

May 2017 | Part 2: 19th Century in Europe

Nov 2017 | Part 3: European Art: 1900-1949

May 2018 | Part 4: Post-War Art in America and Europe

Location

Hong Kong
Convention and
Exhibition Centre
1 Expo Drive, Wanchai

Fee

HK\$10,000

*(Discounted rate of HK\$9,000
if paid in full by 10 Nov 2016)*

Contact

hongkong@christies.edu
+852 2978 6768
christies.edu/westernart

CONDITIONS OF SALE • BUYING AT CHRISTIE'S

CONDITIONS OF SALE

These Conditions of Sale and the Important Notices and Explanation of Cataloguing Practice set out the terms on which we offer the **lots** listed in this catalogue for sale. By registering to bid and/or by bidding at auction you agree to these terms, so you should read them carefully before doing so. You will find a glossary at the end explaining the meaning of the words and expressions coloured in **bold**.

Unless we own a **lot** (A symbol), Christie's acts as agent for the seller.

A BEFORE THE SALE

1 DESCRIPTION OF LOTS

(a) Certain words used in the catalogue description have special meanings. You can find details of these on the page headed "Important Notices and Explanation of Cataloguing Practice" which forms part of these terms. You can find a key to the Symbols found next to certain catalogue entries under the section of the catalogue called "Symbols Used in this Catalogue".

(b) Our description of any **lot** in the catalogue, any **condition** report and any other statement made by us (whether orally or in writing) about any **lot**, including about its nature or **condition**, artist, period, materials, approximate dimensions or **provenance** are our opinion and not to be relied upon as a statement of fact. We do not carry out in-depth research of the sort carried out by professional historians and scholars. All dimensions and weights are approximate only.

2 OUR RESPONSIBILITY FOR OUR DESCRIPTION OF LOTS

We do not provide any guarantee in relation to the nature of a **lot** apart from our **authenticity warranty** contained in paragraph E2 and to the extent provided in paragraph I below.

3 CONDITION

(a) The **condition** of **lots** sold in our auctions can vary widely due to factors such as age, previous damage, restoration, repair and wear and tear. Their nature means that they will rarely be in perfect **condition**. **Lots** are sold "as is" in the **condition** they are in at the time of the sale, without any representation or warranty or assumption of liability of any kind as to **condition** by Christie's or by the seller.

(b) Any reference to **condition** in a catalogue entry or in a **condition** report will not amount to a full description of **condition**, and images may not show a **lot** clearly. Colours and shades may look different in print or on screen to how they look on physical inspection. **Condition** reports may be available to help you evaluate the **condition** of a **lot**. **Condition** reports are provided free of charge as a convenience to our buyers and are for guidance only. They offer our opinion but they may not refer to all faults, inherent defects, restoration, alteration or adaptation because our staff are not professional restorers or conservators. For that reason they are not an alternative to examining a **lot** in person or taking your own professional advice. It is your responsibility to ensure that you have requested, received and considered any **condition** report.

4 VIEWING LOTS PRE-AUCTION

(a) If you are planning to bid on a **lot**, you should inspect it personally or through a knowledgeable representative before you make a bid to make sure that you accept the description and its **condition**. We recommend you get your own advice from a restorer or other professional adviser.

(b) Pre-auction viewings are open to the public free of charge. Our specialists may be available to answer questions at pre-auction viewings or by appointment.

5 ESTIMATES

Estimates are based on the **condition**, rarity, quality and **provenance** of the **lots** and on prices recently paid

at auction for similar property. **Estimates** can change. Neither you, nor anyone else, may rely on any **estimates** as a prediction or guarantee of the actual selling price of a **lot** or its value for any other purpose. **Estimates** do not include the **buyer's premium** or any applicable taxes.

6 WITHDRAWAL

Christie's may, at its option, withdraw any **lot** at any time prior to or during the sale of the **lot**. Christie's has no liability to you for any decision to withdraw.

7 JEWELLERY

(a) Coloured gemstones (such as rubies, sapphires and emeralds) may have been treated to improve their look, through methods such as heating and oiling. These methods are accepted by the international jewellery trade but may make the gemstone less strong and/or require special care over time.

(b) All types of gemstones may have been improved by some method. You may request a gemmological report for any item which does not have a report if the request is made to us at least three weeks before the date of the auction and you pay the fee for the report.

(c) We do not obtain a gemmological report for every gemstone sold in our auctions. Where we do get gemmological reports from internationally accepted gemmological laboratories, such reports will be described in the catalogue. Reports from American gemmological laboratories will describe any improvement or treatment to the gemstone. Reports from European gemmological laboratories will describe any improvement or treatment only if we request that they do so, but will confirm when no improvement or treatment has been made. Because of differences in approach and technology, laboratories may not agree whether a particular gemstone has been treated, the amount of treatment or whether treatment is permanent. The gemmological laboratories will only report on the improvements or treatments known to the laboratories at the date of the report.

(d) For jewellery sales, **estimates** are based on the information in any gemmological report or, if no report is available, assume that the gemstones may have been treated or enhanced.

8 WATCHES & CLOCKS

(a) Almost all clocks and watches are repaired in their lifetime and may include parts which are not original. We do not give a **warranty** that any individual component part of any watch is **authentic**. Watchbands described as "associated" are not part of the original watch and may not be **authentic**. Clocks may be sold without pendulums, weights or keys.

(b) As collectors' watches often have very fine and complex mechanisms, a general service, change of battery or further repair work may be necessary, for which you are responsible. We do not give a **warranty** that any watch is in good working order. Certificates are not available unless described in the catalogue.

(c) Most wristwatches have been opened to find out the type and quality of movement. For that reason, wristwatches with water resistant cases may not be waterproof and we recommend you have them checked by a competent watchmaker before use.

Important information about the sale, transport and shipping of watches and watchbands can be found in paragraph H2(g).

B REGISTERING TO BID

1 NEW BIDDERS

(a) If this is your first time bidding at Christie's or you are a returning bidder who has not bought anything from any of our salerooms within the last two years you must register at least 48 hours before an auction to give us enough time to process and approve your registration. We may, at our option, decline to permit you to register as a bidder. You will be asked for the following:

(i) for individuals: Photo identification (driving licence, national identity card or passport) and, if not shown on the ID document, proof of your current address (for example, a current utility bill or bank statement);

(ii) for corporate clients: Your Certificate of Incorporation or equivalent document(s) showing your name and registered address together with documentary proof of directors and beneficial owners; and

(iii) for trusts, partnerships, offshore companies and other business structures, please contact us in advance to discuss our requirements.

(b) We may also ask you to give us a financial reference and/or a deposit as a condition of allowing you to bid. For help, please contact our Client Services Department on +852 2760 1766.

2 RETURNING BIDDERS

We may at our option ask you for current identification as described in paragraph B1(a) above, a financial reference or a deposit as a condition of allowing you to bid. If you have not bought anything from any of our salerooms in the last two years or if you want to spend more than on previous occasions, please contact our Bids Department on +852 2978 9910 or email to bidsasia@christies.com.

3 IF YOU FAIL TO PROVIDE THE RIGHT DOCUMENTS

If in our opinion you do not satisfy our bidder identification and registration procedures including, but not limited to completing any anti-money laundering and/or anti-terrorism financing checks we may require to our satisfaction, we may refuse to register you to bid, and if you make a successful bid, we may cancel the contract for sale between you and the seller.

4 BIDDING ON BEHALF OF ANOTHER PERSON

(a) **As authorised bidder:** If you are bidding on behalf of another person, that person will need to complete the registration requirements above before you can bid, and supply a signed letter authorising you to bid for him/her.

(b) **As agent for an undisclosed principal:** If you are bidding as an agent for an undisclosed principal (the ultimate buyer(s)), you accept personal liability to pay the **purchase price** and all other sums due. Further, you warrant that:

(i) you have conducted appropriate customer due diligence on the ultimate buyer(s) of the **lot(s)** in accordance with any and all applicable anti-money laundering and sanctions laws, consent to us relying on this due diligence, and you will retain for a period of not less than 5 years the documentation and records evidencing the due diligence;

(ii) you will make such documentation and records evidencing your due diligence promptly available for immediate inspection by an independent third-party auditor upon our written request to do so. We will not disclose such documentation and records to any third-parties unless (1) it is already in the public domain, (2) it is required to be disclosed by law, or (3) it is in accordance with anti-money laundering laws;

(iii) the arrangements between you and the ultimate buyer(s) are not designed to facilitate tax crimes;

(iv) you do not know, and have no reason to suspect, that the funds used for settlement are connected with, the proceeds of any criminal activity or that the ultimate buyer(s) are under investigation, charged with or convicted of money laundering, terrorist activities or other money laundering predicate crimes.

A bidder accepts personal liability to pay the **purchase price** and all other sums due unless it has been agreed in writing with Christie's before commencement of the auction that the bidder is acting as an agent on behalf of a named third party acceptable to Christie's and that Christie's will only seek payment from the named third party.

5 BIDDING IN PERSON

If you wish to bid in the saleroom you must register for a numbered bidding paddle at least 30 minutes before the auction. For help, please contact the Client Services Department on +852 2760 1766.

6 BIDDING SERVICES

The bidding services described below are a free service offered as a convenience to our clients and Christie's is not responsible for any error (human or otherwise), omission or breakdown in providing these services.

(A) PHONE BIDS

Your request for this service must be made no later than 24 hours prior to the auction. We will accept bids by telephone for **lots** only if our staff are available to take the bids. Telephone bids cannot be accepted for lots estimated below HK\$30,000. If you need to bid in a language other than in English, you must arrange this well before the auction. We may record telephone bids. By bidding on the telephone, you are agreeing to us recording your conversations. You also agree that your telephone bids are governed by these Conditions of Sale.

(B) INTERNET BIDS ON CHRISTIE'S LIVE™

For certain auctions we will accept bids over the Internet. Please visit www.christies.com/livebidding and click on the 'Bid Live' icon to see details of how to watch, hear and bid at the auction from your computer. As well as these Conditions of Sale, internet bids are governed by the Christie's LIVE™ terms of use which are available on www.christies.com.

(C) WRITTEN BIDS

You can find a Written Bid Form at the back of our catalogues, at any Christie's office or by choosing the sale and viewing the **lots** online at www.christies.com. We must receive your completed Written Bid Form at least 24 hours before the auction. Bids must be placed in the currency of the saleroom. The auctioneer will take reasonable steps to carry out written bids at the lowest possible price, taking into account the **reserve**. If you make a written bid on a **lot** which does not have a **reserve** and there is no higher bid than yours, we will bid on your behalf at around 50% of the **low estimate** or, if lower, the amount of your bid. If we receive written bids on a **lot** for identical amounts, and at the auction these are the highest bids on the **lot**, we will sell the **lot** to the bidder whose written bid we received first.

C AT THE SALE

1 WHO CAN ENTER THE AUCTION

We may, at our option, refuse admission to our premises or decline to permit participation in any auction or to reject any bid.

2 RESERVES

Unless otherwise indicated, all **lots** are subject to a **reserve**. We identify **lots** that are offered without **reserve** with the symbol · next to the **lot** number. The **reserve** cannot be more than the **lot's low estimate**.

3 AUCTIONEER'S DISCRETION

The auctioneer can at his sole option:

- refuse any bid;
- move the bidding backwards or forwards in any way he or she may decide, or change the order of the **lots**;
- withdraw any **lot**;
- divide any **lot** or combine any two or more **lots**;
- reopen or continue the bidding even after the hammer has fallen; and
- in the case of error or dispute and whether during or after the auction, to continue the bidding, determine the successful bidder, cancel the sale of the **lot**, or reoffer and resell any **lot**. If any dispute relating to bidding arises during or after the auction, the auctioneer's decision in exercise of this option is final.

4 BIDDING

The auctioneer accepts bids from:

- bidders in the saleroom;
- telephone bidders, and internet bidders through Christie's LIVE™ (as shown above in Section B6); and

(c) written bids (also known as absentee bids or commission bids) left with us by a bidder before the auction.

5 BIDDING ON BEHALF OF THE SELLER

The auctioneer may, at his or her sole option, bid on behalf of the seller up to but not including the amount of the **reserve** either by making consecutive bids or by making bids in response to other bidders. The auctioneer will not identify these as bids made on behalf of the seller and will not make any bid on behalf of the seller at or above the **reserve**. If **lots** are offered without **reserve**, the auctioneer will generally decide to open the bidding at 50% of the **low estimate** for the **lot**. If no bid is made at that level, the auctioneer may decide to go backwards at his or her sole option until a bid is made, and then continue up from that amount. In the event that there are no bids on a **lot**, the auctioneer may deem such **lot** unsold.

6 BID INCREMENTS

Bidding generally starts below the **low estimate** and increases in steps (bid increments). The auctioneer will decide at his or her sole option where the bidding should start and the bid increments. The usual bid increments are shown for guidance only on the Written Bid Form at the back of this catalogue.

7 CURRENCY CONVERTER

The saleroom video screens (and Christie's LIVETM) may show bids in some other major currencies as well as Hong Kong dollar. Any conversion is for guidance only and we cannot be bound by any rate of exchange used. Christie's is not responsible for any error (human or otherwise), omission or breakdown in providing these services.

8 SUCCESSFUL BIDS

Unless the auctioneer decides to use his or her discretion as set out in paragraph C3 above, when the auctioneer's hammer strikes, we have accepted the last bid. This means a contract for sale has been formed between the seller and the successful bidder. We will issue an invoice only to the registered bidder who made the successful bid. While we send out invoices by post and/or email after the auction, we do not accept responsibility for telling you whether or not your bid was successful. If you have bid by written bid, you should contact us by telephone or in person as soon as possible after the auction to get details of the outcome of your bid to avoid having to pay unnecessary storage charges.

9 LOCAL BIDDING LAWS

You agree that when bidding in any of our sales that you will strictly comply with all local laws and regulations in force at the time of the sale for the relevant sale site.

D THE BUYER'S PREMIUM, TAXES

1 THE BUYER'S PREMIUM

In addition to the **hammer price**, the successful bidder agrees to pay us a **buyer's premium** on the **hammer price** of each **lot** sold. On all **lots** we charge 25% of the **hammer price** up to and including HK\$1,200,000, 20% on that part of the **hammer price** over HK\$1,200,000 and up to and including HK\$20,000,000, and 12% of that part of the **hammer price** above HK\$20,000,000.

For wine there is a flat rate of 22.5% of the **hammer price** of each **lot** sold.

2 TAXES

The successful bidder is responsible for any applicable tax including any VAT, sales or compensating use tax or equivalent tax wherever they arise on the **hammer price** and the **buyer's premium**. It is the buyer's responsibility to ascertain and pay all taxes due. In all circumstances Hong Kong law takes precedence.

E WARRANTIES

1 SELLER'S WARRANTIES

For each **lot**, the seller gives a **warranty** that the seller: (a) is the owner of the **lot** or a joint owner of the **lot** acting with the permission of the other co-owners or, if

the seller is not the owner or a joint owner of the **lot**, has the permission of the owner to sell the **lot**, or the right to do so in law; and

(b) has the right to transfer ownership of the **lot** to the buyer without any restrictions or claims by anyone else. If either of the above **warranties** are incorrect, the seller shall not have to pay more than the **purchase price** (as defined in paragraph F1(a) below) paid by you to us. The seller will not be responsible to you for any reason for loss of profits or business, expected savings, loss of opportunity or interest, costs, damages, **other damages** or expenses. The seller gives no **warranty** in relation to any **lot** other than as set out above and, as far as the seller is allowed by law, all **warranties** from the seller to you, and all other obligations upon the seller which may be added to this agreement by law, are excluded.

2 OUR AUTHENTICITY WARRANTY

We warrant, subject to the terms below, that the **lots** in our sales are **authentic** (our "**authenticity warranty**"). If, within 5 years of the date of the auction, you satisfy us that your **lot** is not **authentic**, subject to the terms below, we will refund the **purchase price** paid by you. The meaning of **authentic** can be found in the glossary at the end of these Conditions of Sale. The terms of the **authenticity warranty** are as follows:

(a) It will be honoured for a period of 5 years from the date of the auction. After such time, we will not be obligated to honour the **authenticity warranty**.
(b) It is given only for information shown in **UPPERCASE type** in the first line of the **catalogue description** (the "**Heading**"). It does not apply to any information other than in the **Heading** even if shown in **UPPERCASE type**.

(c) The **authenticity warranty** does not apply to any **Heading** or part of a **Heading** which is **qualified**. **Qualified** means limited by a clarification in a **lot's catalogue description** or by the use in a **Heading** of one of the terms listed in the section titled **Qualified Headings** on the page of the catalogue headed "Important Notices and Explanation of Cataloguing Practice". For example, use of the term "ATTRIBUTED TO..." in a **Heading** means that the **lot** is in Christie's opinion probably a work by the named artist but no **warranty** is provided that the **lot** is the work of the named artist. Please read the full list of **Qualified Headings** and a **lot's full catalogue description** before bidding.

(d) The **authenticity warranty** applies to the **Heading** as amended by any **Saleroom Notice**.

(e) The **authenticity warranty** does not apply where scholarship has developed since the auction leading to a change in generally accepted opinion. Further, it does not apply if the **Heading** either matched the generally accepted opinion of experts at the date of the sale or drew attention to any conflict of opinion.

(f) The **authenticity warranty** does not apply if the **lot** can only be shown not to be **authentic** by a scientific process which, on the date we published the catalogue, was not available or generally accepted for use, or which was unreasonably expensive or impractical, or which was likely to have damaged the **lot**.

(g) The benefit of the **authenticity warranty** is only available to the original buyer shown on the invoice for the **lot** issued at the time of the sale and only if the original buyer has owned the **lot** continuously between the date of the auction and the date of claim. It may not be transferred to anyone else.

(h) In order to claim under the **authenticity warranty** you must:

- give us written details, including full supporting evidence, of any claim within 5 years of the date of the auction;
 - at Christie's option, we may require you to provide the written opinions of two recognised experts in the field of the **lot** mutually agreed by you and us in advance confirming that the **lot** is not **authentic**. If we have any doubts, we reserve the right to obtain additional opinions at our expense; and
 - return the **lot** at your expense to the saleroom from which you bought it in the **condition** it was in at the time of sale.
- (i) Your only right under this **authenticity warranty** is to cancel the sale and receive a refund of the

purchase price paid by you to us. We will not, in any circumstances, be required to pay you more than the **purchase price** nor will we be liable for any loss of profits or business, loss of opportunity or value, expected savings or interest, costs, damages, **other damages** or expenses.

(j) **Books.** Where the **lot** is a book, we give an additional **warranty** for 14 days from the date of the sale that if on collation any **lot** is defective in text or illustration, we will refund your **purchase price**, subject to the following terms:

- (a) This additional **warranty** does not apply to:
 - (i) the absence of blanks, half titles, tissue guards or advertisements, damage in respect of bindings, stains, spotting, marginal tears or other defects not affecting completeness of the text or illustration;
 - (ii) drawings, autographs, letters or manuscripts, signed photographs, music, atlases, maps or periodicals;
 - (iii) books not identified by title;
 - (iv) **lots** sold without a printed **estimate**;
 - (v) books which are described in the catalogue as sold not subject to return; or
 - (vi) defects stated in any **condition** report or **announcement** at the time of sale.
- (b) To make a claim under this paragraph you must give written details of the defect and return the **lot** to the sale room at which you bought it in the same **condition** as at the time of sale, within 14 days of the date of the sale.

(k) **South East Asian Modern and Contemporary Art and Chinese Calligraphy and Painting.**

In these categories, the **authenticity warranty** does not apply because current scholarship does not permit the making of definitive statements. Christie's does, however, agree to cancel a sale in either of these two categories of art where it has been proven the **lot** is a forgery. Christie's will refund to the original buyer the **purchase price** in accordance with the terms of Christie's **authenticity warranty**, provided that the original buyer notifies us with full supporting evidence documenting the forgery claim within twelve (12) months of the date of the auction. Such evidence must be satisfactory to us that the **lot** is a forgery in accordance with paragraph E2(h)(ii) above and the **lot** must be returned to us in accordance with E2h(ii) above. Paragraphs E2(b), (c), (d), (e), (f) and (g) and (i) also apply to a claim under these categories.

(l) **GUARANTEE IN RELATION TO WINES AND SPIRITS**

(a) Subject to the obligations accepted by Christie's, none of the seller, Christie's, its employees or agents is responsible for the correctness of any statement as to the authorship, origin, date, age, attribution, genuineness or provenance of any **lot**, for any other error of description of for any fault or defect in any **lot** and no warranty whatsoever is given by the seller, Christie's, its employees or agents in respect of any **lot** and any express or implied condition or warranty is hereby excluded;

(b) If, (1) within twenty-one days of the date of the auction, Christie's has received notice in writing from the buyer of any **lot** that in his view the **lot** was at the date of the auction short or ullaged or that any statement of opinion in the catalogue was not well founded, (2) within fourteen days of such notice, Christie's has the **lots** in its possession in the same condition as at the date of the auction and (3) within a reasonable time thereafter, the buyer satisfies Christie's that the **lot** was as notified in writing by the buyer (as above) and that the buyer is able to transfer a good and marketable title to the **lot** free from any lien or encumbrance, Christie's will set aside the sale and refund to the buyer any amount paid by the buyer in respect of the **lot** provided that the buyer shall have no rights under this Condition if:

- (i) the defect is mentioned in the catalogue; or
- (ii) the catalogue description at the date of the auction was in accordance with the then generally accepted opinion of scholars or experts or fairly indicated there to be a conflict of such opinion; or
- (iii) it can be established that the **lot** was as notified in writing by the buyer (as above) only by means of a

scientific process not generally accepted for use until after the publication of the catalogue or by means of a process which at the date of the auction was unreasonably expensive or impracticable or likely to have caused damage to the **lot**. (See also notes on ullages and corks);

(c) the buyer shall not be entitled to claim under this Condition for more than the amount paid by him for the **lot** and in particular shall have no claim for any loss, consequential loss or damage whether direct or indirect suffered by him;

(d) the benefit of this guarantee shall not be assignable and shall rest solely and exclusively in the buyer who shall be the person to whom the original invoice was made out by Christie's in respect of the **lot** when sold and who has since the sale retained uninterrupted, unencumbered ownership thereof.

F PAYMENT

1 HOW TO PAY

(a) Immediately following the auction, you must pay the **purchase price** being:

- (i) the **hammer price**; and
- (ii) the **buyer's premium**; and
- (iii) any duties, goods, sales, use, compensating or service tax.

Payment is due no later than by the end of the 7th calendar day following the date of the auction (the "**due date**").

(b) We will only accept payment from the registered bidder. Once issued, we cannot change the buyer's name on an invoice or re-issue the invoice in a different name. You must pay immediately even if you want to export the **lot** and you need an export licence.

(c) You must pay for **lots** bought at Christie's in Hong Kong in the currency stated on the invoice in one of the following ways:

- (i) Wire transfer
- You must make payments to:

HSBC
Head Office
1 Queen's Road, Central, Hong Kong
Bank code: 004
Account No. 062-305438-001
Account Name: Christie's Hong Kong Limited
SWIFT: HSBCHKHHHKH

(ii) Credit Card.

We accept most major credit cards subject to certain conditions. We accept payments in person by credit card up to HK\$1,000,000 per auction sale although conditions and restrictions apply. China Union Pay is accepted with no limits on amounts. To make a "cardholder not present" (CNP) payment, we accept payment up to HK\$500,000 per auction sale. You must complete a CNP authorisation form which you can get from our Post-Sale Services Department. You must send a completed CNP authorisation form by fax to +852 2973 0111 or by post to the address set out in paragraph (d) below. CNP payments cannot be accepted by all salerooms and are subject to certain restrictions. Details of the conditions and restrictions applicable to credit card payments are available from our Post-Sale Services Department, whose details are set out in paragraph (d) below.

(iii) Cash

We accept cash subject to a maximum of HKD80,000 per buyer per year at our Post-Sale Services Department only (subject to conditions).

(iv) Banker's draft

You must make these payable to Christie's Hong Kong Limited and there may be conditions.

(v) Cheque

You must make cheques payable to Christie's Hong Kong Limited. Cheques must be from accounts in Hong Kong dollar from a Hong Kong bank.

(d) You must quote the sale number, your invoice number and client number when making a payment. All payments sent by post must be sent to: Christie's, Post-Sale Services Department, 22nd Floor Alexandra House, 18 Chater Road, Central, Hong Kong.

(e) For more information please contact our Post-Sale Services Department by phone on +852 2760 1766 or fax on +852 2973 0111.

2 TRANSFERRING OWNERSHIP TO YOU

You will not own the **lot** and ownership of the **lot** will not pass to you until we have received full and clear payment of the **purchase price**, even in circumstances where we have released the **lot** to the buyer.

3 TRANSFERRING RISK TO YOU

The risk in and responsibility for the **lot** will transfer to you from whichever is the earlier of the following:

- (a) When you collect the **lot**; or
- (b) At the end of the 7th day following the date of the auction, if earlier, the date the **lot** is taken into care by a third party warehouse as set out on the page headed 'Christie's Hong Kong Wine Collection and Storage', unless we have agreed otherwise with you in writing.

4 WHAT HAPPENS IF YOU DO NOT PAY

(a) If you fail to pay us the **purchase price** in full by the **due date**, we will be entitled to do one or more of the following (as well as enforce our rights under paragraph F5 and any other rights or remedies we have by law):

- (i) to charge interest from the due date at a rate of 7% a year above the 3-month HIBOR rate from time to time on the unpaid amount due;
- (ii) we can cancel the sale of the **lot**. If we do this, we may sell the **lot** again, publicly or privately on such terms we shall think necessary or appropriate, in which case you must pay us any shortfall between the **purchase price** and the proceeds from the resale. You must also pay all costs, expenses, losses, damages and legal fees we have to pay or may suffer and any shortfall in the seller's commission on the resale;
- (iii) we can pay the seller an amount up to the net proceeds payable in respect of the amount bid by your default in which case you acknowledge and understand that Christie's will have all of the rights of the seller to pursue you for such amounts;
- (iv) we can hold you legally responsible for the **purchase price** and may begin legal proceedings to recover it together with other losses, interest, legal fees and costs as far as we are allowed by law;
- (v) we can take what you owe us from any amounts which we or any company in the **Christie's Group** may owe you (including any deposit or other part-payment which you have paid to us);
- (vi) we can, at our option, reveal your identity and contact details to the seller;
- (vii) we can reject at any future auction any bids made by you or on your behalf or to obtain a deposit from you before accepting any bids;
- (viii) to exercise all the rights and remedies of a person holding security over any property in our possession owned by you, whether by way of pledge, security interest or in any other way as permitted by the law of the place where such property is located. You will be deemed to have granted such security to us and we may retain such property as collateral security for your obligations to us; and
- (ix) we can take any other action we see necessary or appropriate.

(b) If you owe money to us or to another **Christie's Group** company, we can use any amount you do pay, including any deposit or other part-payment you have made to us, or which we owe you, to pay off any amount you owe to us or another **Christie's Group** company for any transaction.

(c) If you make payment in full after the **due date**, and we choose to accept such payment we may charge you storage and transport costs from the date that is 35 calendar days following the auction in accordance with paragraphs G(d) (i).

5 KEEPING YOUR PROPERTY

If you owe money to us or to another **Christie's Group** company, as well as the rights set out in F4 above, we can use or deal with any of your property we hold or which is held by another **Christie's Group** company in any way we are allowed to by law. We will only release

your property to you after you pay us or the relevant **Christie's Group** company in full for what you owe. However, if we choose, we can also sell your property in any way we think appropriate. We will use the proceeds of the sale against any amounts you owe us and we will pay any amount left from that sale to you. If there is a shortfall, you must pay us any difference between the amount we have received from the sale and the amount you owe us.

G COLLECTION AND STORAGE

(a) We ask that you collect purchased lots promptly following the auction (**but note that you may not collect any lot until you have made full and clear payment of all amounts due to us**).

(b) Information on collecting **lots** is set out on the Christie's Hong Kong Wine Collection and Storage page.

(c) If you do not collect a **lot** within the period set out in Christie's Hong Kong Wine Collection and Storage page then, unless otherwise agreed in writing:

- (i) we will charge you storage costs from that date.
- (ii) we may sell the **lot** in any commercially reasonable way we think appropriate.
- (iii) Nothing in this paragraph is intended to limit our rights under paragraph F4.

H TRANSPORT AND SHIPPING

1 TRANSPORT AND SHIPPING

We will enclose a transport and shipping form with each invoice sent to you. You must make all transport and shipping arrangements. However, we can arrange to pack, transport and ship your property if you ask us to and pay the costs of doing so. We recommend that you ask us for an **estimate**, especially for any large items or items of high value that need professional packing before you bid. We may also suggest other handlers, packers, transporters or experts if you ask us to do so. For more information, please contact Post-Sale Services Department on +852 2760 1766 or email to postsalesia@christies.com. We will take reasonable care when we are handling, packing, transporting and shipping a **lot**. However, if we recommend another company for any of these purposes, we are not responsible for their acts, failure to act or neglect.

2 EXPORT AND IMPORT

Any **lot** sold at auction may be affected by laws on exports from the country in which it is sold and the import restrictions of other countries. Many countries require a declaration of export for property leaving the country and/or an import declaration on entry of property into the country. Local laws may prevent you from importing a **lot** or may prevent you selling a **lot** in the country you import it into.

(a) You alone are responsible for getting advice about and meeting the requirements of any laws or regulations which apply to exporting or importing any **lot** prior to bidding. If you are refused a licence or there is a delay in getting one, you must still pay us in full for the **lot**. We may be able to help you apply for the appropriate licences if you ask us to and pay our fee for doing so. However, we cannot guarantee that you will get one. For more information, please contact Post-Sale Services Department on +852 2760 1766 or email to postsalesia@christies.com.

(b) Lots made of protected species

Lots made of or including (regardless of the percentage) endangered and other protected species of wildlife are marked with the symbol - in the catalogue. This material includes, among other things, ivory, tortoiseshell, crocodile skin, rhinoceros horn, whalebone certain species of coral, and Brazilian rosewood. You should check the relevant customs laws and regulations before bidding on any **lot** containing wildlife material if you plan to import the **lot** into another country. Several countries refuse to allow you to import property containing these materials, and some other countries require a licence from the relevant regulatory agencies in the countries of exportation as well as importation. In some cases, the **lot** can only be shipped with an

independent scientific confirmation of species and/or age and you will need to obtain these at your own cost. If a **lot** contains elephant ivory, or any other wildlife material that could be confused with elephant ivory, (for example, mammoth ivory, walrus ivory, helmeted hornbill ivory) please see further important information in paragraph (c) if you are proposing to import the **lot** into the USA. We will not be obliged to cancel your purchase and refund the **purchase price** if your **lot** may not be exported, imported or it is seized for any reason by a government authority. It is your responsibility to determine and satisfy the requirements of any applicable laws or regulations relating to the export or import of property containing such protected or regulated material.

(c) US import ban on African elephant ivory

The USA prohibits the import of ivory from the African elephant. Any **lot** containing elephant ivory or other wildlife material that could be easily confused with elephant ivory (for example, mammoth ivory, walrus ivory, helmeted hornbill ivory) can only be imported into the US with results of a rigorous scientific test acceptable to Fish & Wildlife, which confirms that the material is not African elephant ivory. Where we have conducted such rigorous scientific testing on a **lot** prior to sale, we will make this clear in the lot description. In all other cases, we cannot confirm whether a **lot** contains African elephant ivory, and you will buy that **lot** at your own risk and be responsible for any scientific test or other reports required for import into the USA at your own cost. If such scientific test is inconclusive or confirms the material is from the African elephant, we will not be obliged to cancel your purchase and refund the **purchase price**.

(d) Lots of Iranian origin

Some countries prohibit or restrict the purchase and/or import of Iranian-origin "works of conventional craftsmanship" (works that are not by a recognized artist and/or that have a function, for example: carpets, bowls, ewers, tiles, ornamental boxes). For example, the USA prohibits the import of this type of property and its purchase by US persons (wherever located). Other countries, such as Canada, only permit the import of this property in certain circumstances. As a convenience to buyers, Christie's indicates under the title of a **lot** if the **lot** originates from Iran (Persia). It is your responsibility to ensure you do not bid on or import a **lot** in contravention of the sanctions or trade embargoes that apply to you.

(e) Gold

Gold of less than 18ct does not qualify in all countries as 'gold' and may be refused import into those countries as 'gold'.

(f) Watches

(i) Many of the watches offered for sale in this catalogue are pictured with straps made of endangered or protected animal materials such as alligator or crocodile. These **lots** are marked with the symbol - in the catalogue. These endangered species straps are shown for display purposes only and are not for sale. Christie's will remove and retain the strap prior to shipment from the sale site. At some sale sites, Christie's may, at its discretion, make the displayed endangered species strap available to the buyer of the **lot** free of charge if collected in person from the sale site within 1 year of the date of the sale. Please check with the department for details on a particular **lot**.

For all symbols and other markings referred to in paragraph H2, please note that **lots** are marked as a convenience to you, but we do not accept liability for errors or for failing to mark **lots**.

I OUR LIABILITY TO YOU

(a) We give no **warranty** in relation to any statement made, or information given, by us or our representatives or employees, about any **lot** other than as set out in the **authenticity warranty** and, as far as we are allowed by law, all **warranties** and other terms which may be added to this agreement by law are excluded. The seller's **warranties** contained in paragraph E1 are their own and we do not have any liability to you in relation to those **warranties**.

(b) (i) We are not responsible to you for any reason (whether for breaking this agreement or any other matter relating to your purchase of, or bid for, any **lot**) other than in the event of fraud or fraudulent misrepresentation by us or other than as expressly set out in these conditions of sale; or

(ii) give any representation, warranty or guarantee or assume any liability of any kind in respect of any **lot** with regard to merchantability, fitness for a particular purpose, description, size, quality, condition, attribution, authenticity, rarity, importance, medium, provenance, exhibition history, literature, or historical relevance. Except as required by local law, any warranty of any kind is excluded by this paragraph.

(c) In particular, please be aware that our written and telephone bidding services, Christie's LIVE™, condition reports, currency converter and saleroom video screens are free services and we are not responsible to you for any error (human or otherwise), omission, breakdown, or delay, unavailability, suspension or termination of any of these services.

(d) We have no **responsibility** to any person other than a buyer in connection with the purchase of any **lot**.

(e) If, in spite of the terms in paragraphs (a) to (d) or E2(i) above, we are found to be liable to you for any reason, we shall not have to pay more than the **purchase price** paid by you to us. We will not be responsible to you for any reason for loss of profits or business, loss of opportunity or value, expected savings or interest, costs, damages, or expenses.

J OTHER TERMS

1 OUR ABILITY TO CANCEL

In addition to the other rights of cancellation contained in this agreement, we can cancel a sale of a **lot** if we reasonably believe that completing the transaction is, or may be, unlawful or that the sale places us or the seller under any liability to anyone else or may damage our reputation.

2 RECORDINGS

We may videotape and record proceedings at any auction. We will keep any personal information confidential, except to the extent disclosure is required by law. However, we may, through this process, use or share these recordings with another **Christie's Group** company and marketing partners to analyse our customers and to help us to tailor our services for buyers. If you do not want to be videotaped, you may make arrangements to make a telephone or written bid or bid on Christie's LIVE™ instead. Unless we agree otherwise in writing, you may not videotape or record proceedings at any auction.

3 COPYRIGHT

We own the copyright in all images, illustrations and written material produced by or for us relating to a **lot** (including the contents of our catalogues unless otherwise noted in the catalogue). You cannot use them without our prior written permission. We do not offer any guarantee that you will gain any copyright or other reproduction rights to the **lot**.

4 ENFORCING THIS AGREEMENT

If a court finds that any part of this agreement is not valid or is illegal or impossible to enforce, that part of the agreement will be treated as being deleted and the rest of this agreement will not be affected.

5 TRANSFERRING YOUR RIGHTS AND RESPONSIBILITIES

You may not grant a security over or transfer your rights or responsibilities under these terms on the contract of sale with the buyer unless we have given our written permission. This agreement will be binding on your successors or estate and anyone who takes over your rights and responsibilities.

6 TRANSLATIONS

If we have provided a translation of this agreement, we will use the English version in deciding any issues or disputes which arise under this agreement.

7 PERSONAL INFORMATION

We will hold and process your personal information and may pass it to another **Christie's Group** company for use as described in, and in line with, our privacy policy at www.christies.com.

8 WAIVER

No failure or delay to exercise any right or remedy provided under these Conditions of Sale shall constitute a waiver of that or any other right or remedy, nor shall it prevent or restrict the further exercise of that or any other right or remedy. No single or partial exercise of such right or remedy shall prevent or restrict the further exercise of that or any other right or remedy.

9 LAW AND DISPUTES

The rights and obligations of the parties with respect to these Conditions of Sale, the conduct of the auction and any matters connected with any of the foregoing shall be governed and interpreted by the Hong Kong laws. By bidding at auction, whether present in person or by agent, by written bid, telephone or other means, the buyer shall be deemed to have accepted these Conditions and submitted, for the benefit of Christie's, to the exclusive jurisdiction of the Hong Kong courts, and also accepted that Christie's also has the right to pursue remedies in any other jurisdiction in order to recover any outstanding sums due from the buyer.

10 REPORTING ON WWWCHRISTIES.COM

Details of all **lots** sold by us, including **catalogue descriptions** and prices, may be reported on www.christies.com. Sales totals are **hammer price** plus **buyer's premium** and do not reflect costs, financing fees, or application of buyer's or seller's credits. We regret that we cannot agree to requests to remove these details from www.christies.com.

K GLOSSARY

authentic : a genuine example, rather than a copy or forgery of:

- (i) the work of a particular artist, author or manufacturer, if the **lot** is described in the **Heading** as the work of that artist, author or manufacturer;
- (ii) a work created within a particular period or culture, if the **lot** is described in the **Heading** as a work created during that period or culture;
- (iii) a work for a particular origin source if the **lot** is described in the **Heading** as being of that origin or source; or
- (iv) in the case of gems, a work which is made of a particular material, if the **lot** is described in the **Heading** as being made of that material.

authenticity warranty : the guarantee we give in this agreement that a **lot** is **authentic** as set out in section E2 of this agreement.

buyer's premium : the charge the buyer pays us along with the **hammer price**.

catalogue description : the description of a **lot** in the catalogue for the auction, as amended by any saleroom notice.

Christie's Group : Christie's International Plc, its subsidiaries and other companies within its corporate group.

condition : the physical **condition** of a **lot**.

due date : has the meaning given to it paragraph F1(a).

estimate : the price range included in the catalogue or any saleroom notice within which we believe a **lot** may sell. **Low estimate** means the lower figure in the range and **high estimate** means the higher figure. The **mid estimate** is the midpoint between the two.

hammer price : the amount of the highest bid the auctioneer accepts for the sale of a **lot**.

Heading : has the meaning given to it in paragraph E2.

lot : an item to be offered at auction (or two or more items to be offered at auction as a group).

other damages : any special, consequential, incidental or indirect damages of any kind or any damages which fall within the meaning of 'special', 'incidental' or 'consequential' under local law.

purchase price : has the meaning given to it in paragraph F1(a).

provenance : the ownership history of a **lot**.

qualified : has the meaning given to it in paragraph E2 and **Qualified Headings** means the section headed **Qualified Headings** on the page of the catalogue headed 'Important Notices and Explanation of Cataloguing Practice'.

reserve : the confidential amount below which we will not sell a **lot**.

saleroom notice : a written notice posted next to the **lot** in the saleroom and on www.christies.com, which is also read to prospective telephone bidders and notified to clients who have left commission bids, or an announcement made by the auctioneer either at the beginning of the sale, or before a particular **lot** is auctioned.

UPPER CASE type : means having all capital letters.

warranty : a statement or representation in which the person making it guarantees that the facts set out in it are correct.

業務規定

業務規定和重要通知及目錄編列方法之說明列明佳士得拍賣刊載在本目錄中**拍賣品**的條款。

通過登記報投和/或在拍賣會中競投即表示您同意接受這些條款，因此，您須在競投之前仔細閱讀這些條款。下述粗體字體詞語的解釋在尾部詞匯表列明。

除非佳士得擁有**拍賣品**所有權(以▲標示)，佳士得為賣方的代理人。

A. 拍賣之前

1. 拍賣品描述

- 目錄描述部分使用的某些詞匯有特殊意義。詳情請見構成條款部分的重要通知及目錄編列方法之說明。對目錄內的標識的解釋，請見本目錄內“本目錄中使用的各類標識”。
- 本公司在本目錄中對**拍賣品**的描述，**拍賣品狀況**報告及其陳述(不管管口頭還是書面)，包括**拍賣品**性質或**狀況**、藝術家、時期、材料、概略尺寸或**來源**均屬我們意見之表述，而不應被作為事實之陳述。我們不像專業的歷史學家及學者那樣進行深入的研究。所有的尺寸及重量僅為粗略估計。

2. 對於**拍賣品**描述佳士得所負的責任

我們不對**拍賣品**的性質提供任何保证，除了下述第 E2 段的**真品保證**以及第 I 段另有約定。

3. 狀況

- 在我們拍賣會上拍賣的**拍賣品狀況**可因年代、先前損壞、修復、修復及損耗等因素而差異甚大。其性質即意味著幾乎不可能處於完美的**狀況**。**拍賣品**是按其在拍賣之時的情況以“現狀”出售，而且不包括佳士得或賣方的任何陳述或保證或對於**狀況**的任何形式的責任保證。
- 在本目錄條目或**狀況**報告中提及**狀況**不同等同於對**狀況**的完整描述。圖片可能不會清晰顯示出**拍賣品**的色彩和明暗度在印刷品或屏幕上看起來可能會與實體檢查時的情況不同。**狀況**報告可協助您評估**拍賣品**的**狀況**。為方便買方，**狀況**報告為免費提供，僅作為指引。**狀況**報告提供了我們的意見，但是可能未指出所有的缺陷、內在瑕疵、修復、更改及改造，因為我們的僱員不是專業修復或維護人員。出於這個原因，我們不能替代您親自檢查**拍賣品**或您自己專人的專業意見。買方有責任確保自己已經要求提供、收悉及考慮了任何**狀況**報告。

4. 拍賣之前檢查**拍賣品**

- 如果您計劃競投一件**拍賣品**，應親自或通過具有專業知識之代表檢視，以確保您接受**拍賣品**描述之**狀況**。我們建議您從專業修復人員或其他專業顧問那裏索取意見。
- 拍賣之前的檢視免費向公眾開放。在拍賣之前的檢視或通過預約，我們的專家可在場回答問題。

5. 估價

估價是基於**拍賣品**的**狀況**、稀有程度、質量、**來源**及類似物品的近期市場決定。**估價**可能會改變。您或任何其他人任何情況下都不能**估價**，將其作為**拍賣品**的實際售價的預測或保證。**估價**不包括**買方**酬金或任何適用的稅費。

6. 撤回

佳士得有權單方面決定在**拍賣品**拍賣過程中或拍賣之前的任何時間將**拍賣品**撤回。佳士得無須就任何撤回決定向您承擔責任。

7. 珠寶

- 所有寶石(如紅寶石、藍寶石及綠寶石)可能經過處理以改良外觀，包括加熱及上油等方法。這些方法都被國際珠寶行業認可，但是經處理的寶石的硬度可能會降低及/或在日後需要特殊的保養。
- 所有類型的寶石均可經過某些改良處理。如果某件**拍賣品**沒有報告，您可以在拍賣日之前至少提前三周向我們要求寶石鑒定報告。報告的費用由您支付。
- 我們不會為每件拍賣的寶石索取**鑒定報告**。若我們有從國際認可的寶石鑒定實驗室取得**鑒定報告**，我們會在目錄中提及。從美國寶石鑒定實驗室發出的**鑒定報告**會描述對寶石的改良或處理。歐洲寶石鑒定實驗室的報告僅在我們要索取的時候，才會提及對寶石的改良及處理，但是該報告會確認該寶石沒有被改良或處理。因實驗室使用方法和技術的差異，對某寶石是否處理過、處理的程度或處理是否為永久性，都可能不同。寶石鑒定實驗室僅對報告作出日之前實驗室所知悉的改良及處理進行報告。

- 對於珠寶銷售來說，**估價**是以寶石鑒定報告中的信息為基礎。如果沒有報告，就會認為寶石可能已經被處理或提升過。

8. 鐘錶

- 幾乎所有的鐘錶在使用期內都會被修理過，可能都含有非原裝零件。我們不能保證任何鐘錶的任何個別零件都是原裝。被陳述為“關聯”字樣的錶帶不是原裝錶的部分，可能不是**真品**。拍賣的鐘錶可能跟隨帶有鐘錶、鐘錶或鐘錶出售。
- 收藏家等級的錶經常有非常精細複雜的機械構造，可能需要一般保養服務、更換電池或進一步的修理工作，而這些都由買方負責。我們不保證每一隻錶都是在良好運作狀態。除非目錄中有提及，我們不提供證書。
- 大多數的腕錶都被打開過查看機芯的型號及質量。因為這個原因，帶有防水錶殼的腕錶可能不能防水，在使用之前我們建議您讓專業鐘錶師先檢驗。

B. 登記報投

1. 新競投人

- 如果您是您第一次在佳士得競投，或者您曾參與我們的拍賣，但在過去兩年內未曾從任何佳士得拍賣場成功競投過任何東西，您必須在拍賣之前至少 48 小時登記，以給我們足夠的時間來處理及批准您的登記。我們有權單方面不允許您登記成為競投人。您應提供以下資料：
 - 個人客戶：帶有照片的身份證明(駕照執照、國民身份證或護照)，如身份信息文件上没有顯示，您當前的住址證明(如：當前的公共事業賬單或銀行對賬單)。
 - 公司客戶：顯示名稱及注册地址的公司註冊證明或類似文件，以及董事和受益股東的文件證明。
 - 信託、合夥、離業公司及其它業務結構，請提前聯繫我們商談要求。
- 我們可能要求您向我們提供財務證明及/或押金作為許可您競投的條件。如需幫助，請聯繫我們的客戶服務部：+852 2760 1766。

2. 再次參與競投的客人

我們可選擇要求您提供以上 B1(a) 段所提及的現時身份證明、財務證明及/或押金作為許可您競投的條件。如果您過去兩年內沒有從我們的拍賣會成功投得**拍賣品**，或者您本次進出金額高於過往，請聯繫我們的投標部：+852 2978 9910 或電郵至 bidsasia@christies.com。

3. 如果您未能提供正確的資料

如果您認為，您未能滿足我們對競投者身份及登記手續的要求，包括但不限於完成及滿足本公司可能要求進行的所有反洗黑錢和/或反恐衛生義務證書，我們可能會不允許您登記競投。如果您成功投得**拍賣品**，我們可能撤銷您與賣方之間的買賣合約。

4. 代表他人競投

- 作為授權競投人**：如果您代表他人競投，在競投前，委託人需要完成以上的登記手續及提供已簽署的授權書，授權您代表其競投。
- 作為隱名委託人的代理人**：如果您以代理人身份為隱名委託人(最終的買方)進行競投，您同意承擔**拍賣款項**和所有其他應付款項的個人責任。並且，您保證：
 - 您已經根據所有適用的反洗黑錢及制裁法律對**拍賣品**的最終的買方進行必要的客戶盡職調查，同意我們依賴該盡職調查。並且，您將在不於 5 年的期間妥善保存證明盡職調查的文件和記錄。
 - 您在收到我們書面要求後可以將證明盡職調查的文件和記錄立即提供給獨立第三方審計人員即時查閱。我們不會向任何第三方披露上述文件和記錄，除非(1) 它已經在公共領域存在；(2) 根據法律要求須被披露；(3) 符合反洗黑錢法律規定。
 - 您和最終的買方之間的安排不是為了便於任何涉稅犯罪。
 - 您不知曉並且沒有理由懷疑用於結算的資金和任何犯罪收入有關或最終的買方因洗黑錢、恐怖活動或其他基於洗黑錢的犯罪而被調查，被起訴或被定罪。

除非競投人和佳士得在拍賣開始前書面同意競投人僅作為佳士得認可並指定的第三方的代理參與競投並且佳士得只向該指定第三方收取付款，競投人同意繳付**購買款項**和所有其他應付款項個人法律責任。

5. 親自出席競投

如果您希望在拍賣現場競投，必須在拍賣舉行前至少 30 分鐘辦理登記手續，並索取競投號碼牌。如需協助，請聯繫客戶服務部：+852 2760 1766。

6. 競投服務

下述的競投服務是為方便客戶而設，如果在提供該服務出現任何錯誤(人為或其它)，遺漏或故障，佳士得均不負上任何責任。

(A) 電話競投

您必須在拍賣開始前至少 24 小時辦理申請電話競投。佳士得只會在能夠安排人員協助電話競投的情況下接受電話競投。估價低於港幣 30,000 元之**拍賣品**將不接受電話競投。若需要以英語外的其他語言進行競投，須僅在拍賣之前預先安排。電話競投將可被錄音。以電話競投即代表您同意其話被錄音。您同意電話競投受業務規定所限。

(B) 在 Christie's LIVE™ 網絡競投

在某些拍賣會，我們會接受網絡競投。請登入 www.christies.com/liv bidding，點擊“現場競投”圖標，瞭解如何從電腦端體驗及觀看拍賣及參與競投。網絡競投受業務規定及 Christie's Live™ 使用條款的管限，詳情請見 www.christies.com 網站。

(C) 書面競投

您可於本目錄，任何佳士得辦公室或通過 www.christies.com 選擇拍賣並查看**拍賣品**取得書面競投資格。您必須在拍賣開始前至少 24 小時提交已填妥的書面競投表格。投標必須是以拍賣會當地的貨幣為單位。拍賣官將在參考**底價**後，合理地履行書面競投請求以可能的最低價價行使書面競投。如果您以書面投一件沒有**底價**的**拍賣品**，而且沒有其他更高叫價，我們為您以**最低估價**的 50% 進行競投；或如果您書面的叫價比上述更低，則以您的書面的價格進行競投。如果您傳收到多個競投價格相等的書面競投，而在拍賣時此等競投價格乃該**拍賣品**之最高出價，則該**拍賣品**售給最先遞交其書面競投書給本公司之競投人。

3. 拍賣之時

1. 進入拍賣現場

我們不允許任何人士進入拍賣場地，參與拍賣，亦可拒絕接受任何競投。

2. 底價

除非另外列明，所有**拍賣品**均有**底價**。不定有**底價**的**拍賣品**，在**拍賣品**號碼旁選用-標記，**底價**不會高於**拍賣品**的**低價估價**。

3. 拍賣官之酌情權

拍賣官可以酌情選擇：

- 拒絕接受任何競投；
- 以具決定方式將競投提前或拖後，或改變**拍賣品**的順序；
- 撤回任何**拍賣品**；
- 將任何**拍賣品**分開拍賣或將兩件或多件**拍賣品**合併拍賣；
- 重開或繼續競投，即變更下號；
- 如果有出錯或爭議，無論是在拍賣時或拍賣後，選擇繼續拍賣、決定繼續成功競投人、取消**拍賣品**的拍賣或將**拍賣品**重新拍賣或出售。在拍賣之時或後對競投有任何爭議，拍賣官有最終決定權。

4. 競投

拍賣官接受以下競投：

- 拍賣會場參與競投的競投人；
- 從**電話競投人**，通過 Christie's Live™ (如第 B6 部分所示) 透過網絡競投的競投人；
- 拍賣之同時提交佳士得的書面競投(也稱為不在場競投或委託競投)。

5. 代表賣方競投

拍賣官可選擇代表賣方競投的方式連續競投或以回應其他競投者的投標而競投的方式，直至達到**底價**以下。拍賣官不會特別指明此乃代表賣方的競投。拍賣官不會代表賣方作出等於或高於**底價**之出價。就不設**底價**的**拍賣品**，拍賣官通常會以**低價估價**的 50% 開始投標。如果在該此價位沒有人競投，拍賣官可以自行將拍賣價格下降繼續拍賣，直至有人競投，然後從該價位向上拍賣**拍賣品**。如果無人競投該**拍賣品**，拍賣官可視該**拍賣品**為**拍賣品**。

6. 競投價遞增幅度

競投通常會從低於**低價估價**開始，然後逐步增加(競投價遞增幅度)。拍賣官會自行決定競投開始價位及遞增幅度。本目錄內的書面競投表格上顯示的一般遞增幅度，僅供閣下參考。

7. 貨幣兌換

拍賣會的顯示板 (Christie's Live™) 可能會以港幣及其它主要貨幣來展示該投標。任何兌換率僅作指引，佳士得並不受其約束。對於在提供該服務出現的任何錯誤 (人為或其它)，遺漏或故障，佳士得並不負責。

8. 成功競投

除非拍賣官決定使用以上 C3 段中的酌權，拍賣官下壓即表示對最終競投價之接受。這代表賣方和成功競投人之間的買賣合約之訂立。我們僅向已登記的成功競投人開具發票。拍賣後我們會以郵寄及/或電子郵件方式發送發票，但我們並不負責通知閣下競投是否成功。如果您以書面競投，拍賣後您應儘快以電話聯繫我們或親臨本公司查詢競投結果，以避免產生不必要的倉儲費用。

9. 競投地法律

當您在我們的拍賣中競投時，您同意您會嚴格遵守所有在拍賣時生效並適用於相關拍賣場所的當地法律及法規。

D. 買方佣金及稅款

1. 買方佣金

成功競投人除支付**成交價**外，亦同意支付本公司以該**拍賣品成交價**計算的**買方佣金**。佣金率按每件**拍賣品成交價**至港幣1,200,000元之25%、加逾港幣1,200,000元以上至港幣20,000,000元部分之20%、加逾港幣20,000,000元以上之12%計算。

名酒的**買方佣金**是按每件**拍賣品成交價**之22.5%。

2. 稅費

成功競投者將負責所有適用**拍賣品稅費**，包括增值稅、銷售或補償使用稅費或者所有基於**成交價**和**買方佣金**而產生的稅費。買方有責任查明並支付所有應付稅費。在任何情況下香港法律先方適用。

E. 保證

1. 買方保證

對於每件**拍賣品**，買方保證其：

- 為**拍賣品**的所有人，或**拍賣品**的共同人之一並獲得其他共有人的許可；或者，如果賣方不是**拍賣品**的所有人或其他共有人之一，其已獲得所有人的授權出售**拍賣品**或其任法律上有權處置；
- 有權利將**拍賣品**的所有權轉讓給買方，且該權利不負擔任何限制或任何其他人的索賠。

如果以上任何**保證**不確實，買方不必支付超過您已向我們支付的**購買款項** (詳見以下第 F1(a) 段定義) 的金額。賣方不會就關連利潤上或經營的損失、預期存款、商標喪失或利息的損失、成本、賠償金、**其他賠償**或支出承擔責任。買方不就此任何**拍賣品**提供任何以上列舉之外的**保證**；只要法律許可，所有賣方對您作出的**保證**及法律要求加入本協議的所有其它賣方責任均被免除。

2. 真品保證

在不抵觸以下條款的情況下，本公司保證我們**拍賣品**都是**真品** (我們的**“真品保證”**)。如果在拍賣日後的五年內，您使我們滿意您的**拍賣品**不是**真品**，或在符合以下條款規定之下，我們將把您支付的**購買款項**退還給您。業務規定的詞匯表裏對**“真品”**一詞做出解釋。**真品保證**條款如下：

- 我們在拍賣日後的5年內提供**真品保證**。此期限過後，我們不再提供**真品保證**。
- 我們只會對本目錄描述第一行 (“**標題**”) 以**大贈字體**注明資料作出**真品保證**。除了**標題**中顯示的資料，我們不對任何**標題**以外的資料 (包括**標題**以外的大贈字體注明) 作出任何**保證**。
- 真品保證**不適用於**有保留標題**或有**保留**的部分**標題**。**有保留**是指受限於**拍賣目錄**描述內的解釋，或者**標題**中有“重要通告及目錄編列方法之說明”內有**有保留標題**的某些字眼。例如：**標題**中對“認為是...之作品”的使用指佳士得認為**拍賣品**可能是某位藝術家的作品，但是佳士得不保證該作品一定是該藝術家的作品。在競投前，請閱覽“**有保留標題**”列表及**拍賣品**的**目錄描述**。
- 真品保證**適用於於**拍賣會通告**訂下的**標題**。
- 真品保證**不適用於在拍賣之後，學術發展導致被普遍接受的學者或專家意見有所改變。此保證亦不適用於在拍賣日期，**標題**乎被普遍接受的學者或專家的意見，或**標題**指出意見衝突的地步。
- 如果**拍賣品**只有通過科學鑒定方法才能鑒定出不是**真品**，而在我們出版目錄之日，該科學方法未存在或未被普遍認可，或價格太高或不實際，或者可能損壞**拍賣品**，則**真品保證**不適用。
- 真品保證**僅適用於**拍賣品**在拍賣時由佳士得發出之發票之原本賣方，且僅在原本賣方在拍賣日與申索之日持續擁有該**拍賣品**才適用。保證中的利益不可以轉讓。

(h) 要申索**真品保證**下的權利，您必須：

- 在拍賣日後5年內，向我們提供書面的申索通知並提供詳情，包括完整的佐證證據；
- 佳士得有權要求您提供佳士得及您均事先同意的在此**拍賣品**領域被認可的兩位專家的書面意見，確認該**拍賣品**不是**真品**。如果我們有任何疑問，我們保留自己支付費用獲取更多意見的權利；及
- 自費交回與拍賣時狀況相同的**拍賣品**給佳士得**拍賣場**。

(i) 您在**本真品保證**下唯一的權利就是取消該項**拍賣**及取回已付的**購買款項**。在任何情況下我們不須支付您超過您已向我們支付的**購買款項**的金額，同時我們也無須對任何利潤或經營損失、商標或價值喪失、預期存款或利息、成本、賠償金或**其他賠償**或支出承擔責任。

(j) **書畫**。如果**拍賣品**為書畫，我們提供額外自拍賣日起為期14天的**保證**，如經校對後，我們將您的文本或圖樣存有瑕疵，在以下條款的規限下，我們將退回已付的**購買款項**：

- 此類**保證**不適用於：
 - 缺少空白頁、扉頁、保護頁、廣告、及書籍鑲邊的破損、污漬、邊緣磨損或其它不影響文本及圖樣完整性的瑕疵；
 - 繪圖、簽名、書信或手稿；帶有簽名的照片、音樂唱片、地圖冊、地圖或期刊；
 - 沒有標題的書籍；
 - 沒有標明**估價**的已出售**拍賣品**；
 - 目錄中表明售出後不可退貨的書籍；
 - 狀況報告中或拍賣時公告的瑕疵。
- 要根據本條規定申索權利，您必須在拍賣後的14天內就有關瑕疵提交書面通知，並交回與拍賣時狀況相同的**拍賣品**給當時進行拍賣的佳士得**拍賣場**。

(k) 東南亞現代及當代藝術以及中國書畫

真品保證並不適用於此類**拍賣品**。目前學術界不容許對此類別作出確實之說明，但佳士得無須取消被證實為偽品之東南亞現代及當代藝術以及中國書畫**拍賣品**之交易。已付之**購買款項**則根據佳士得**真品保證**的條款退還予原本賣方，但買方必須在拍賣日起12個月內以書面通知本公司有關**拍賣品**為偽品並能按以上 E2(ii)(h) 的規定提供令佳士得滿意的證據，證實該**拍賣品**為偽品，及須按照以上 E2(i)(ii) 規定交回**拍賣品**給我們。E2(b), (c), (d), (e), (f), (g) 及 (i) 適用於此類別之申索。

(l) 有關名酒及烈酒**保證**

(a) 佳士得所接受的責任所限，賣方、佳士得、其員工或代理人均無須對有關任何貨批的任何聲明的出處、來源、日期、年份、屬性、真實性或出處之正確性負責。賣方對任何其他錯誤說明及**拍賣品**的缺陷或損毀亦無須負責。而賣方、佳士得、其員工或代理人均不對對任何**拍賣品**作出**保證**，並在以此排除任何明示或默示的狀況或**保證**。

(b) 如果，(1) 在拍賣日期的二十一日前，佳士得收到買方對任何**拍賣品**的書面通知，在競投當日買方觀察到**拍賣品**的水位不足或有自然耗損或目錄中任何意見的聲明並未有良好事實基礎，(2) 在收到有關通知的十四日內，佳士得擁有之**拍賣品**與競投當日的狀況相同，及(3) 在期後的一段合理時間內，買方令佳士得確信有關**拍賣品**如上述及方的書面通知的情況，而賣方能夠在無任何保留權及妨礙下轉讓有關**拍賣品**的擁有權，佳士得將會撤銷賣出與買方退還賣方支付有關**拍賣品**的所有款項。如出現以下情況，買方將無本條款所載之權利：

- 該損毀已在目錄中提及；或
- 在競投當日目錄的說明已符合學者或專家作出的一般被接納的意見，或該說明已公正地顯示有關意見會有分歧；或
- 不可憑在目錄印行前仍通常不被採用的科學程序之方法，或採用在競投當日是不合理地昂貴或不可行的程序之方法，或可能損毀**拍賣品**的方法，才可查**拍賣品**及當時的情況如上述及方的書面通知的情況。(請參閱耗損及酒蓋的說明)；

(c) 買方不可根據此條件索償高於該**拍賣品**所支付的金額，也不得就任何其直接或間接遭受之損失、附帶損失或損壞作出索償；

(d) 此項**保證**之利益不得轉讓，且**拍賣品**出售時佳士得向其發原有提貨單之買方全權及絕對擁有，買方於出售後一直維持擁有權，買方的擁有權從來未曾中斷或被用作抵押或擔保用途。

F. 付款

1. 付款方式

- 拍賣後，您必須立即支付以下**購買款項**：
 - 成交價；和
 - 買方佣金；和
 - 任何關稅、有關貨物、銷售、使用、補償或服務稅項。所有款項須於拍賣後7個日曆天內悉數付清 (“**到期付款日**”)。

(b) 我們只接受受託競投人付款。發票一旦開具，發票上買方的姓名不能更換，我們亦不能以不同姓名重新開具發票。即使您欲將**拍賣品**出口且需要出口許可證，您也必須立即支付以上款項。

(c) 在香港下列之**購買品**，您必須按照發票上顯示的貨幣以下列方式支付：

- 電匯至：
香港上海匯豐銀行總行
香港中環皇后大道中1號
銀行編號：004
賬號：062-305438-001
賬名：Christie's Hong Kong Limited
匯款銀行代號：HSBKHKHHKX
- 信用卡

在符合我們的規定下，我們接受各種主要信用卡付款。本公司每次**拍賣**接受受總款不超過港幣1,000,000元之現場信用卡付款，但有關係款及限制適用。以中國銀聯支付方式沒有金額限制。如每次以“持卡人不在場”(CNP) 的方式支付，本公司每次**拍賣**接受受總款不超過港幣500,000元之付款。您必須填妥 CNP 授權表格，該表格可向我們索取，請將已填妥之 CNP 授權表格以傳真 (+852 2973 0111) 或以郵寄方式發送到以下 (d) 段的地址。CNP 付款不適用於所有佳的**拍賣場**，並受某些限制。適用於信用卡付款的條款和限制可從佳士得的售後服務部獲取，詳情列於以下 (d) 段：

- 現金
本公司每年只接受每位買方總款不超過港幣80,000元之現金付款 (須受有關條件約束)；
- 銀行匯票
抬頭請註明“佳士得香港有限公司” (須受有關條件約束)；
- 支票
抬頭請註明“佳士得香港有限公司”。支票必須於香港銀行兌現並以港幣支付。
- 支付時請註明**拍賣編號**、發票號碼及客戶號碼；以郵寄方式支付必須發送到：佳士得香港有限公司，售後服務部 | 地址：香港中環遮打道18號匯豐大廈22樓)。
- 如要瞭解更多信息，請聯繫售後服務部。電話 +852 2760 1766；傳真：+852 2973 0111。

2. 所有權轉移

只有我們自您處收到全額且清償**購買款項**後，您才擁有**拍賣品**及**拍賣品**的所有權，即使本公司已將**拍賣品**交還您。

3. 風險轉移

拍賣品的風險和責任自以下日期起將轉移給您 (以較早者為準)：

- 賣方填貨日；
- 自拍賣日起計7日後，如較早，則**拍賣品**根據“香港佳士得名酒倉存及提取及儲存”頁由第三方倉庫保管之日起；除非另行協議。

4. 不付款之補救辦法

- 如未到期**付款日**，您未能全數支付**購買款項**，我們將有權行使以下一項或多項 (及執行我們在 F5 段的權利或以法律賦予我們的其它權利或補救辦法)：
 - 自**到期付款日**起，按照尚欠款項，收取高於香港金融管理局不時公布的三個月銀行同業拆息加7%的利息；
 - 取消交易並按照我們認為合適的條件對**拍賣品**公開重新**拍賣**或私下重新售賣。您必須向我們支付原來您應支付的**購買款項**與再次**拍賣**或之間的差額。您也必須支付必須支付或可能蒙受的一切成本、費用、損失、賠償、法律費用及任何買方佣金之差額；
 - 不進行責任的買方支付賣方應付的**購買款項**金額。您承認佳士得擁有**拍賣品**之所有權利向您提出追討；
 - 您必須承擔尚欠之**購買款項**，我們可取回超出此金額而向您提出法律訴訟程序及在法律許可下向您索回之其他損失、利息、法律費用及其他費用；
 - 將我們或佳士得保留任何公司欠下您之款項 (包括您已付給我們之任何保證金或部分付款) 用以抵銷您未付之款項；
 - 我們將以選擇將您的身份及聯繫方式披露給買方；
 - 在將任何**拍賣品**中，不允許您或您的代表作出競投，或在接受您競投之前向您收取保證金；
 - 在**拍賣品**所處地方之法律許可之下，佳士得就您擁有或由佳士得管有的**拍賣品**或以抵押品並以抵押品與他人身份行使最高程度之權利及補救方法，不論是與典當方式、抵押方式或任何其他形式。您則被視為已授與本公司該等抵押及本公司可保留或轉讓此物品作為買方對本公司及賣方的附屬抵押責任；和
 - 採取我們認為必要或適當的任何行動。

- b) 將您已付的款項，包括保證金及其他部份付款或我們欠您的款項用以抵銷您欠我們或其他**佳士得集團公司**的款項。
- c) 如果您在**到期付款日**之後支付全部款項，同時，我們選擇接受該付款，我們可以自拍賣後第 35 日起根據 G(c) 段向您收取倉儲和運輸費用。

5. 扣押拍賣品

如果您欠我們或其他**佳士得集團公司**款項，除了以上 F4 段的權利，在法律許可下，我們可以以任何方式使用或處置您欠於我們或其他**佳士得集團公司**的**拍賣品**。只有您完全繳付欠於我們或相關**佳士得集團公司**的全部款項後，您方可領回有關**拍賣品**。我們可選擇將您的**拍賣品**按照我們認為適當的方式出售。我們將用出售**拍賣品**的銷售所得來抵銷您欠我們的任何款項，並支付我們任何剩餘部分。如果銷售所得不足以抵償，您須支付差額。

G. 提取及倉儲

- (a) 我們要求您在拍賣之後立即提取您購買的**拍賣品**（但請注意，在全數付清所有款項之前，您不可以提取**拍賣品**）。
- (b) 有關提取**拍賣品**之詳情已列明於「香港佳士得各港區提取及儲存」頁。
- (c) 買方若未能於「香港佳士得名酒提取及儲存」頁列明的期限內提取**拍賣品**，除非另有書面約定：
- 我們將從當日起收取倉儲費。
 - 我們可以按我們認為商業上合理且恰當的方式出售**拍賣品**。
 - (iii) 本段的任何內容不限制我們在 F4 段下的權利。

H. 運送

1. 運送

運送或付運包裹與發票一同發送給您。您須自行安排**拍賣品**的運送和付運事宜。我們也可以依照您的要求安排包裝運送及付運事宜，但您須支付有關收費。我們建議您在發件前預先查詢有關收費的估價，尤其是需要專業包裝的大件物品或高價值品。您應要求，我們也應建議處理、包裝、運輸公司或有關專家。

詳情請聯繫**佳士得**後服務部，電話：+852 2760 1766 或發郵件至 postalesia@christies.com。我們會合理處理和包裝、運輸**拍賣品**。若我們就上述目的向您推薦任何其他公司，我們不會承擔有關公司之行為、遺漏或疏忽引起的任何責任。

2. 出口 / 進口

拍賣售出的任何**拍賣品**都可能受**拍賣品**售出國家的出口法律及其他國家的進口法律限制。許多國家要求**拍賣品**出口時需明發及 / 或就**拍賣品**入境要求進口證明。進口國當地法律可能禁止運送進口某些**拍賣品**或禁止**拍賣品**在進口國出售。

- (a) 在競投前，您應尋求專業意見並確保滿足任何法律或法規對出口或進口**拍賣品**的要求。如果您被拒絕許可證，或申請許可證延誤，您仍須全數支付**拍賣品**的款項。如果您提出請求，在我們能力範圍許可內，我們可以協助您申請所需許可證，但我們會就此服務向您收取費用。我們不保證必能獲得許可證。如欲了解詳情，請聯繫**佳士得**後服務部，電話：+852 2760 1766 或發郵件至 postalesia@christies.com。

(b) 含有受保護動物標的**拍賣品**

由瀕臨絕種及其他受保護野生動物製成或組成（不論佔比比率）的**拍賣品**在本目錄中註有 [-] 號。這些物品包括但不限於象牙、玳瑁殼、鱷魚皮、犀牛角、鯨骨、某些珊瑚標本及巴西玫瑰木。若您有意將含有野生動物標的的任何**拍賣品**出口至其他國家，您應於競投**拍賣品**之前了解有關海關法律和規定。有些國家完全禁止含有這類動物的物品進口，而其他國家則規定須向出口及入口國家的有關管理機構取得許可證。在有些情況下，**拍賣品**必須附有獨立刊印的物種科學證明和 / 或年期證明，方能裝運，而您須要自行安排上述證明並負責支付有關的費用。如果一件**拍賣品**含有象牙或其他可能和象牙相混淆的野生動物標的（例如猛犸象牙，海象象牙和犀牛角牙）且您計劃將上述**拍賣品**運送到美國，請查看(c)段中之重要信息。如果您無法出口，進口該**拍賣品**或因任何原因**拍賣品**被政府部門查收，我們沒有義務因此取消您的交易並退回您的**購買款項**。您應負責確定並滿足有關含有上述動物**拍賣品**進出口的法律和規例要求。

(c) 美國關於非洲象象牙的進口禁令

美國禁止非洲象象牙進口美國。如果一件**拍賣品**含有象牙或其他可能和象牙相混淆的野生材料（例如猛犸象牙，海象象牙和犀牛角牙），其必須通過受美國漁業和野生動物保護局認可的嚴格科學測試確認該物種非非洲象象牙方可進口美國。如果我們在拍賣前對**拍賣品**已經進行了該嚴格科學測試，我們會在**拍賣品**陳述中清楚表明。我們一經無法確認**拍賣品**的象牙是否來自非洲象。您凡購買有關**拍賣品**並計畫將有關**拍賣品**進口美國，必須承擔風險並

負責支付任何科學測試或其他報告的費用。有關測試並無定論或確定物種非非洲象象牙，不被視為取消拍賣和退回**購買款項**的依據。

(d) 源自伊朗的**拍賣品**

一些國家禁止或限制購買和 / 或進口源自伊朗的“傳統工藝作品”（身份不明確的藝術家作品及 / 或功能性作品。例如：地毯、碗、大口水壺、瓷磚和裝飾盒）。美國禁止進口以上物品亦禁止美國民眾（不論所在處）購買以上物品。有些國家，例如加拿大則允許在某特定情況下可以進口上述物品。為方便買方，佳士得在源自伊朗（波斯）的**拍賣品**下方特別註明，如您受以上制裁或貿易禁運限制，您須確保您不會競投或進口有關**拍賣品**，違反有關適用條例。

(e) 黃金

含量低於 18k 的黃金並不是在所有國家均被視為“黃金”，並可能被拒絕入口。

(f) 鐘錶

- (i) 本目錄內有些鐘錶的照片顯示手錶配有滿倉及受保護動物（如短吻鱷或鱷魚）的物料所製成的錶帶。這些**拍賣品**在本目錄內的**拍賣品**編號旁，以符號顯示。這些錶帶只用來展示**拍賣品**並不作銷售用途。在運送手錶到拍賣地以外的地點前，佳士得會把上述錶帶拆除並予以保存。買方若在拍賣後一年內親身到貨物所在地佳士得提取，佳士得可酌量免費提供錶帶給買方，但含有滿倉及受保護動物標的錶帶給買方。
- H2 段中的標記是佳士得為了方便閣下在有關**拍賣品**附近的，附加標記時如有任何錯誤或遺漏，佳士得恕不承擔任何責任。

I. 佳士得之法律責任

- (a) 除了**真品保證**，佳士得、佳士得代理人或僱員，對任何**拍賣品**作任何陳述，或資料的提供，均不作出任何**保證**。在法律容許的最大限度下，所有由我們附加的保證及其他條款，均被排除在本協議之外。在 E1 段中的賣方保證是由賣方提供的保證，我們對這些**保證**不負有任何責任。

- (b) (i) 除非我們以欺詐手段作出有欺詐成份的失實陳述或在本業務規定中有明確證明，我們不會因任何原因對您負有任何責任（無論是因違反本協議，購買**拍賣品**或與競投相關的任何其他事項）；或 (ii) 賣方、本公司、本公司之僱員或代理人均無就任何**拍賣品**的可商售品質，是否適合其特定用途、描述、尺寸、質量、狀況、作品歸屬、真實性、稀有程度、重要性、媒介、來源、展覽歷史、文獻或歷史的關聯等作出任何陳述、保證或擔保或承擔任何責任。除非非當地的法律強制要求，任何種類的任何**保證**，均被本條排除在外。

- (c) 請注意佳士得所提供的書面競投及電話競投服務、Christie's Live™、狀況報告、貨幣兌換顯示板及拍賣室錄像影像為**免費**服務。如有任何錯誤（人為或任何其他原因）、遺漏或故障或延誤，未能提供、暫停或終止，本公司不負任何責任。

- (d) 就**拍賣品**購買的事實，我們僅對賣方負有法律責任。
- (e) 如果儘管有(a)至(d)或 E2(i)段的規定，我們因某些原因須對您負上法律責任，我們不須支持超過您已支付的**購買款項**。佳士得不須就任何利潤或經營支出、商機喪失或價值、預期存款或利息、費用、賠償或支出等因您負上任何責任。

J. 其他條款

1. 我們的撤銷權

除了本協議中的其他撤銷權利，如果我們合理地認為完成交易可能是違法行為或該銷售會令我們或賣方向任何他人負上法律責任或損壞我們的名譽，我們可取消該**拍賣品**的拍賣。

2. 錄像

我們可以錄影及記錄**拍賣**過程。除非按法律要求，我們會對個人信息加以保密。該資料可能用於或提供其他**佳士得集團公司**和市場夥伴以作客戶分析或以便我們向賣方提供合適的服務。若您不想被錄影，您可透過電話或書面競投或在 Christie's LIVE™ 競投。除非另有書面約定，您不能在拍賣現場錄像或錄影。

3. 版權

所有由佳士得或為佳士得與**拍賣品**有關之製作之一切圖冊、插圖與書面資料（除有特別注明外，包括我們的目錄的內容）之版權均屬於佳士得所有。沒有我們的書面許可不得使用以上版權作品。我們沒有保證您就取得的**拍賣品**會取得任何版權或其他複製的權利。

4. 效力

如本協議的任何部份因任何法院認定為無效、不合法或無法執行，則該部分應被視為刪除，其它部分不受影響。

5. 轉讓您的權利及責任

除非我們給予書面許可，否則您不得就您在本協議下的權利或責任設立任何抵押，亦不得轉讓您的權利和責任。本協議對您的繼任人、遺產及任何承繼閣下責任的人具有約束力。

6. 翻譯

如果您提供了本協議的翻譯件，我們將會使用英文版用於解決本協議下產生的任何問題以及爭議。

7. 個人信息

您同意我們將持有並處理您的個人數據或信息，並將其交給其它**佳士得集團公司**用於我們的私隱政策所描述的目的，或與其相符的目的。您可以在 www.christies.com 上找到本公司私隱政策。

8. 棄權

未能或延遲行使本業務規定下的權利或補償不應被視為免除該權利或補償，也不應阻止或限制對該權利或補償或其他權利或補償的行使。棄權或部分行使該權利或補償不應阻止或限制對其它權利或補償的行使。

9. 法律及管轄權

各方的權利及義務，就有關本業務規定，拍賣的行為及任何與上述條文的事項，均受香港法律管轄及根據香港法律解釋。在拍賣競投時，無論是親自出席或由代理人出席競投，書面、電話及其他方法競投，買方即被視為接受本業務規定，及為佳士得之利益而言，接受香港法院之排他性管轄權，並同時接納佳士得亦有權在任何其他司法管轄區提出索償，以追討買方拖欠的任何款項。

10. www.christies.com 的報告

售出的**拍賣品**的所有資料，包括目錄描述及價款都可在 www.christies.com 上查閱。銷售總額成交價加上買方酬金，其不反映本金、財務費用或買方或賣方信貸申請情況。我們不能按要求將這些資料從 www.christies.com 網站上刪除。

K. 詞彙表

- 以下所述的真實作品，而不是複製品或仿品：
- 拍賣品**在標題被描述為某位藝術家、作者或製作者的作品，則為該藝術家、作者或製造者的作品；
 - 拍賣品**在標題被描述為是某時期或流派創作的作品，則該時期或流派的作品；
 - 拍賣品**在標題被描述為某來源，則為該來源的作品；
 - 以寶石為例，如**拍賣品**在標題被描述為由某種材料製成，則該作品是由該材料製成。

真品保證：我們在本協議 E 段所述述為**拍賣品**提供的保證。

目錄描述：除了**成交價**，買方支付給我們的費用。

賣方酬金：拍賣目錄內對**拍賣品**的陳述（包括於拍賣場通過對有關陳述作出的任何更改）。

佳士得集團：Christie's International Plc、其子公司及集團的其它公司。

拍賣品的物狀況。

到期付款日：如第 F(a) 段所列出的意思。

估價：目錄中或拍賣場通告中列明的我們認為**拍賣品**可能出售的價格範圍。低端估價指該範圍的最低值；高端估價指該範圍的最高值。中間估價為兩者的中間點。

成交價：拍賣官接受的**拍賣品**最高競投價。

標題：如 E2 段所列出的意思。

拍賣品：供拍賣的一件**拍賣品**（或作為一組拍賣的兩件或更多的物件）；

其他賠償：任何特殊、連帶、附帶或間接的賠償或任何符合當地法律規定的“特殊”、“附帶”或“連帶”賠償。

購買款項：如第 F1(a) 段的意思。

來源：**拍賣品**的所有權歷史。

有保留：如 E2 段中的意思；**有保留**標題則指目錄中“重要通知和目錄編制說明”頁中的“有保留標題”的意思。

底價：**拍賣品**不會以低於此底價出售。

拍賣場通告：張貼於拍賣場內的**拍賣品**旁或 www.christies.com 的書面通知（上述通知內容會另行通知以電話或書面競投的客戶），或拍賣官舉行前或拍賣官**拍賣品**前拍賣官宣布的公告。

大寫字體：指包含所有的大寫字母。

保證：陳述人或聲明人保證其所陳述或聲明的事實為正確。

SYMBOLS USED IN THIS CATALOGUE

The meaning of words coloured in **bold** in this section can be found at the end of the section of the catalogue headed 'Conditions of Sale - Buying at Christie's'

○ Christie's has a direct financial interest in the **lot**. See Important Notices and Explanation of Cataloguing Practice.

△ Owned by Christie's or another **Christie's Group** company in whole or in part. See Important Notices and Explanation of Cataloguing Practice.

◆ Christie's has a direct financial interest in the **lot** and has funded all or part of our interest with the help of someone else. See Important Notices and Explanation of Cataloguing Practice.

· **Lot** offered without **reserve** which will be sold to the highest bidder regardless of the pre-sale estimate in the catalogue.

- **Lot** incorporates material from endangered species which could result in export restrictions. See Section H2(b) of the Conditions of Sale - Buying at Christie's.

Please note that **lots** are marked as a convenience to you and we shall not be liable for any errors in, or failure to, mark a **lot**.

本目錄中使用的各類標識

本部份粗體字體詞語的涵義載於本目錄中題為“業務規定·買方須知”一章的最後一頁。

○ 佳士得對該**拍賣品**擁有直接經濟利益。請參閱重要通知及目錄編列方法之說明。

△ 全部或部分由佳士得或其他**佳士得集團**公司持有。請參閱重要通知及目錄編列方法之說明。

◆ 佳士得對該**拍賣品**擁有直接經濟利益，佳士得的全部或部分利益通過第三方融資。請參閱重要通知及目錄編列方法之說明。

· 不設**底價**的**拍賣品**，不論其在本目錄中的售前**估價**，該**拍賣品**將售賣給出價最高的競投人。

- **拍賣品**含有瀕危物種的材料，可能受出口限制。請參閱業務規定·買方須知第 H2(b) 段。

請注意對藏品的標記僅為您提供方便，本公司不承擔任何因標示錯誤或遺漏標記的責任。

IMPORTANT NOTICES AND EXPLANATION OF CATALOGUING PRACTICE

IMPORTANT NOTICES

CHRISTIE'S INTEREST IN PROPERTY CONSIGNED FOR AUCTION

△: Property Owned in part or in full by Christie's

From time to time, Christie's may offer a lot which it owns in whole or in part. Such property is identified in the catalogue with the symbol △ next to its lot number.

○ Minimum Price Guarantees:

On occasion, Christie's has a direct financial interest in the outcome of the sale of certain lots consigned for sale. This will usually be where it has guaranteed to the Seller that whatever the outcome of the auction, the Seller will receive a minimum sale price for the work. This is known as a minimum price guarantee. Where Christie's holds such financial interest we identify such lots with the symbol ○ next to the lot number.

○◆ Third Party Guarantees/Irrevocable bids

Where Christie's has provided a Minimum Price Guarantee it is at risk of making a loss, which can be significant, if the lot fails to sell. Christie's therefore sometimes chooses to share that risk with a third party. In such cases the third party agrees prior to the auction to place an irrevocable written bid on the lot. The third party is therefore committed to bidding on the lot and, even if there are no other bids, buying the lot at the level of the written bid unless there are any higher bids. In doing so, the third party takes on all or part of the risk of the lot not being sold. If the lot is not sold, the third party may incur a loss. Lots which are subject to a third party guarantee arrangement are identified in the catalogue with the symbol ○◆.

The third party will be remunerated in exchange for accepting this risk based on a fee on the final hammer price in the event that the third party is not the successful bidder. The third party may also bid for the lot above the written bid and where it does so, and is the successful bidder, it will not receive a fee.

Third party guarantors are required by us to disclose to anyone they are advising their financial interest in any lots they are guaranteeing. However, for the avoidance of any doubt, if you are advised by or bidding through an agent on a lot identified as being subject to a third party guarantee you should always ask your agent to confirm whether or not he or she has a financial interest in relation to the lot.

Other Arrangements

Christie's may enter into other arrangements not involving bids. These include arrangements where Christie's has given the Seller an Advance on the proceeds of sale of the lot or where Christie's has shared the risk of a guarantee with a partner without the partner being required to place an irrevocable written bid or otherwise participating in the bidding on the lot. Because such arrangements are unrelated to the bidding process they are not marked with a symbol in the catalogue.

Bidding by parties with an interest

In any case where a party has a financial interest in a lot and intends to bid on it we will make a saleroom announcement to ensure that all bidders are aware of this. Such financial interests can include where beneficiaries of an Estate have reserved the right to bid on a lot consigned by the Estate or where a partner

in a risk-sharing arrangement has reserved the right to bid on a lot and/or notified us of their intention to bid.

Please see <http://www.christies.com/financial-interest/> for a more detailed explanation of minimum price guarantees and third party financing arrangements.

Where Christie's has an ownership or financial interest in every lot in the catalogue, Christie's will not designate each lot with a symbol, but will state its interest in the front of the catalogue.

FOR PICTURES, DRAWINGS, PRINTS AND MINIATURES, SCULPTURES, INSTALLATION, VIDEO, CALLIGRAPHY AND PAINTED CERAMIC

Terms used in this catalogue have the meanings ascribed to them below. Please note that all statements in this catalogue as to authorship are made subject to the provisions of the Conditions of Sale and authenticity warranty. Buyers are advised to inspect the property themselves. Written condition reports are usually available on request.

QUALIFIED HEADINGS

In Christie's opinion a work by the artist.

**Attributed to ...

In Christie's qualified opinion probably a work by the artist in whole or in part.

**Studio of .../ "Workshop of ..."

In Christie's qualified opinion a work executed in the studio or workshop of the artist, possibly under his supervision.

**Circle of ...

In Christie's qualified opinion a work of the period of the artist and showing his influence.

**Follower of ...

In Christie's qualified opinion a work executed in the artist's style but not necessarily by a pupil.

**Manner of ...

In Christie's qualified opinion a work executed in the artist's style but of a later date.

**After ...

In Christie's qualified opinion a copy (of any date) of a work of the artist.

**Signed ..."/"Dated ..."/

"Inscribed ..."

In Christie's qualified opinion the work has been signed/dated/inscribed by the artist.

**With signature ..."/"With date ..."/

"With inscription ..."

In Christie's qualified opinion the signature/ date/inscription appears to be by a hand other than that of the artist.

The date given for Old Master, Modern and Contemporary Prints is the date (or approximate date when prefixed with 'circa') on which the matrix was worked and not necessarily the date when the impression was printed or published.

*This term and its definition in this Explanation of Cataloguing Practice are a qualified statement as to authorship. While the use of this term is based upon careful study and represents the opinion of specialists, Christie's and the consignor assume no risk, liability and responsibility for the authenticity of authorship of any lot in this catalogue described by this term, and the Authenticity Warranty shall not be available with respect to lots described using this term.

OPTIONS TO BUY PARCELS

A parcel consists of several lots of the same wine of identical lot size, bottle size and description. Bidding will start on the first lot of the parcel and the successful buyer of that lot is entitled to take some or all of the remaining lots in the parcel at the same hammer price. If the buyer of the first lot does not take further lots, the remaining lots of the parcel will be offered in a similar fashion. We recommend that a bid on a parcel lot be placed on the first lot of the parcel. If the bid is superseded, Christie's will automatically move your bid to the next identical lot and so on. In all instances, such bids will be handled at the auctioneer's discretion.

CLASSIFICATIONS

Bordeaux Classifications in the text are for identification purposes only and are based on the official 1855 classification of the Médoc and other standard sources. All wines are Château-bottled unless stated otherwise.

ULLAGES AND CORKS OF OLD WINES

Wines are described in this catalogue as correctly as can be ascertained at time of going to press, but buyers of old wines must make appropriate allowances for natural variations of ullages, conditions of cases, labels, corks and wine. No returns will be accepted.

ULLAGE

The amount by which the level of wine is short of being full: these levels may vary according to age of the wines and, as far as can be ascertained by inspection prior to the sale, are described in the catalogue. A chart explaining level and ullage descriptions and interpretations, together with a visual presentation, appears in this catalogue. We hope you will find this helpful.

重要通知及目錄編列方法之說明

重要通告

佳士得在受委託拍賣品中的權益

△: 部分或全部歸佳士得擁有的拍賣品

佳士得可能會不時提供佳士得集團旗下公司全部或部分擁有之拍賣品。該等拍賣品在目錄中於拍賣編號旁註有 △ 符號以資識別。

◊: 保證最低出售價

佳士得有時就某些受委託出售的拍賣品的拍賣成持有直接的經濟利益。通常為其向賣方保證無論拍賣的結果如何，賣方將就拍賣品的出售獲得最低出售價。這被稱為保證最低出售價。該等拍賣品在目錄中於拍賣編號旁註有 ◊ 號以資識別。

◆: 第三方保證 / 不可撤銷的競投

在佳士得已經提供最低出售價保證，如果拍賣品未能出售，佳士得將承擔遭受重大損失的風險。因此，佳士得有時選擇與第三方分擔該風險。在這種情況下，第三方向意在拍賣之前該拍賣品提交一份不可撤銷的書面競投。第三方因此承諾競投該拍賣品，如果沒有其它競投，等三方將以書面競投價格購買該拍賣品，除非有其它更高的競投。第三方因此承擔拍賣品未能出售的所有或部分風險。如果拍賣品未能出售，第三方可能承擔損失。該等拍賣品在目錄中注以符號◆以資識別。

第三方需要承擔風險，在自身不是成功競投人的情況下，會收取基於成交價計算的酬金。第三方亦可以就該拍賣品以超過書面競投的價格進行競投。如果第三方成功競投，則不會收取任何酬金。

我們要求第三方保證人向其客戶披露在給予保證的拍賣品持有的經濟利益。如果您通過顧問意見或委託代理人競投一件標示為有第三方融資的拍賣品，我們建議您應當要求您的代理人確認她 / 他是否在拍賣品持有經濟利益。

其他安排

佳士得可能訂立與競投無關的協議。這些協議包括佳士得向賣方就拍賣品銷售所得預付金額或者佳士得與第三方分擔風險，但並不要求第三方提供不可撤銷的書面競投或參與拍賣品的競投。因為上述協議與競投過程無關，我們不會在目錄中注以符號。

利益方的競投

如果競投人在拍賣品持有經濟利益並欲競投該拍賣品，我們將以拍賣場通知的方式知會所有競投者。該經濟利益可包括遺產受益人保留權利參與競投，遺產委託拍賣的拍賣品或者風險共擔安排下的合作方保留權利參與競投拍賣品和 / 或通知我們其競投該拍賣品的意願。

請登錄 <http://www.christies.com/financial-interest/> 瞭解更多關於最低出售價保證以及第三方融資安排的說明。

如果佳士得在目錄中每一項拍賣品中均所有權或經濟利益，佳士得將不會於每一項拍賣品旁附註符號，但會於正文首頁聲明其權益。

有關繪畫、素描、版畫、小型畫、雕塑、裝置、錄像、書法及手繪瓷器

下列詞語於本目錄中具有以下意義。請注意本目錄中有關作者身份的所有聲明均按照本公司之業務規定及真品保證的條款而作出。

買方應親自檢視各拍賣品的狀況，亦可向佳士得要求提供書面狀況報告。

有保留的標題

佳士得認是屬於該藝術家之作品

* 「傳」、「認為是...之作品」

指以佳士得有保留之意見認為，某作品大概全部或部份是藝術家之創作。

* 「...之創作室」及「...之工作室」

指以佳士得有保留之意見認為，某作品在某藝術家之創作室或工作室完成，可能在他監督下完成。

* 「...時期」

指以佳士得有保留之意見認為，某作品屬於該藝術家時期之創作，並且反映出該藝術家之影響。

* 「銀隨...風格」

指以佳士得有保留之意見認為，某作品具有某藝術家之風格，但未必是該藝術家門生之作品。

* 「具有...創作手法」

指以佳士得有保留之意見認為，某作品具有某藝術家之風格，但於較後時期完成。

* 「...複製品」

指以佳士得有保留之意見認為，某作品是某藝術家作品之複製品（任何日期）。

* 「簽名...」、「日期...」、「題章...」

指以佳士得有保留之意見認為，某作品由某藝術家簽名 / 寫上日期 / 題詞。

* 「附有...簽名」、「附有...之日期」、「附有...之題詞」、「款」

指以佳士得有保留之意見認為某簽名 / 某日期 / 題詞不是某藝術家所為。

古代、近現代印刷品之日期是指製造作品之日期 [或大概日期] 而不一定是作品印刷或出版之日。

* 於本目錄編列方法之說明中此詞語及其定義為對作者身份而言之有規限說明。雖然本詞語之使用，乃基於審慎研究及代表專家之意見，佳士得及委託人於目錄內使用此詞語及其所描述之拍賣品及其作者身份之真確及可信性，並不承擔及接受任何風險、義務或責任，而真品保證條款，亦不適用於此詞語所描述之拍賣品。

購買一系列貨批的選擇權

一組貨批內含多批相同批量、瓶容量及種類的名酒。競投將會由一系列貨批之中的第一貨批開始，成功競投的買家將以相同的成交價購入系列中部分或全部貨批。若果第一貨批的買家未有進一步購入，該系列貨批的餘下貨批將會以相似的方式開放競投。佳士得建議對貨批的出價應在該系列貨批的第一貨批之上。如果出價被取代，佳士得將會自動把買家的出價置在下一相同貨批，如此類推。在所有情況下，有關出價均全權由拍賣官處理。

分類

內容中的波爾多分標標準僅作識別之用，並且根據 Médoc 1855 年正式的分類標準及其他標準來源。除註明外，所有名酒均在莊園內裝瓶。

舊酒的天然耗損及酒塞

在本目錄內列明的名酒均在印刷前確定內容正確，惟舊酒買家必須對自然程度的耗損、酒帽狀況、標簽、酒塞及各酒瓶的差異作出包容。恕不接受退貨。

耗損

名酒水位未能達至滿的水位之差距，有關差距會根據名酒之年期而有所不同，而在銷售前能通過檢驗確定的，均會在目錄中註明。本目錄以圖表的形式詳細說明水位與損耗量形容及解釋以方便閣下參考。

LEVEL/ULLAGE DESCRIPTIONS AND INTERPRETATIONS

(see notes below)

BORDEAUX

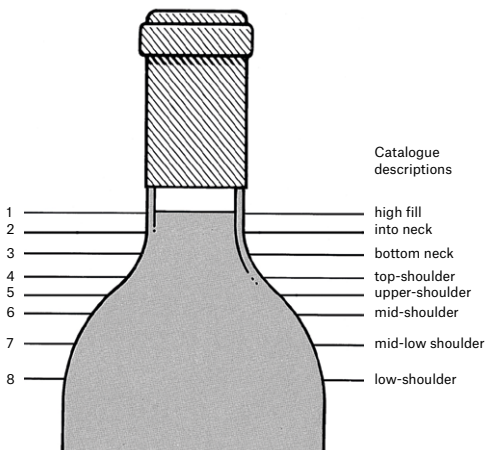

- 1 into neck: Level of young wines. Exceptionally good in wines over 10 years old.
- 2 bottom neck: Perfectly good for any age of wine. Outstandingly good for a wine of 20 years in bottle, or longer.
- 3 very top-shoulder
- 4 top-shoulder: Normal for any claret 15 years old or older.
- 5 upper-shoulder: Slight natural reduction through the easing of the cork and evaporation through cork and capsule. Usually no problem. Acceptable for any wine over 20 years old. Exceptional for pre-1950 wines.

BURGUNDY

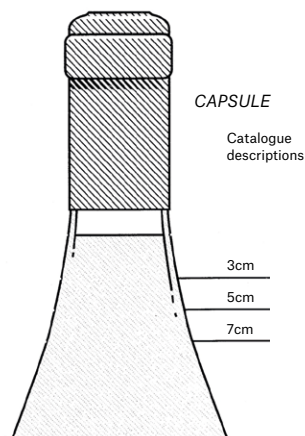

- 6 mid-shoulder: Probably some weakening of the cork and some risk. Not abnormal for wines 30/40 years of age. Estimates usually take this into account.
- 7 mid-low-shoulder: Some risk. Low estimates.
- 8 low-shoulder: Risky and usually only accepted for sale if wine or label exceptionally rare or interesting. Always offered with low estimate.

Because of the slope of shoulder it is impractical to describe levels as mid-shoulder, etc. Wherever appropriate the level between cork and wine will be measured and catalogued in centimetres.

The condition and drinkability of burgundy is less affected by ullage than its equivalent from Bordeaux. For example, a 5 to 7 cm. ullage in a 30-year-old burgundy can be considered normal, indeed good for age, 3.5 to 4 cm. excellent for age, even 7cm. rarely a risk.

BOTTLE SIZES

magnum	= two regular bottles	(1.5L)
marie-jeanne	= three regular bottles	(2.5L)
double-magnum	= four regular bottles	(3L)
jeroboam	= four regular bottles	(3L)
(Burgundy, Champagne)		
jeroboam	= six regular bottles	(5L)
(Bordeaux)		
(or 5 litres)		
impériale	= eight regular bottles	(6L)
(Bordeaux)		
methusalem	= eight regular bottles	(6L)
(Burgundy)		
balthazar	= sixteen regular bottles	(12L)
nebuchadnezzar	= twenty regular bottles	(15L)
melchior	= twenty-four regular bottles	(18L)

SPECIAL NOTICE

Though every effort is made to describe or measure the levels of older vintages, corks over 20 years old begin to lose their elasticity and levels can change between cataloguing and sale. Old corks have also been known to fail during or after shipment. **We therefore repeat that there is always a risk of cork failure with old wines and due allowance must be made for this. Under no circumstances can an adjustment of price or credit be made after delivery except under the terms stated in Paragraph I of the Conditions of Sale - Buying at Christie's. Unless otherwise stated, Bordeaux are château bottled and all wines are bottled in the country of production.**

Important note regarding opening of cases and listing of levels: Christie's general policy is to open all wood cases and to describe levels. Bidders must make allowances for reasonable variations in ullage which may be encountered in cases older than twenty years. Additionally, all wine younger than twenty years have levels bottom neck or better unless otherwise noted.

狀況 / 損耗量形容及解釋

(請細閱以下)

波爾多

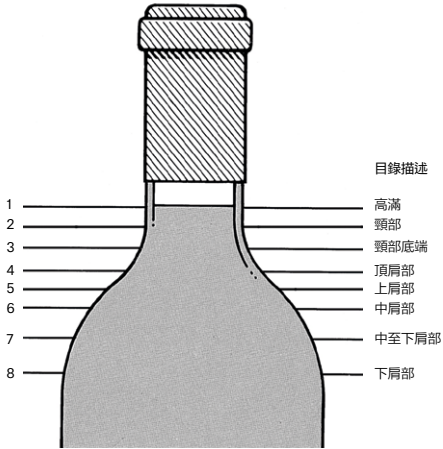

- 1 頸部：
新酒的正常水位。若酒齡超過 10 年的酒還保持這水位，是非常好的。
- 2 頸部底端：
對任何酒齡的酒來說，都是很好的，尤其是如酒齡是超過 20 年的酒。
- 3 最頂肩部
- 4 頂肩部：
正常的如酒齡是 15 年或以上。
- 5 上肩部：
因酒塞鬆懈及蒸發以至有少許自然的退減，一般是沒有問題的。可接受如酒齡超過 20 年。

目錄描述

- 高滿
- 頸部
- 頸部底端
- 頂肩部
- 上肩部
- 中肩部
- 中至下肩部
- 下肩部

- 6 中肩部：
酒塞可能有一些削弱，有一些風險，不是異常的如酒齡到達 30/40 年。估值通常會把此計算在內。
- 7 中至低肩部：
有些風險，低估值。
- 8 低肩部：
高風險及一般只會售賣當酒或招紙是很稀有或珍貴。常常也是低估值。

勃根地

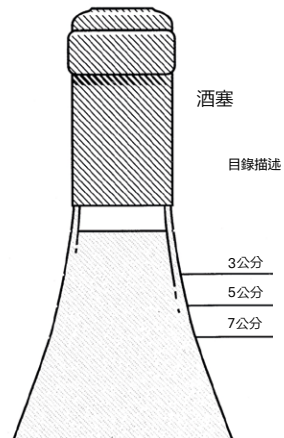

酒塞

目錄描述

- 3公分
- 5公分
- 7公分

由於肩部的斜度並不能夠形容中肩等的水位，在可能的情況下酒塞及名酒之間的距離將會以厘米量度及收錄。
勃根地酒的狀況及可飲用程度，較之於波爾多酒，較少受自然耗損影響。例如酒齡為三十年的勃根地酒有 5 至 7 厘米的自然耗損可視為正常。酒齡良好的，會有 3.5 至 4 厘米的自然耗損，酒齡超卓的甚至會有 7 厘米的自然耗損，很少具有風險。

酒瓶大小

magnum	= 2 個標準瓶 (1.5 公升)
marie-jeanne	= 3 個標準瓶 (2.5 公升)
double-magnum	= 4 個標準瓶 (3 公升)
jeroaboam (Burgundy, Champagne)	= 4 個標準瓶 (3 公升)
jeroaboam (Bordeaux)	= 6 個標準瓶 (5 公升) (或 5 升)
impériale (Bordeaux)	= 8 個標準瓶 (6 公升)
methuselah (Burgundy)	= 8 個標準瓶 (6 公升)
balthazar	= 16 個標準瓶 (12 公升)
nebuchadnezzar	= 20 個標準瓶 (15 公升)
melchior	= 24 個標準瓶 (18 公升)

特別通告

儘管已盡一切辦法去形容或量度較舊名酒的水位，超過 20 年的酒塞亦會開始失去其彈性，水位可能在收錄目錄及銷售期間改變。舊酒塞亦已知可能在運送或運抵後失效。佳士得因此重申舊酒的酒塞經常有損壞的風險，必須對此有適當的寬容。除出現在業務規定，買方須知第 1 段的情況，在任何情況下，在運送後均不可調整價格或退款。除註明外，所有波爾多酒均於莊園裝瓶，所有名酒均在生產國裝瓶。

有關打開酒箱及列明水位的重要註釋：佳士得一般的政策是打開所有木酒箱，並說明水位。按標者必須對酒齡 20 年及以上的名酒可能出現的自然耗損的合理差異有所寬容。此外，除另有註明，所有酒齡 20 年以下的名酒均有頸部底端或更佳的水位。

WORLDWIDE SALEROOMS AND OFFICES AND SERVICES

ARGENTINA
BUENOS AIRES
 +54 11 43 93 42 22
 Cristina Carlisle

AUSTRALIA
SYDNEY
 +61 (0)2 9326 1422
 Ronan Sulich

AUSTRIA
VIENNA
 +43 (0)1 533 881214
 Angela Bailou

BELGIUM
BRUSSELS
 +32 (0)2 512 88 30
 Roland de Lathuy

BERMUDA
BERMUDA
 +1 401 849 9222
 Betsy Ray

BRAZIL
RIO DE JANEIRO
 +5521 2225 6553
 Candida Sodre

SÃO PAULO
 +5511 3061 2576
 Nathalie Lenci

CANADA
TORONTO
 +1 416 960 2063
 Brett Sherlock

CHILE
SANTIAGO
 +56 2 2 2631642
 Denise Ratnoff
 de Lira

COLOMBIA
BOGOTA
 +571 635 54 00
 Juanita Madrinan

DENMARK
COPENHAGEN
 +45 3962 2377
 Birgitte Hillingsø
 (Consultant)
 + 45 2612 0092
 Rikke Juel Brandt
 (Consultant)

**FINLAND AND
 THE BALTIC STATES**
HELSINKI
 +358 40 5837945
 Barbro Schauman
 (Consultant)

FRANCE
**BRITTANY AND
 THE LOIRE VALLEY**
 +33 (0)6 09 44 90 78
 Virginie Gregory
 (Consultant)

**GREATER
 EASTERN FRANCE**
 +33 (0)6 07 16 34 25
 Jean-Louis Janin Daviet
 (Consultant)

NORD-PAS DE CALAIS
 +33 (0)6 09 63 21 02
 Jean-Louis Brémilts
 (Consultant)

-PARIS
 +33 (0)1 40 76 85 85

**POITOU-CHARENTE
 AQUITAINE**
 +33 (0)5 56 81 65 47
 Marie-Cécile Moueix

**PROVENCE -
 ALPES CÔTE D'AZUR**
 +33 (0)6 71 99 97 67
 Fabienne Albertini-Cohen

RHÔNE ALPES
 +33 (0)6 61 81 82 53
 Dominique Pierron
 (Consultant)

GERMANY
DÜSSELDORF
 +49 (0)21 14 91 59 352
 Arno Verkade

FRANKFURT
 +49 (0)173 317 3975
 Anja Schaller (Consultant)

HAMBURG
 +49 (0)40 27 94 073
 Christiane Grafm
 zu Rantzau

MUNICH
 +49 (0)89 24 20 96 80
 Marie Christine Gräfin
 Huyn

STUTTGART
 +49 (0)71 12 26 96 99
 Eva Susanne
 Schweizer

INDIA
-MUMBAI
 +91 (22) 2280 7905
 Sonal Singh

DELHI
 +91 (011) 6609 1170
 Sanjay Sharma

INDONESIA
JAKARTA
 +62 (0)21 7278 6268
 Charmie Hamami

ISRAEL
TEL AVIV
 +972 (0)3 695 0695
 Roni Glat-Baharaff

ITALY
-MILAN
 +39 02 303 2831

ROME
 +39 06 686 3333
 Marina Cicogna

NORTH ITALY
 +39 348 3131 021
 Paola Gradi
 (Consultant)

TURIN
 +39 347 2211 541
 Chiara Massimello
 (Consultant)

VENICE
 +39 041 277 0086
 Bianca Arrivabene Valenti
 Gonzaga (Consultant)

BOLOGNA
 +39 051 265 154
 Benedetta Possati Vittorio
 Venenti (Consultant)

GENOA
 +39 010 245 3747
 Rachele Guicciardi
 (Consultant)

FLORENCE
 +39 055 219 012
 Alessandra Niccolini di
 Camugliano (Consultant)

**CENTRAL &
 SOUTHERN ITALY**
 +39 348 520 2974
 Alessandra Allaria
 (Consultant)

JAPAN
TOKYO
 +81 (0)3 6267 1766
 Chie Banta

MALAYSIA
KUALA LUMPUR
 +60 3 6207 9230
 Lim Meng Hong

MEXICO
MEXICO CITY
 +52 55 5281 5546
 Gabriela Lobo

MONACO
 +377 97 97 11 00
 Nancy Dotta

THE NETHERLANDS
-AMSTERDAM
 +31 (0)20 57 55 255

NORWAY
OSLO
 +47 975 800 78
 Katinka Traaseth
 (Consultant)

**PEOPLES REPUBLIC
 OF CHINA**
BEIJING
 +86 (0)10 8583 1766

-HONG KONG
 +852 2760 1766

-SHANGHAI
 +86 (0)21 6355 1766

PORTUGAL
LISBON
 +351 919 317 233
 Mafalda Pereira Coutinho
 (Consultant)

RUSSIA
MOSCOW
 +7 495 937 6364
 +44 20 7389 2318
 Katya Vinokurova

SINGAPORE
SINGAPORE
 +65 6735 1766
 Nicole Tee

SOUTH AFRICA
CAPE TOWN
 +27 (21) 761 2676
 Juliet Lomborg
 (Independent Consultant)

**DURBAN &
 JOHANNESBURG**
 +27 (31) 207 8247
 Gillian Scott-Berning
 (Independent Consultant)

WESTERN CAPE
 +27 (44) 533 5178
 Annabelle Conyngham
 (Independent Consultant)

SOUTH KOREA
SEOUL
 +82 2 720 5266
 Hye-Kyung Bae

SPAIN
BARCELONA
 +34 (0)93 487 8259
 Carmen Schjaer

MADRID
 +34 (0)91 532 6626
 Juan Varez
 Dalia Padilla

SWEDEN
STOCKHOLM
 +46 (0)73 645 2891
 Claire Ahman (Consultant)
 +46 (0)70 9369 201
 Louise Dyhlen
 (Consultant)

SWITZERLAND
-GENEVA
 +41 (0)22 319 1766
 Eveline de Proyart

-ZURICH
 +41 (0)44 268 1010
 Dr. Bertold Mueller

TAIWAN
TAIPEI
 +886 2 2736 3356
 Ada Ong

THAILAND
BANGKOK
 +66 (0)2 652 1097
 Satima Tanabe

TURKEY
ISTANBUL
 +90 (832) 558 7514
 Eda Kehale Argün
 (Consultant)

**UNITED ARAB
 EMIRATES**
-DUBAI
 +971 (0) 4 425 5647

UNITED KINGDOM
**- LONDON,
 KING STREET**
 +44 (0)20 7839 9060

**- LONDON,
 SOUTH KENSINGTON**
 +44 (0)20 7930 6074

**NORTH AND
 NORTHEAST
 LISBON**
 +44 (0)20 3219 6010
 Thomas Scott

**NORTHWEST
 AND WALES**
 +44 (0)20 7752 3033
 Jane Blood

SOUTH
 +44 (0)1730 814 300
 Mark Wrey

SCOTLAND
 +44 (0)131 225 4756
 Bernard Williams
 Robert Lagneau
 David Bowes-Lyon
 (Consultant)

ISLE OF MAN
 +44 (0)20 7389 2032

CHANNEL ISLANDS
 +44 (0)20 7389 2032

IRELAND
 +353 (0)87 638 0996
 Christine Ryall
 (Consultant)

UNITED STATES
CHICAGO
 +1 312 787 2765
 Lisa Cavanaugh

DALLAS
 +1 214 599 0735
 Capera Ryan

HOUSTON
 +1 713 802 0191
 Jessica Phifer

LOS ANGELES
 +1 310 385 2600

MIAMI
 +1 305 445 1487
 Jessica Katz

NEWPORT
 +1 401 849 9222
 Betsy D. Ray

-NEW YORK
 +1 212 636 2000

SAN FRANCISCO
 +1 415 982 0982
 Eilanor Notides

AUCTION AND OTHER SERVICES

PRIVATE SALES
 HK: +852 2978 6871
 Fax: +852 2760 1767
 Email: privatesalesservicecentre@christies.com

CHRISTIE'S EDUCATION

New York
 Tel: +1 212 355 1501
 Fax: +1 212 355 7370
 Email: newyork@christies.edu

Hong Kong
 Tel: +852 2978 6768
 Fax: +852 2525 3856
 Email: hongkong@christies.edu

London
 Tel: +44 (0)20 7665 4350
 Fax: +44 (0)20 7665 4351
 Email: london@christies.edu

CHRISTIE'S INTERNATIONAL REAL ESTATE

New York
 Tel: +1 212 468 7182
 Fax: +1 212 468 7141
 Email: info@christiesrealestate.com

London
 Tel: +44 (0)20 7389 2551
 Fax: +44 (0)20 7389 2168
 Email: info@christiesrealestate.com

Hong Kong
 Tel: +852 2978 6788
 Fax: +852 2845 2646
 Email: info@christiesrealestate.com

CHRISTIE'S FINE ART STORAGE SERVICES

New York
 Tel: +1 212 974 4579
 Email: newyork@cfass.com

Singapore
 Tel: +65 6543 5252
 Email: singapore@cfass.com

• DENOTES SALEROOM

ENQUIRIES – Call the Saleroom or Office
 For a complete salerooms & offices listing go to christies.com

EMAIL – info@christies.com

CHRISTIE'S HONG KONG WINE COLLECTION AND STORAGE

All wines offered for auction in this catalogue are lying in Christie's appointed cellar, Crown Wine Cellars.

Buyers wishing to collect from the storage facility directly may do so by prior arrangement. Crown Wine Cellars will only release the lots upon your signature of a Christie's Collection Order. Request for deliveries can be made after receipt of cleared funds and must be at least 2 business days prior to date of delivery. All shipping charges, local delivery charges, transit insurance and packing will be at the expense of the buyers. All charges will have to be prepaid to Christie's before shipment can be effected. All breakages or missing bottles must be reported to Christie's within three days of collection or delivery of the wine lots. To arrange the pick-up or delivery of your purchase, please contact Mr. Kelvin Pun of Crown Wine Cellars at +852 2453 3530.

If lots are not collected within thirty-five calendar days following the sale, Crown Wine Cellars Limited will charge you and you will have to pay all storage charges incurred from the thirty-sixth calendar day following the sale for the period while the lot(s) are stored at Crown Wine Cellars Limited's storage facility. Crown Wine Cellars Limited will invoice the buyers directly. Buyers agree that Christie's will provide the buyers' contact details to Crown Wine Cellars Limited for the purposes of invoicing and collection of storage fees.

Local Delivery Charges for normal orders (All prices are subject to change)

Urgent, express orders and other areas not mentioned below will be quoted separately.

Delivery/Collection			
Bottle	Hong Kong Island	Kowloon & New Territories	Lantau Island & Ma Wan
1-6	HKD300	HKD210	HKD330
7-12	HKD350	HKD260	HKD380
13-48	HKD450	HKD360	HKD480
49-240	HKD620	HKD530	HKD650

* For 241 bottles and above, please contact Crown Wine Cellars at Tel: +852 2453 3530.

** Delivery Charges include insurance.

Delivery Schedule: Monday to Friday 11:00-17:00
Saturday before 12:00

The storage facility information is listed below:

Storage Facility (Tuen Mun)

Contact: Mr. Kelvin Pun/Ms. Angel Lam
Email: kpun@crownew.com
Tel: +852 2453 3530
Address: 2/F, Crown Data Centre 1,
6 Kin Fung Circuit, Tuen Mun, N.T.

Office Hours: Monday to Friday 10:00-12:30 and 14:00-17:30
Saturday 10:00-12:30

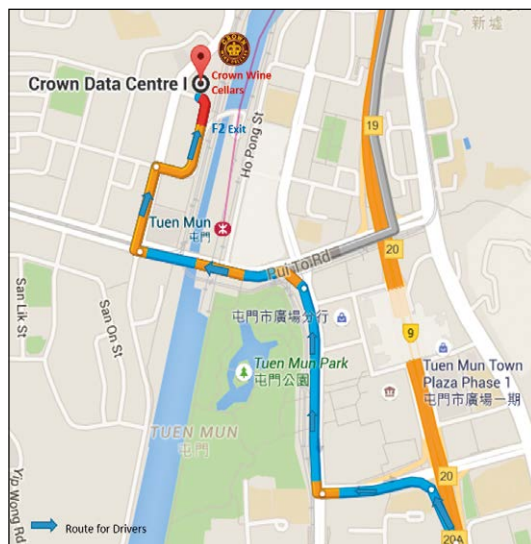

Overseas Delivery

For designated countries, Christie's will be pleased to assist with making arrangements for the packing, shipping and transit insurance of the purchased lots at the buyer's request and expense upon receipt of all outstanding payment in cleared funds. Christie's will obtain quotes at the buyer's request. All shipping charges have to be agreed and pre-paid before shipment can be effected. Christie's charges a 10% administrative fee on the shipping quote for managing your shipment. Please be reminded that all shipping quotes are exclusive of any tax and/or duties imposed by government authorities. It is the Buyer's sole responsibility to obtain any required export or import licenses.

Please contact our Post-Sale Services Department +852 2760 1766 or postsalesia@christies.com for further information.

香港佳士得名酒提取及儲存

所有在此拍賣的名酒現儲存於佳士得委任的酒窖 - Crown Wine Cellars Limited。

買家如欲直接從儲存設施提貨，請作提前通知以作安排。買家需要簽署由佳士得發出的提貨通知單，以便 Crown Wine Cellars Limited 發放拍賣品。買家支付所有費用後可提出貨品付運的要求，但有關要求必需於付運日期前的兩個工作天提出。買家須負責提取或安排本地送遞及/或運送。所有運費、本地送遞、運輸保險及包裝的費用將由買家負責。所有費用要在運送前預先繳付予佳士得，才會進行付運。所有破損或遺漏瓶數，必須在收到拍賣品後的三天內向佳士得報告。有關安排運送及提取事宜，請聯絡 Crown Wine Cellars Limited 潘先生，電話為 +852 2453 3530。

如果已購買的名酒在拍賣日後三十五個日曆天內仍未提取，即表示授權 Crown Wine Cellars Limited 儲存該名酒，有關儲存費用會由買家支付，直至該名酒被提取為止。Crown Wine Cellars Limited 將會向買家收取儲存費用並直接向買家發出發票。買家同意佳士得向 Crown Wine Cellars Limited 提供買家之資料，作為發出發票和收取儲存費之用途。

本地普通運單付運費用（價格或有更改）

加急運單及其他不在運輸範圍內區域的運單，請向佳士得名酒部查詢。

送貨 / 收貨			
數量	香港島	九龍及新界	大嶼山及馬灣
1-6 瓶	港幣 300	港幣 210	港幣 330
7-12 瓶	港幣 350	港幣 260	港幣 380
13-48 瓶	港幣 450	港幣 360	港幣 480
49-240 瓶	港幣 620	港幣 530	港幣 650

* 241 瓶及以上，請向 Crown Wine Cellars 查詢 +852 2453 3530。

** 送貨收費包括保險費。

送貨時間：星期一至五 上午十一時至下午五時
星期六 正午十二時前

有關儲存設施資料列舉如下：

儲存設施（屯門）

聯絡人：潘先生 / 林小姐
電郵：kpun@crownwww.com
辦公室電話：+852 2453 3530
地址：新界屯門建豐街 6 號
嘉柏中心 1 期 2 樓

酒窖辦公時間：星期一至五 上午十時正至下午十二時三十分及
下午二時正至下午五時三十分
星期六 上午十時正至下午十二時三十分

海外付運

若付運到其他指定國家，在買方以清算現金全數付清所有欠款後，佳士得可依照買家之要求，代為安排包裝、付運及運輸保險事宜，買家須繳付有關收費。佳士得會根據買家要求，提供報價給予買家。所有付運須於買家同意該運費及繳付後方作安排。佳士得會收取付運報價的 10% 以作行政費用。請注意所有付運報價不包括任何稅項及 / 或出入口稅項。買家須負責取得所有相關的進出口牌照。

詳情請向香港佳士得售後服務部 +852 2760 1766 或 postsaleasia@christies.com 查詢。

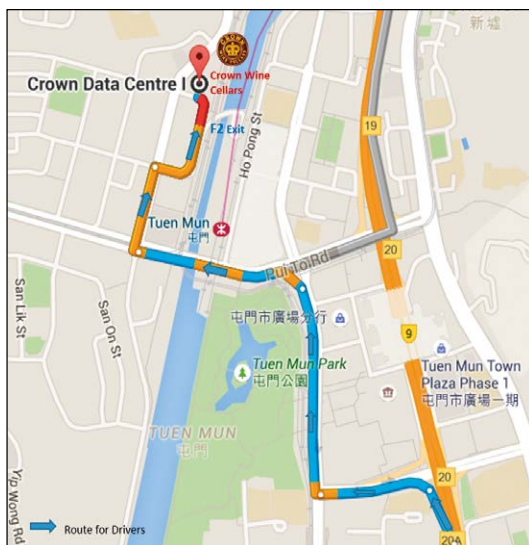

FINE AND RARE WINES:

A GENTLEMAN'S COLLECTION

FRIDAY 25 NOVEMBER 2016

AT 5.30 PM (LOTS 5001-5233) &

SATURDAY 26 NOVEMBER 2016

AT 10.30 AM (LOTS 5234-5463)

Grand Hall,
Hong Kong Convention and Exhibition Centre,
No.1 Expo Drive, Wanchai, Hong Kong

CODE NAME: GENTLEMAN

SALE NUMBER: 12576

LOT NUMBER: 5001-5463

Please note that Christie's does not accept payment from third parties, including agents, and that invoice details cannot be changed after the sale.

BID ONLINE FOR THIS SALE AT
WWW.CHRIStIES.COM

BIDDING INCREMENTS

Bidding generally starts below the **low estimate** and increases in steps (bid increments) of up to 10 per cent. The auctioneer will decide where the bidding should start and the bid increments. Written bids that do not conform to the increments set below may be lowered to the next bidding interval.

HK\$1,000 to HK\$2,000	by HK\$100s
HK\$2,000 to HK\$3,000	by HK\$200s
HK\$3,000 to HK\$5,000	by HK\$200, 500, 800 (ie: HK\$4,200, HK\$4,500, HK\$4,800)
HK\$5,000 to HK\$10,000	by HK\$500s
HK\$10,000 to HK\$20,000	by HK\$1,000s
HK\$20,000 to HK\$30,000	by HK\$2,000s
HK\$30,000 to HK\$50,000	by HK\$2,000, 5,000, 8,000 (ie: HK\$32,000, HK\$35,000, HK\$38,000)
HK\$50,000 to HK\$100,000	by HK\$5,000s
HK\$100,000 to HK\$200,000	by HK\$10,000s
HK\$200,000 to HK\$300,000	by HK\$20,000s
HK\$300,000 to HK\$500,000	by HK\$20,000, 50,000, 80,000 (ie: HK\$320,000, HK\$350,000, HK\$380,000)
HK\$500,000 to HK\$1,000,000	by HK\$50,000s
Above HK\$1,000,000	at auctioneer's discretion

The auctioneer may vary the increments during the course of the auction at his or her own discretion.

- I request Christie's to bid on the stated **lots** up to the maximum bid I have indicated for each **lot**.
- I understand that if my bid is successful the amount payable will be the sum of the **hammer price** and the **buyer's premium (together with any taxes chargeable on the hammer price and buyer's premium in accordance with the Conditions of Sale - Buying at Christie's)**. The **buyer's premium** rate shall be an amount equal to 25% of the **hammer price** of each **lot** up to and including HK\$ 1,200,000, 20% on any amount over HK\$ 1,200,000 up to and including HK\$ 20,000,000 and 12% of the amount above HK\$ 20,000,000. For wine there is a flat rate of 22.5% of the **hammer price** of each **lot** sold.
- I agree to be bound by the Conditions of Sale - Buying at Christie's printed in the catalogue.
- I understand that if Christie's receive written bids on a **lot** for identical amounts and at the auction these are the highest bids on the lot, Christie's will sell the **lot** to the bidder whose written bid it received and accepted **first**.
- Written bids submitted on **'no reserve'** **lots** will, in the absence of a higher bid, be executed at approximately 50% of the **low estimate** or at the amount of the bid if it is less than 50% of the **low estimate**.

I understand that Christie's written bid service is a free service provided for clients and that, while Christie's will be as careful as it reasonably can be, Christie's will not be liable for any problems with this service or loss or damage arising from circumstances beyond Christie's reasonable control.

Auction Results: +852 2760 1766

The auctioneer will usually only accept bids for High Value Lots if a deposit has been arranged prior to the day of sale and the High Value Lot pre-registration application has been completed. High Value Lot Deposit Forms should be sent to the Bids Department by email to bidsasia@christies.com. I understand that if I have not completed the High Value Lot pre-registration before sale I will not be permitted to bid for High Value Lots.

If you are not successful in any bid and do not owe any Christie's group company any money, the deposit will be refunded to you by way of wire transfer or such other method as determined by Christie's. Please make sure that you provide your bank details in the High Value Lot Deposit Forms.

Written Bids Form

Christie's Hong Kong

Written bids must be received at least 24 hours before the auction begins. Christie's will confirm all bids received by e-mail by return e-mail. If you have not received confirmation within one business day, please resubmit your bid(s) or contact: Bid Department.
Tel: +852 2978 9910 Email: bidsasia@christies.com.

Client Number (if applicable)

Client Name (please print)

Address

Post Code

Contact Number (Mobile)

(Fax)

Email

Please tick if you do not want to receive your invoice by email.

Please tick if you prefer not to receive information about our upcoming sales by e-mail

I HAVE READ AND UNDERSTOOD THIS WRITTEN BID FORM AND THE CONDITIONS OF SALE - BUYING AT CHRISTIE'S

Signature

Date

If you have not previously bid or consigned with Christie's, please attach copies of the following documents. **Individuals:** government-issued photo identification (such as a photo driving licence, national identity card, or passport) and, if not shown on the ID document, proof of current address, for example a utility bill or bank statement. **Corporate clients:** certificate of incorporation, proof of company address, photo ID copy of the authorized bidder, letter of authorization duly signed by the director or the legal representative and, where applicable, chopped with company stamp and official document listing directors and shareholders. **Other business structures such as trusts, offshore companies or partnerships:** please contact the Credit Department at + 852 2978 6870 for advice on the information you should supply. If you are registering to bid on behalf of someone who has not previously bid or consigned with Christie's, please attach identification documents for yourself as well as the party on whose behalf you are bidding, together with a signed letter of authorisation from that party.

New clients, clients who have not made a purchase from any Christie's office within the last 12 months, and those wishing to spend more than on previous occasions will be asked to supply a bank reference and/or a recent bank statement and we may also require a deposit as we deem appropriate as a condition of allowing you to bid. If you are asked to provide a deposit, you will need to arrange payment with us. Your bidder registration will not be considered complete until we receive payment of the deposit in full and cleared funds.

PLEASE PRINT CLEARLY

Lot number (in numerical order)	Number of Lots required	Maximum Bid HK\$ (excluding buyer's premium)



CHRISTIE'S 佳士得

佳士得名釀

二〇一六年 十一月二十五日
星期五 下午五時正
(拍賣品編號 5001-5233) 及
二〇一六年 十一月二十六日
星期六 上午十時三十分
(拍賣品編號 5234-5463)

香港灣仔博覽道1號
香港會議展覽中心大會堂

編號名稱: **GENTLEMAN**
拍賣編號: **12576**
拍賣品編號: **5001-5463**

佳士得不接受包括代理人在內的第三方付款；付款資料於拍賣會完結後將不能更改。

參與網絡競投可登入佳士得網站 www.christies.com

競投價遞增幅度

競投一般由低於**低價估價**開始，通常每次減價之遞增幅度（競投價遞增幅度）最高為10%，拍賣官會自行決定競投開始價位及遞增幅度。書面競投價若與下列之遞增幅度不一致，將被調低至下一個減價金額：

競投價	每次減價之遞增金額
1,000-2,000 港元	100 港元
2,000-3,000 港元	200 港元
3,000-5,000 港元	200, 500, 800 港元 (例 4,200, 4,500, 4,800 港元)
5,000-10,000 港元	500 港元
10,000-20,000 港元	1,000 港元
20,000-30,000 港元	2,000 港元
30,000-50,000 港元	2,000, 5,000, 8,000 港元 (例 32,000, 35,000, 38,000 港元)
50,000-100,000 港元	5,000 港元
100,000-200,000 港元	10,000 港元
200,000-300,000 港元	20,000 港元
300,000-500,000 港元	20,000, 50,000, 80,000 港元 (例 320,000, 350,000, 380,000 港元)
500,000-1,000,000 港元	50,000 港元
1,000,000 港元或以上	拍賣官自行決定

在拍賣時拍賣官可酌情更改每次增加之額度。

1. 茲請求佳士得就本表格所列的**拍賣品**進行競投，直至本表格所列的最高出價。
2. 本人知悉如競投成功，本人應付之購買款項為**成交價及買方酬金（以及所有基於成交價和買方酬金而產生的稅費，及符合業務規定，買方須知）**。買方酬金費率按每件**拍賣品**成交價首港幣1,200,000元之25%，加逾港幣1,200,000元以上至20,000,000元部份之20%；加逾港幣20,000,000元以上之12%計算。名釀的**買方酬金**是按每件**拍賣品**成交價之22.5%。
3. 本人同意接受本目錄中所列之業務規定的管轄。
4. 本人理解如佳士得收到多個競投價相等的書面競投，而在拍賣時此等競投價乃該**拍賣品**之最高出價，則該**拍賣品**售給最先送達其書面競投書給本公司之競投人。
5. 如果您以書面競投一件**沒有應價**的**拍賣品**，而且沒有其他更高叫價，我們會為您以**低價估價**的50%進行競投；或如果您的投標價低於**低價估價**的50%，則以您的投標價進行競投。

本人亦明白，佳士得的書面競投服務為一項向客戶提供的免費服務，佳士得會合理謹慎進行，佳士得不曾就任何在佳士得控制的範圍以外產生的損失或賠償負責。

拍賣結果查詢：+852 2760 1766

拍賣官一般僅接受已於拍賣日前繳付保證金並已完成高價拍賣品預先登記人士之高價拍賣品競投。請將已填妥之高價拍賣品之登記表格電郵 bridsasia@christies.com 至投標部。本人知悉若本人未於拍賣前完成高價拍賣預先登記，本人將不獲准競投高價拍賣品。

若閣下未能成功競投任何**拍賣品**，對佳士得或**佳士得集團**其他公司亦無任何欠款，保證金將以電匯方式或佳士得決定之其他方式退還閣下。請確保閣下已提供有關之銀行資料詳情。

書面競投表格

香港佳士得

書面競投必須在拍賣開始前至少 24 小時收到。

佳士得公司將以電郵確認收到閣下電郵之書面競投表格。如您在一個工作日內未能收到確認，請重新遞交書面競投表格或聯繫投標部。

電話：+852 2978 9910 電郵：bridsasia@christies.com

客戶編號（若適用）

客戶名稱（請用正楷填寫）

地址

郵編

聯絡電話（手提電話）

傳真

電郵

如閣下選擇不以電郵方式收取發票，請於方格內劃上「✓」號。

如閣下不希望透過電郵接收本公司將舉行的拍賣、活動或其他由佳士得集團及其聯營公司提供的服務資料，請於方格內劃上「✓」號。

我本人已細閱並理解本書面競投表格及業務規定。買方須知。

簽名

日期

如閣下未曾於佳士得競投或託售**拍賣品**，請附上以下文件之副本。個人：政府發出附有相片的身分證明文件（如國民身分證或護照），及（如身分證明文件未有顯示現時住址）現時住址證明，如公用事業帳單或銀行月結單。公司客戶：公司註冊證書、公司地址證明、被授權競投者附有相片的身分證明文件，由公司董事或法人按公司規定簽署及（若有）蓋有公司章的競投授權書，以及列出所有董事及股東的公司文件。其他業務結構，如**信託機構、離岸公司或合夥公司**：請與信用部聯絡，以諮詢閣下須提供何種資料，電話為+852 2978 6870。如閣下登記代表未曾於佳士得競投或託售**拍賣品**人士競投，請附上閣下本人的身分證明文件，以及閣下所代表競投人士的身分證明文件，連同該人士簽署的授權書。

新客戶、過去十二個月內未有在佳士得投得**拍賣品**，及本次擬出價金額高於過往之客戶，須提供銀行信用證明及/或近期的銀行月結單，亦或須繳付本公司指定的有關保證金作為允許閣下競投的先決條件。如閣下被要求提供保證金，閣下需與我們聯繫以安排付款。閣下的競投申請會在我們收到保證金的全額付款後方可作實。

請用正楷填寫清楚

拍賣品編號 (按數字排序)	拍賣品數量	最高競投價（港幣） (買方酬金不計在內)



BIDDER REGISTRATION FORM

Paddle No.

We encourage new clients to register at least 48 hours in advance of a sale to allow sufficient time to process the registration.

Please complete and sign this form and send it to us by email registrationasia@christies.com.

A Bidder's Detail

Personal Account: Account Holder Authorised Agent (Name)

Authorisation Letter and ID (if applicable): Attached In System/previously provided

Company Account: I am (name and position)

Authorisation Letter and ID (if applicable): Attached In System/previously provided

Account No.

Account Name

Business Registration No.

Invoice Address Room/Flat Floor Block

Building/Estate

Street Address

City/District Post/Zip Code

County/Province/State Country

The name and address given above will appear on the invoice for lots purchased with your assigned paddle for this registration. Please check that the details are correct as the invoice cannot be changed after the sale.

Country Code Phone No. Email

B Identity Documents and Financial References

If you have not previously bid or consigned with Christie's, please provide copies of the following documents. **Individuals:** government-issued photo identification (such as a national identity card or passport) and, if not shown on the ID document, proof of current address, for example a utility bill or bank statement. **Corporate clients:** a certificate of incorporation, proof of company address, photo ID copy of the authorized bidder, letter of authorization duly signed by the director or the legal representative and, where applicable, chopped with company stamp and official document listing directors and shareholders. **Other business structures such as trusts, offshore companies or partnerships:** please contact the Credit Department at +852 2978 6870 for advice on the information you should supply. If you are registering to bid on behalf of someone who has not previously bid or consigned with Christie's, please attach identification documents for yourself as well as the person on whose behalf you are bidding, together with a signed letter of authorisation from the person. New clients, clients who have not made a purchase from any Christie's office within the last 12 months, and those wishing to spend more than on previous occasions will be asked to supply a bank reference and/or a recent bank statement and we may also require a deposit as we deem appropriate as a condition of allowing you to bid. If you are asked to provide a deposit, you will need to arrange payment with us. Your bidder registration will not be considered complete until we receive payment of the deposit in full and cleared funds.

High Value Lots Paddle Registration:

Do you require a High Value Lot ("HVL") paddle? Yes No

You will need a HVL paddle if you intend to bid on: (i) any lot in the Asian 20th Century & Contemporary Art Evening Sale; The Pioneers or (ii) a lot the low estimate of which is HK\$ 8 million or above. The auctioneer will only take bids on High Value Lots from bidders holding HVL paddles. To secure your HVL paddle, you will need to pay a HVL deposit, which we will calculate for you. Generally it will be the higher of: (i) HK\$ 1 million or (ii) 20% of the aggregate low estimates of the HVLs you intend to bid on; or (iii) such other amount as we may determine from time to time. You can pay your HVL deposit using any of the following methods: credit card(s) acceptable to Christie's; wire transfer; cashier order or cheque. We cannot accept payment from third parties and agents. The HVL registration procedure applies even if you have already registered to bid in our sales on other lots. Please allow at least 48 hours for processing of your HVL registration. We reserve the right to change our HVL registration procedure and requirements from time to time without notice.

Please indicate the bidding level you require:

- HK \$ 0 - 500,000 HK \$ 500,001 - 2,000,000 HK \$ 2,000,001 - 4,000,000
- HK \$ 4,000,001 - 8,000,000 HK \$ 8,000,001 - 20,000,000 HK \$ 20,000,000 +

C Sale Registration

Please register me for the following sessions:

- | | |
|--|---|
| <input type="checkbox"/> 12576 Fine and Rare Wines: A Gentleman's Collection | <input type="checkbox"/> 12578 Important Watches |
| <input type="checkbox"/> 12577 Fine and Rare Wines Featuring Exceptional Private Collections | <input type="checkbox"/> 12561 Fine Chinese Classical Paintings and Calligraphy |
| <input type="checkbox"/> 14617 The Pioneers | <input type="checkbox"/> 12562 Fine Chinese Modern Paintings |
| <input type="checkbox"/> 12520 Asian 20th Century & Contemporary Art (Evening Sale) | <input type="checkbox"/> 12579 Hong Kong Magnificent Jewels |
| <input type="checkbox"/> 12521 Asian Contemporary Art (Day Sale) | <input type="checkbox"/> 12675 Chinese Ceramics From The Yangdetang Collection |
| <input type="checkbox"/> 12523 Asian 20th Century Art (Day Sale) | <input type="checkbox"/> 12587 Handbags & Accessories |
| <input type="checkbox"/> 12560 Chinese Contemporary Ink | <input type="checkbox"/> 12563 Important Chinese Ceramics and Works of Art |

D Collection and Shipment

Please select one of the following options:

- I will collect my purchased lot(s).
- Please provide a shipping quotation to my account address/the below address:
-
-

E Declarations

- I have read the "Conditions of Sale - Buying at Christie's" and "Important Notices and Explanation of Cataloguing Practice" printed in the sale catalogue, as well as the "No Third Party Payment Notice" and agree to be bound by them.
 - I have read the data collection section of the conditions of sale printed in the sale catalogue and agree to be bound by its terms.
 - The auctioneer will usually only accept bids for high value lots if a deposit has been arranged before the day of the auction and the high value lot pre-registration application has been completed. I understand that if I have not completed the high value lot pre-registration before the auction I will not be permitted to bid for high value lots.
 - If you are not successful in any bid and do not owe any Christie's group company any money, the deposit will be refunded to you by way of wire transfer or such other method as determined by Christie's. please make sure that you provide your bank details to us.
- Please tick if you are a new client and would like to receive information about sales, events and other services offered by the Christie's group and its affiliates by e-mail. You can opt-out of receiving this information at any time.
- Invoice will be sent by email. Please tick if you do NOT wish to receive your invoice by email.

Name Signature Date

Christie's Hong Kong Limited

22nd Floor Alexandra House, 18 Chater Road, Central, Hong Kong Tel: +852 2760 1766
www.christies.com

投標者登記表格

競投牌編號

建議新客戶於拍賣舉行前至少 48 小時辦理登記，以便有充足時間處理登記手續。

請填妥並簽署本表格然後電郵至 registrationasia@christies.com。

A 投標者資料

個人名義競投： 本人 代理人 (姓名)

授權書及身份證明文件 (如適用)： 現附上 在佳士得記錄上 / 已提供

公司名義競投： 本人是 (姓名和職位)

授權書及身份證明文件 (如適用)： 現附上 在佳士得記錄上 / 已提供

客戶編號

客戶名稱

商業登記編號

客戶地址 室 樓層

大廈 / 屋苑

街道

城市 / 區 郵區編號

縣 / 省 / 州 國家

客戶名稱及地址會列印在附有是次登記之競投牌編號的發票上；付款資料於拍賣會完結後將不能更改，請確定以上資料確實無誤

國家及地區代碼 電話號碼 電郵地址

B 身份證明文件及財務證明

如閣下未曾於佳士得競投或託售拍賣品，請提供以下文件之副本。個人：政府發出附有相片的身份證明文件 (如國民身份證或護照)，及 (如身份證明文件未有顯示現時住址) 現時住址證明，如公用事業帳單或銀行月結單。公司客戶：公司註冊證書、公司地址證明、被授權競投者附有相片的身份證明文件，由公司董事或法人按公司規定簽署及 (若有) 蓋有公司章的競投授權書，以及列出所有董事及股東的公司文件。其他業務結構，如信託結構、離岸公司或合夥公司：請與信用部聯絡，以諮詢閣下須提供何種資料。電話為：+852 2978 6870。如閣下登記代表未曾於佳士得競投或託售拍賣品人士競投，請附上閣下本人的身份證明文件，以及閣下所代表競投人士的身份證明文件，連同該人士簽署的授權書。新客戶、過去十二個月內未有在佳士得投得拍賣品，及本次擬出價金額高於過往之客戶，須提供銀行信用證明及 / 或近期的銀行月結單，亦或須繳付本公司指定的有關保證金作為允許閣下競投的先決條件。如閣下被要求提供保證金，閣下需與我們聯繫以安排付款。閣下的競投申請會在我們收到保證金的全額付款後方可作實。

高額拍賣品競投牌登記：

閣下是否需要高標拍賣品競投號碼牌？ 是 否

如閣下有意競投 (i) 佳士得亞洲二十世紀及當代藝術晚間拍賣，先鋒薈萃之任何拍賣品；或 (ii) 其他類別拍賣品估價為港幣 8,000,000 元或以上的拍賣品，必須預先登記領取高標拍賣品競投號碼牌。對於高標拍賣品拍賣官只會接受持有高標拍賣品競投號碼牌的競投者出價。閣下需繳付保證金以領取高標拍賣品競投號碼牌。保證金一般為 (i) 港幣 1,000,000 元；或 (ii) 閣下擬競投的全部拍賣品低估價總額之 20%；或 (iii) 其他我們不時設定的金額 (以較高者為準)。閣下可以佳士得接受之信用卡、電匯、本票或支票繳付保證金。請注意佳士得概不接受第三方或代理人代付之款項。即使閣下已於佳士得其他拍賣登記，閣下仍需為高標拍賣品按高標拍賣品登記程序進行登記。請於拍賣舉行前至少 48 小時辦理登記，以確保有充足時間處理閣下的高標拍賣品登記手續。佳士得保留不時更改高標拍賣品登記程序及要求的權利而不作另行通知。

請提供閣下之競投總額：

- 港幣 0 - 500,000 港幣 500,001 - 2,000,000 港幣 2,000,001 - 4,000,000
- 港幣 4,000,001 - 8,000,000 港幣 8,000,001 - 20,000,000 港幣 20,000,000 +

C 拍賣項目登記

本人有意競投下列拍賣項目：

- | | |
|---|--|
| <input type="checkbox"/> 12576 佳士得名釀 | <input type="checkbox"/> 12578 精緻名錶 |
| <input type="checkbox"/> 12577 佳士得名釀 | <input type="checkbox"/> 12561 中國古代書畫 |
| <input type="checkbox"/> 14617 先鋒薈萃 | <input type="checkbox"/> 12562 中國近現代畫 |
| <input type="checkbox"/> 12520 亞洲二十世紀及當代藝術 (晚間拍賣) | <input type="checkbox"/> 12579 瑰麗珠寶及翡翠首飾 |
| <input type="checkbox"/> 12521 亞洲當代藝術 (日間拍賣) | <input type="checkbox"/> 12675 養德堂珍藏中國古陶瓷器 |
| <input type="checkbox"/> 12523 亞洲二十世紀藝術 (日間拍賣) | <input type="checkbox"/> 12587 典雅傳承：手袋及配件 |
| <input type="checkbox"/> 12560 中國當代水墨 | <input type="checkbox"/> 12563 重要中國瓷器及工藝精品 |

D 提貨及運送安排

請選擇下列提貨及運送安排：

- 本人將親自提取已繳付之拍賣品。
- 請按本人之客戶地址 / 以下地址提供貨運報價。

E 聲明

- 本人已細閱載於目錄內之業務規定，買家須知、重要通告及目錄編列方法之說明及不接受第三方付款通告，並同意遵守所有規定。
- 本人已細閱載於目錄內業務規定之資料搜集條款，並同意遵守該規定。
- 拍賣官僅接受已於拍賣日前繳付保證金並已完成高標拍賣品預先登記人士之高標拍賣品競投。本人如悉若本人未於拍賣前完成高標拍賣預先登記，本人將不獲准競投高標拍賣品。
- 若閣下未能成功競投任何拍賣品，對佳士得或佳士得公司集團亦無任何欠款，保證金將以電匯方式或佳士得決定之其他方式退還閣下。請確保閣下已提供有關之銀行資料詳情。
- 如閣下為新客戶並希望透過電郵接收本公司將舉行的拍賣、活動或其他由佳士得集團及其聯營公司提供的服務資料，請於方格內劃上「✓」號。閣下可隨時選擇拒收此訊息。
- 如閣下選擇不以電郵方式收取發票，請於方格內劃上「✓」號。

姓名 簽署 日期

佳士得香港有限公司

香港中環遮打道 18 號歷山大廈 22 樓 電話：+852 2760 1766

www.christies.com



CHRISTIE'S

CHRISTIE'S INTERNATIONAL PLC

Patricia Barbizet, Chairwoman and CEO
Jussi Pylkkänen, Global President
Stephen Brooks, Deputy CEO
Loïc Brivezac, Gilles Erulin, Gilles Pagniez,
Héloïse Temple-Boyer
Sophie Carter, Company Secretary

CHRISTIE'S EXECUTIVE

Patricia Barbizet, Chairwoman and CEO
Jussi Pylkkänen, Global President
Stephen Brooks, Deputy CEO

INTERNATIONAL CHAIRMEN

François Curiel, Chairman, Asia Pacific
Stephen Lash, Chairman, Emeritus, Americas
Viscount Linley, Honorary Chairman, EMERI
Charles Cator, Deputy Chairman, Christie's Int.
Xin Li, Deputy Chairwoman, Christie's Int.

CHRISTIE'S ASIA PACIFIC

François Curiel, Chairman
Xin Li, Deputy Chairwoman

CHRISTIE'S ASIA

Rebecca Wei, President
Jinqing Cai, Chairwoman, China
Jonathan Stone, Chairman, Asian Art

CHAIRMAN'S OFFICE

Eric Chang, Deputy Chairman
Ben Kong, Deputy Chairman
Vickie Sek, Deputy Chairwoman

SENIOR VICE PRESIDENTS

Pola Antebi, Karen Au Yeung, Lavina Chan,
Salene Chan, YF Cheung, Elaine Holt,
Kitty Mak, Ada Ong, Julien Pradel,
Audrey Shum, Simon Tam, Chi Fan Tsang

VICE PRESIDENTS

Hye-Kyung Bae, Chie Banta, Joyce Chan,
Janet Chang, Blanca Cheng, Charmie Hamami,
Gloria Ho, Julia Hu, Pansy Ku,
Marcello Kwan, Elaine Kwok, Mary Lee,
Stephenie Leung, Ruben Lien, Gabrielle Mak,
Lillian Ng, Jasmin Ngai, Patricia Nobel,
Gen Ogo, Jessie Or, Terence Poon,
Bo Tan, Francis Tsang, Tim Triptree,
Lihua Tung, Nicole Wright, Alan Yip,
Kim Yu

ASSOCIATE VICE PRESIDENTS

Hami Bianchi, Carmen Shek Cerne, Jess Chang,
Lesley Chen, Liang-Lin Chen, Amy Cheng,
Shiu-Fung Chiang, Isaac Choi, Terry Choi,
Dai Dai, Aubrey Daval, Phybie Ho,
Dexter How, Yunah Jung, Bigol Lam,
Keyvn Leung, Danqing Li, Nelly Li,
Rachel Li, May Lim, Meng Hong Lim,
Georgina Liu, Sara Mao, Mami Nagase,
Yaovane Nirandara, Benson Or, Felix Pei,
Punchalee Phenjati, Alexandra Reid, Mandy Wang,
Stella Wang, Michael Xie, Jessica Wu,
Wendy Xu, Austin Zhang, Dina Zhang,
Michelle Zhang, Grace Zhuang

CHRISTIE'S ASIA ADVISORY COUNCIL

Rebecca Wei, Chairwoman
Raymond CH'ien, Pierre Chen,
The Baroness Dunn, William Fung,
Joyce Kan, Anthony Lin,
Dee Poon, Mimi Tang,
Robert Tsao, Douglas Woo

CHRISTIE'S CHINA ADVISORY COUNCIL

Jinqing Cai, Chairwoman
Qionger Jiang, Pan Gong Kai, Handel Lee,
Mary Ma, Patrick Thomas, Wang Wei

06/10/16

HONG KONG AUCTION CALENDAR

FINE AND RARE WINES: A GENTLEMAN'S COLLECTION

Sale number: 12576
FRIDAY 25 NOVEMBER
5.00 PM
SATURDAY 26 NOVEMBER
10.30 AM

FINE AND RARE WINES FEATURING EXCEPTIONAL PRIVATE COLLECTIONS

Sale number: 12577
SATURDAY 26 NOVEMBER
1.00 PM

THE PIONEERS

Sale number: 14617
SATURDAY 26 NOVEMBER
6.30 PM
Viewing: 24-26 November

ASIAN 20TH CENTURY & CONTEMPORARY ART (EVENING SALE)

Sale number: 12520
SATURDAY 26 NOVEMBER
7.00 PM
Viewing: 24-26 November

ASIAN CONTEMPORARY ART (DAY SALE)

Sale number: 12521
SUNDAY 27 NOVEMBER
10.30 AM
Viewing: 24-26 November

ASIAN 20TH CENTURY ART (DAY SALE)

Sale number: 12523
SUNDAY 27 NOVEMBER
1.30 PM
Viewing: 24-26 November

CHINESE CONTEMPORARY INK

Sale number: 12560
MONDAY 28 NOVEMBER
11.00 AM
Viewing: 24-27 November

IMPORTANT WATCHES

Sale number: 12578
MONDAY 28 NOVEMBER
12.00 PM
Viewing: 24-27 November

FINE CHINESE CLASSICAL PAINTINGS AND CALLIGRAPHY

Sale number: 12561
MONDAY 28 NOVEMBER
2.30 PM
Viewing: 24-28 November

FINE CHINESE MODERN PAINTINGS

Sale number: 12562
TUESDAY 29 NOVEMBER
10.00 AM & 2.30 PM
Viewing: 24-28 November

HONG KONG MAGNIFICENT JEWELS

Sale number: 12579
TUESDAY 29 NOVEMBER
1.00 PM
Viewing: 24-29 November

CHINESE CERAMICS FROM THE YANGDETANG COLLECTION

Sale number: 12675
WEDNESDAY 30 NOVEMBER
10.30 AM
Viewing: 24-29 November

HANDBAGS & ACCESSORIES

Sale number: 12587
WEDNESDAY 30 NOVEMBER
11.00 AM
Viewing: 24-29 November

IMPORTANT CHINESE CERAMICS AND WORKS OF ART

Sale number: 12563
WEDNESDAY 30 NOVEMBER
11.30 AM & 2.30 PM
Viewing: 24-29 November





CHRISTIE'S 佳士得

22ND FLOOR ALEXANDRA HOUSE 18 CHATER ROAD CENTRAL HONG KONG
香港 中環 遮打道18號 歷山大廈22樓